



## AIRE-VOLVE INTERNAL EXTRACT FANS



## AIRE-VOLVE SINGLE EXTRACT FANS

FEATURES & BENEFITS - ENSURES BEST PRACTICE DESIGN



NEW - AIRE-VOLVE RANGE



COMPACT - IDEAL FOR CEILING VOIDS



MATCHED SILENCERS

### FEATURES & BENEFITS

#### LATEST EC MOTOR TECHNOLOGY

Guarantees longer life and lower SFPs.

#### DOUBLE WALLED PANEL WITH 35MM ACOUSTIC LINING

Ensures lowest breakout.

#### BUILT IN ECOSMART CONTROL

Energy efficient demand control ventilation solution with 80% controllability allowing the duty to be adjusted if ductwork installation changes during construction on site.

#### CONSTANT PRESSURE OPTION

Improves the energy performance of the overall building and guarantees lower energy costs for end users.

#### CLASS L2 LEAKAGE

Units are tested to meet Class L2 leakage. (BS EN 1886 : 2007).

#### FULLY ENCLOSED FAN SPIGOT

Fan and matching silencer system reduces breakout and guarantees a superior acoustic solution.

#### MOST COMPACT 'SIZE FOR DUTY' CASE AVAILABLE ON THE MARKET

Ideal for applications with restricted ceiling voids.

#### FLEXIBLE ACCESS

Range offers either top or bottom access as standard.

Aire-Volve blowers are compliant to EC/327/2011.

#### REMOVABLE UNIT END PANEL

Can be attached to matched silencers prior to connection to ducting system.

#### WIDE DIRECT DUTY RANGE

Available up to 1.9m<sup>3</sup>/s.

#### MANUFACTURED FROM CORROSION RESISTANT HEAVY GAUGE ALUZINC

Has 5 times longer life than galvanised steel and provides higher wear resistance.

#### FULL ACCESSORY RANGE

Includes matched silencers, optional rectangular end panel and dampers.

#### 5 YEAR WARRANTY

Peace of mind.

## ENERGY SAVING ECOSMART CONTROLS

THE MOST FLEXIBLE ENERGY SAVING VENTILATION CONTROL SYSTEM ON THE MARKET WITH FULL BMS INTERFACE



### BENEFITS

#### SIMPLE TO INSTALL

All controls are pre-assembled, configured and installed directly into the fan or air handling unit, this includes 3-port motorised valves and actuators, pipework, off coil thermostats and sensors, frost protection, etc. Site time kept to a minimum, quality and efficiency maintained.

#### SIMPLER SYSTEMS

No need for main VCD, no wasted energy or noise generation because the air volume can be precisely set via the integrated speed control, minimum and maximum speeds easily adjusted via Ecosmart commissioning panel.

#### SIMPLE, PRECISE COMMISSIONING

As recommended in Part L, Ecosmart enables the system to be accurately commissioned via an integrated speed control, minimum and maximum speeds easily adjusted via commissioning panel integral to the control.

#### QUIETER SYSTEMS

With Ecosmart your system is only at maximum design duty when absolutely necessary. The noise levels within your systems are lower because the fans or air handling units are rarely at full speed.

#### PLUG IN CONTROLS

Simple low voltage sensors complete with pre-plugged cable means that any control function is easily achieved. You decide which conditions to monitor and the system will operate at the optimum speed.

#### BMS INTERFACE

Integrated BMS features enable any central system to control and monitor the fan or air handling unit via 0-10V signal. This enables full speed control and heating or cooling enable if installed and volt free status indication as standard.

#### PEACE OF MIND

Ecosmart has a 5 year warranty.

For further details contact Nuaire.



## ECOSMART CONTROLS & ANCILLARIES

STYLISH AND SIMPLE TO OPERATE USER CONTROL  
FACILITATES WITH MANUAL OPERATION WHERE DESIRED

Simple SELV wired, plug-in 'enablers' start and stop the fan, when activated from either start-up or trickle ventilation mode. These 'enablers' include time clocks, infra-red detectors, switch live contacts, humidistats, thermostats and BMS contacts. All systems must include at least one enabler. (NB. When used, BMS control and time clocks take over all other enablers). Integrated speed control (inverter or electronic) is included with all Ecosmart controlled fans and air handlers. ES-ISC are external to some fans and need to be hard wired eg. SQF, Airmover. Once the fan is activated the sensor takes over. They will maintain comfort/design conditions by automatically adjusting fan speed up and down and power or flows through elements or heating/cooling coils. The sensors include temperature, relative humidity, CO<sub>2</sub> or as determined by the BMS.



**BMS**  
0-10V dc signal to activate the system and modulate fan speed. Select/Deselect H&C. Note: this will override any other devices (eg. ES-UCF) fitted (except in Constant Pressure fans).

### ECOSMART ENABLERS & DETECTORS



**ES-PIR2 (PASSIVE INFRA-RED)**  
Detects movement and activates system. Incorporates a system status LED, overrun timer and timer adjustment.



**ES-LCD**  
Touch screen user control in white incorporating time clock facility. This can control the function of the fan by manual setting or using a set of timed programs.



**ES-LCDM**  
Touch screen user control in metal incorporating time clock facility. This can control the function of the fan by manual setting or using a set of timed programs.



**ES-HUMIDISTAT2**  
Activates the system when the RH level is above set point. Incorporates two system status LEDs (Green = OK, Red = Failure) and RH set point level adjustment.



**ES-THERMOSTAT2**  
Activates the system when the temperature is above set point. Incorporates two system status LEDs (Green = OK, Red = Failure) and temperature set point level adjustment.



**ES-AVIZ**  
When fan failure occurs the AVI will flash a warning. Supplied with pre-plugged 10m length of communication cable.



**ES-CO2RM / ES-CO2RMPP**  
Surface mounted room carbon dioxide (CO<sub>2</sub>) sensors which incorporate a temperature sensor. RM = SELV option, RMPP complete with SELV AC powers supply.



**ES-HTCSIG**  
Signal conditioning circuit for humidity, temperature and CO<sub>2</sub> sensors.

### ECOSMART SPEED CONTROLLING SENSORS



**ES-TEMP2 TEMPERATURE SENSOR**  
Modulate fan speed based on room temperature. Incorporates two system status LEDs (Green = OK, Red = Failure) and temperature set point level adjustment.



**ES-RH2 RELATIVE HUMIDITY SENSOR**  
Modulate fan speed based on RH level. Incorporates two system status LEDs (Green = OK, Red = Failure) and RH set point level adjustment.



**ES-UCF MANUAL USER CONTROL**  
Manual 'on' and 'off' system user/speed control. Incorporates two system status LEDs (Green = OK, Red = Failure).



**ES-CI SEMI-AUTOMATIC USER CONTROL**  
Fan, heating & cooling selected by external volt free switch, speed selected by 0-10V signal.



**ES-JB JUNCTION BOX**  
Designed to be compatible with Ecosmart System this unit is supplied with a pre-plugged 10 metre length of communications cable and has 8 further ports.

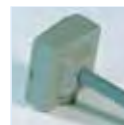

**ES-CO2 SENSOR**  
Duct mounted sensor to modulate fan speed based on CO<sub>2</sub> levels. Connect to fan directly. Pre-wired with 2m cable (not adjustable).



**SWITCHED LIVE BY OTHERS**  
Any mains voltage signal connected to the switched live terminal (S/L) in the unit. This affects the connected fan only.

### SIMPLE PLUG-IN SYSTEM



## AIRE-VOLVE SINGLE EXTRACT FANS

### TECHNICAL INFORMATION

#### PERFORMANCE - AIRE-VOLVE INTERNAL SINGLE EXTRACT FANS 1-9

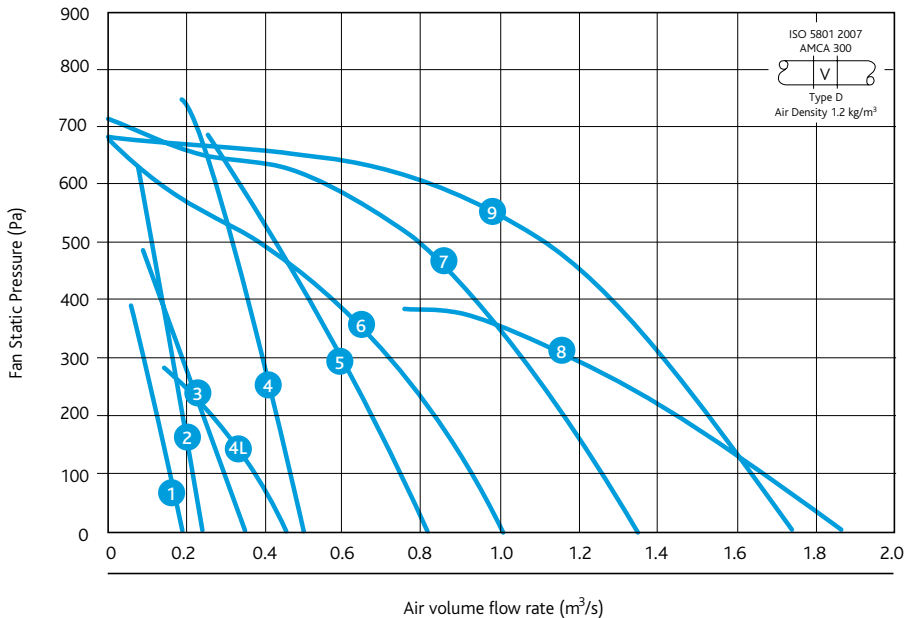

#### Casing



AVS Internal In-line Single Fans

#### Code descriptions

### AVS1



1. Aire-Volve range
2. Single Fan
3. Case size 1-9

#### PERFORMANCE - AIRE-VOLVE INDOOR SINGLE EXTRACT FANS 1-9

#### ELECTRICAL & SOUND

1. Unweighted induct inlet octave band Sound Power level - dB re 1pW
2. Unweighted induct outlet octave band Sound Power level - dB re 1pW
3. Casing radiated octave band Sound Power level - dB re 1pW

Curve/ Code	Duct conn.	Supply (V/Freq Hz/Phase)	FLC (amps)	SC (amps)	Input Power (Max) (W)	Fan Speed (Nominal)	Frequency (Hz)								*Casing Radiated Free Field dBA @ 3m (Spherical Radiation)	
							63	125	250	500	1K	2K	4K	8K		
AVS1	200	230/50/1	0.75	0.75	85	3300	1	73	69	63	63	60	56	52	50	20
							2	75	71	63	63	63	59	53	51	
							3	61	53	43	34	25	21	23	17	
AVS2	200	230/50/1	1.4	1.4	170	4000	1	79	75	69	69	66	62	58	56	26
							2	81	77	69	69	69	65	59	57	
							3	67	59	49	40	31	27	29	23	
AVS3	250	230/50/1	1.35	1.35	170	2500	1	78	74	79	67	63	59	53	51	31
							2	82	77	79	74	69	68	58	58	
							3	68	59	59	45	31	30	28	24	
AVS4	315	230/50/1	3.1	3.1	500	3400	1	84	80	81	83	78	75	71	67	36
							2	87	84	80	84	84	81	75	68	
							3	73	66	60	55	46	43	45	34	
AVS4L	315	230/50/1	1.1	1.1	160	1700	1	72	67	67	66	60	57	53	48	29
							2	74	69	69	70	69	62	58	52	
							3	66	57	55	45	37	30	32	22	
AVS5	315	230/50/1	3.5	3.5	550	2400	1	74	71	69	68	62	61	57	52	25
							2	76	73	71	72	71	66	62	56	
							3	62	55	51	43	33	28	32	22	
AVS6	400	230/50/1	2.9	2.9	450	1700	1	77	80	74	72	66	65	61	54	30
							2	80	82	74	73	67	66	63	56	
							3	66	64	54	44	29	28	33	22	
AVS7	400	230/50/1	3.5	3.5	790	1700	1	78	76	73	73	67	65	62	57	29
							2	81	77	74	75	74	71	67	61	
							3	67	59	54	46	36	33	37	27	
AVS8	500	230/50/1	3.2	3.2	710	1100	1	74	76	71	66	62	64	60	54	27
							2	76	78	73	71	71	69	64	57	
							3	62	60	53	42	33	31	34	23	
AVS9	500	400/50/3	1.85	1.85	1000	1500	1	79	77	76	73	66	66	66	58	32
							2	81	78	79	78	76	72	70	61	
							3	67	60	59	49	38	34	40	27	

\*Break out fan only: These figures are available at 1m dBA, please contact Nuair.

## DIMENSIONS - AIRE-VOLVE INTERNAL SINGLE EXTRACT FANS 1-9

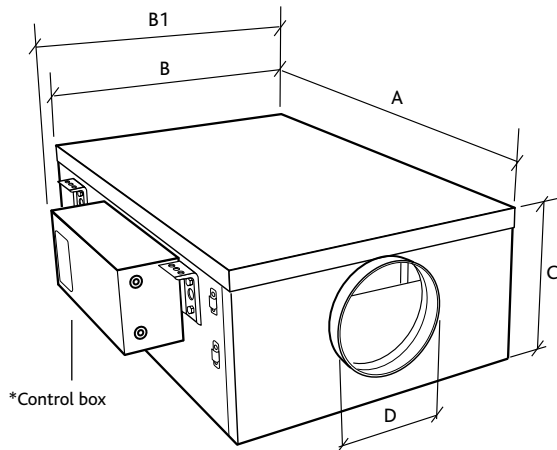

## MATCHED SILENCERS

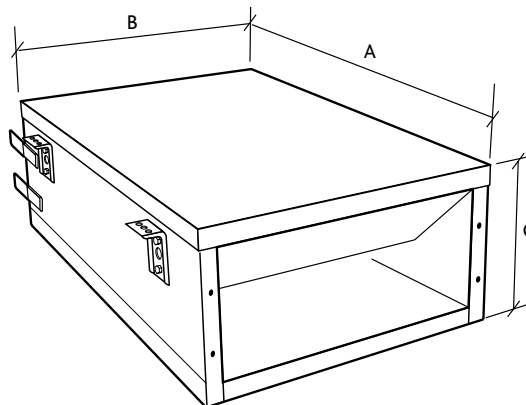

### AVS1-9 DIMENSIONS (mm)

Fan Code	Dim A	Dim A + Spigot Length (inc.85mm)	Dim B	Dim B1 +Control (inc.108mm)	Dim C	Spigot D (dia)	Weight (Kg)
AVS1	580	665	535	NA*	246	200	27
AVS2	615	700	535	643	281	200	24
AVS3	745	830	672	780	329	250	43
AVS4	788	873	672	780	373	315	47
AVS4L	914	999	818	926	391	315	67
AVS5	914	999	818	926	428	315	66
AVS6	1087	1172	911	1019	541	400	90
AVS7	1180	1265	1008	1116	571	400	106
AVS8	1338	1423	1233	1341	611	500	157
AVS9	1338	1423	1233	1341	611	500	141

Bottom access on sizes AVS1-9 as standard. Unit sizes 7-9 have a split bottom access panel. \*Note: AVS1 control is supplied separately to mount remotely.

### SOUND FOR INDIVIDUAL SILENCERS

1. Unweighted induct inlet octave band sound power level - dB re 1pw
2. Unweighted induct outlet octave band sound power level - dB re 1pw
3. Casing radiated octave band sound power level - dB re 1pw

	Frequency (Hz)							
	63	125	250	500	1k	2k	4k	8k
AVS1-MSS	3	8	12	20	22	18	18	14
AVS1-MSL	6	8	15	27	29	24	22	17
AVS2-MSS	3	8	12	20	22	18	18	13
AVS2-MSL	6	10	15	25	26	25	22	17
AVS3-MSS	3	8	12	22	22	24	21	15
AVS3-MSL	6	10	17	27	29	27	23	19
AVS4-MSS	4	4	11	21	18	18	17	17
AVS4-MSL	5	7	17	27	25	24	22	20
AVS4L-MSS	4	4	11	21	18	18	17	17
AVS4L-MSL	5	7	17	27	25	24	22	20
AVS5-MSS	5	7	11	19	21	17	12	12
AVS5-MSL	5	7	16	26	27	23	22	20
AVS6-MSS	5	6	13	17	21	16	15	11
AVS6-MSL	5	7	17	27	25	21	21	17
AVS7-MSS	4	8	11	19	20	16	14	12
AVS7-MSL	5	7	17	27	25	22	23	17
AVS8-MSS	5	7	13	20	21	15	14	12
AVS8-MSL	5	7	17	27	25	21	22	19
AVS9-MSS	5	7	13	19	21	17	15	13
AVS9-MSL	5	7	17	27	25	22	22	20

### AVS1-9 MATCHED SILENCERS CODES & DIMENSIONS (mm)

Fan Code	Size	Silencer Code	A	B	C	Weight (Kg)
AVS1	Standard	AVS1-MSS	1000	535	250	32
	Long	AVS1-MSL	1500	535	250	46
AVS2	Standard	AVS2-MSS	1000	535	285	32
	Long	AVS2-MSL	1500	535	285	46
AVS3	Standard	AVS3-MSS	1000	672	334	39
	Long	AVS3-MSL	1500	672	334	56
AVS4	Standard	AVS4-MSS	1000	672	376	39
	Long	AVS4-MSL	1500	672	376	56
AVS4L	Standard	AVS4-MSS	1000	822	376	39
	Long	AVS4-MSL	1500	822	376	56
AVS5	Standard	AVS5-MSS	1000	822	433	44
	Long	AVS5-MSL	1500	822	433	65
AVS6	Standard	AVS6-MSS	1000	915	545	64
	Long	AVS6-MSL	1500	915	545	89
AVS7	Standard	AVS7-MSS	1000	1013	575	41
	Long	AVS7-MSL	1500	1013	575	98
AVS8	Standard	AVS8-MSS	1000	1237	615	83
	Long	AVS8-MSL	1500	1237	615	114
AVS9	Standard	AVS9-MSS	1000	1237	615	92
	Long	AVS9-MSL	1500	1237	615	125

For details on system silencers see opposite.  
For 500mm length silencers contact Nuair.

### QUICK SELECTION GUIDE

#### AIRE-VOLVE SINGLE FANS 1-9

Fan Code	AV Mounts	Flexible Connector	Acoustic Flexible Connector	End Panel with Rectangular Spigot (W x H)
AVS1	NAV2	CFC20	ACFXRD200	AVT1-RS (152 x 305)
AVS2	NAV2	CFC20	ACFXRD200	AVT2-RS (152 x 305)
AVS3	NAV2	CFC25	ACFXRD250	AVT3-RS (229 x 457)
AVS4	NAV2	CFC31	ACFXRD315	AVT4-RS (229 x 457)
AVS4L	NAV2	CFC31	ACFXRD315	AVT4-RS (229 x 457)
AVS5	NAV5	CFC40	ACFXRD400	AVT5-RS (229 x 457)
AVS6	NAV3	CFC40	ACFXRD400	AVT6-RS (304 x 762)
AVS7	NAV3	CFC50	ACFXRD500	AVT7-RS (381 x 889)
AVS8	NAV6	CFC50	ACFXRD500	AVT8-RS (381 x 889)
AVS9	NAV6	CFC50	ACFXRD500	AVT9-RS (381 x 889)

For details on system silencer see opposite.  
The vertical support brackets are painted in goosewing grey finish.

## AIRE-VOLVE SILENCER SYSTEMS

### TECHNICAL INFORMATION



#### Code descriptions

### AVS1 - SYS1

1	2	3	4

1. Aire-Volve range
2. Single fan
3. Case size 1-9
4. System 1 = Fan unit & 2 standard silencers  
System 2 = Fan unit & 2 long silencers  
System 3 = Fan unit, 1 long & 1 standard silencer

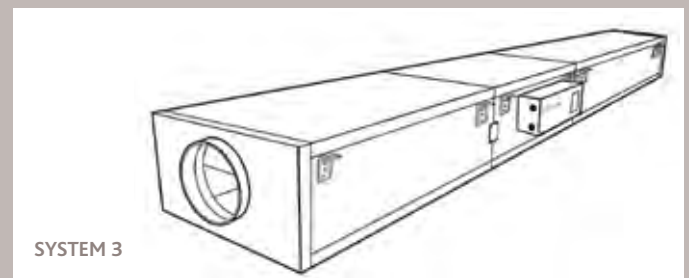
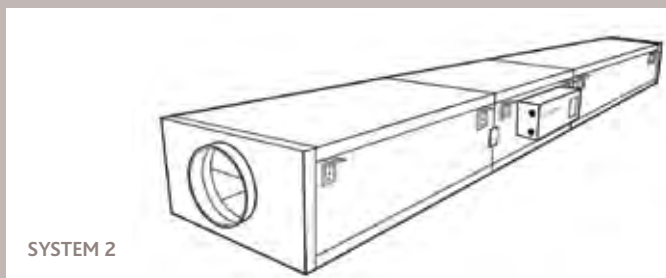
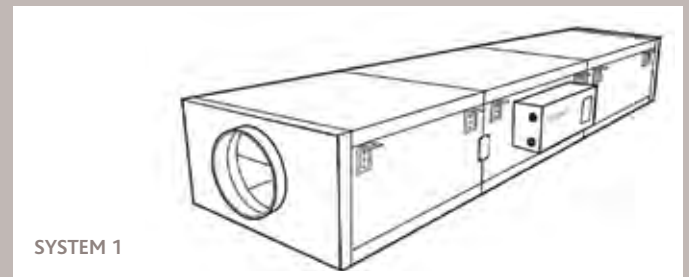
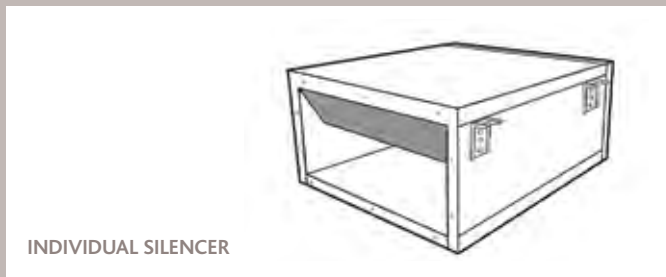

## FEATURES & BENEFITS

#### QUIETEST SYSTEM

Construction is double walled with 35mm acoustic infill.

#### DESIGNED SOLUTION

Matched silencers acoustically designed to work in conjunction with Aire-Volve single fans.

#### COMPLETELY ENCLOSED SPIGOT

Ensures no noise breakout between fan and silencer.

#### LONG LIFE

Aluzinc provides longer life expectancy than other materials and is aesthetically pleasing for exposed sites and roof tops.

#### QUICK & EASY TO INSTALL

Integral mounting brackets allow for attenuators to be easily incorporated into an existing drop rod suspension system.

#### FLEXIBLE SOLUTION

Available in three lengths – 500mm, 1000mm and 1500mm with matching flange. For details on 500mm silencers contact Nuair.

#### 5 YEAR WARRANTY

Peace of mind.

## WIRING - AIRE-VOLVE INTERNAL SINGLE EXTRACT FANS

### Wiring for single phase units AVS1-8.

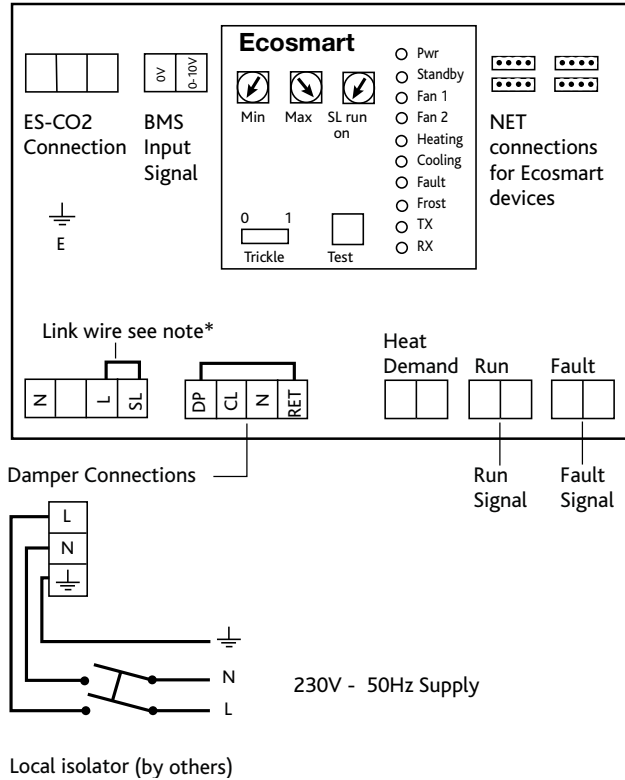

### Wiring for three phase unit AVS9.

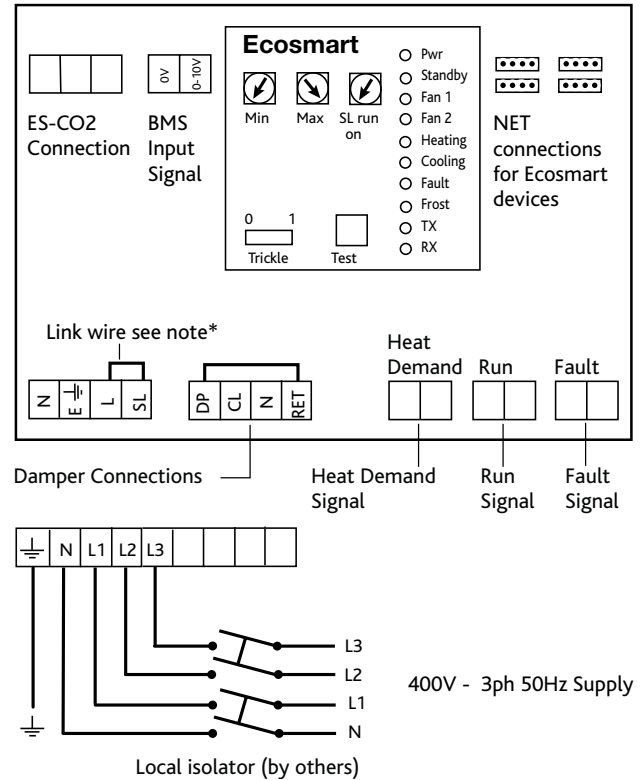

All inter-connections between circuit boards, blowers and sensors are made at the factory.

These diagrams only show the essential field wiring points for clarity.

\*Remove link wire if switched live signal, an enabler or BMS signal is connected.

### Control Module.

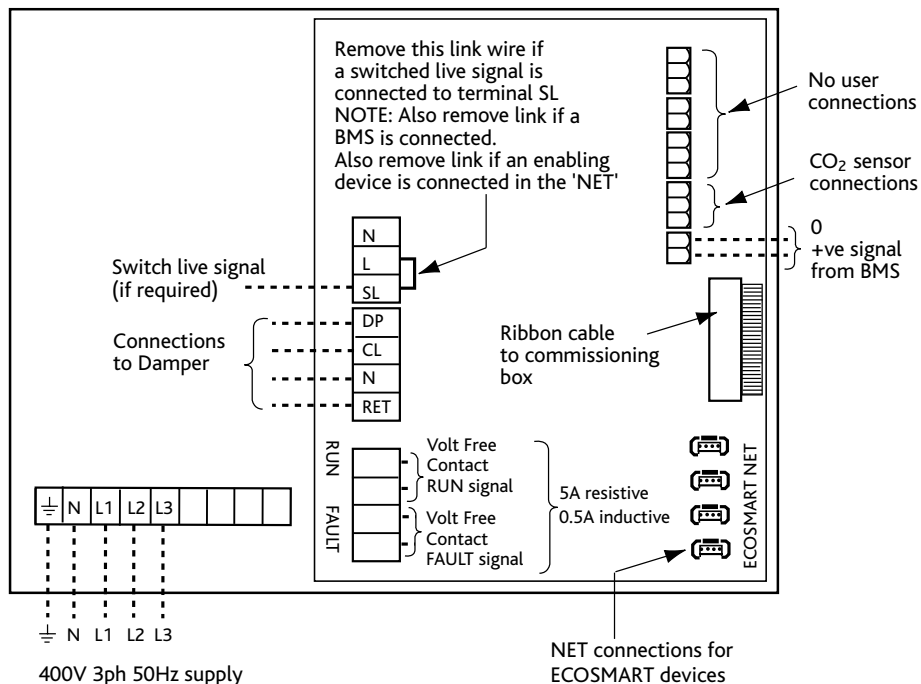



## INTERNALLY MOUNTED AIRE-VOLVE UNIT

### CONSULTANTS SPECIFICATION

#### VENTILATION SYSTEM DESCRIPTION

The extract fan shall be as indicated on the drawings and in accordance with the relevant fan schedule. The stale air shall be extracted from the space using an energy efficient demand ventilation principle; the system shall have its volume flow rate of air varied by a range of low voltage sensors and enablers.

#### FAN DESCRIPTION

The unit shall be double skinned with 35mm infill panels and shall be manufactured from heavy gauge, corrosion resistant Aluzinc steel, internally lined with acoustic material. Fully detachable top or bottom panels for maintenance/service and manometer test points.

EC motors selected to provide the most energy efficient solution conforming to part L regulations. Units shall be direct or belt drive with high efficiency motors as standard, direct drive with EN60034-30 motors fitted with 'hall effect' air flow failure monitoring, units suitable for operation in ambient temperatures of 40°C. The Fan unit shall have a 5 year warranty. The unit and ancillaries shall be of the Aire-Volve type with Ecosmart controls as manufactured by Nuaire Ltd.

#### INSTALLATION REQUIREMENTS

The mechanical contractor shall ensure that all necessary ancillaries are included eg. AV mounts, flexible connections, attenuators, etc. The contractor shall allow for all necessary ductwork transformations to and from the fan unit and any associated components in accordance with the manufacturer's recommendations, DW 144 and general good practice.

#### SYSTEM OPERATION

The extract fan shall automatically vary its speed as it receives signals from one of the interconnected sensors. When the signal is received the fan shall either increase speed gradually until the required level is achieved or it will work on a trickle and boost principle. This will then move the fan duty point from trickle/background ventilation rate to the required boost ventilation rate. Both the trickle and boost rates are infinitely variable, easy to adjust and remove the need of a main balancing damper in accordance with Part L.

#### FAN CONTROL DESCRIPTION

The acoustically lined low noise fan shall be controlled by an integrated Ecosmart control panel mounted to the fan unit\*. The Ecosmart control enables the fan's speed to be varied automatically as conditions in the ventilated space change by linking low voltage sensors or as the low voltage user control is adjusted. It also enables multiple fans to be directly interlinked.

The fans shall have the following energy saving and operational functions integrally installed within it, all components will be pre-wired and fitted by the manufacturer:

- Integral frequency inverter/speed controller
  - Integral adjustable run-on timer
  - Maximum and minimum speed adjustment/ setting (trickle and boost)
  - Volt free run & failure/status indication
  - 0-10V BMS interface for remote operation
  - Low voltage interface with second fan or supply fan
  - Multiple low voltage sockets for interconnection of sensors or fans
  - Background ventilation/trickle enable switch.
- Fan, Ecosmart controls and associated sensors/ controllers shall be manufactured by Nuaire Ltd.

\*AVS1 fan unit has a control supplied loose for remote mounting.

Nuaire's blowers are compliant to EC/327/2011.

#### INSTALLATION

By the appointed contractor. The Aire-Volve fan can be mounted in any orientation. To mount vertically, specifically designed brackets are available from Nuaire. Mechanical installation requires mounting of the extract unit in the designated position and connection to the associated duct work. Top or bottom access is available. Electrical installation requires the provision and connection of single or three phase electrical supply at the fan. The user control (ES-LCD) and low voltage sensor are supplied complete with a 10m length of low voltage, pre-plugged cable.

#### COMMISSIONING

By the appointed qualified commissioning engineer in accordance with CIBSE commissioning Code A: Air Distribution Systems. The systems should be commissioned in the way described in the aforementioned document and the minimum and maximum speed adjustment with the Ecosmart control panel should be set to provide the required ventilation rates. These should be adjusted until the required air volume flow rate is achieved on the approved measuring device. The manufacturer's recommendations should be observed at all times.



## Precise ventilation. The only multi-room ventilation system to provide local 'on demand' control.

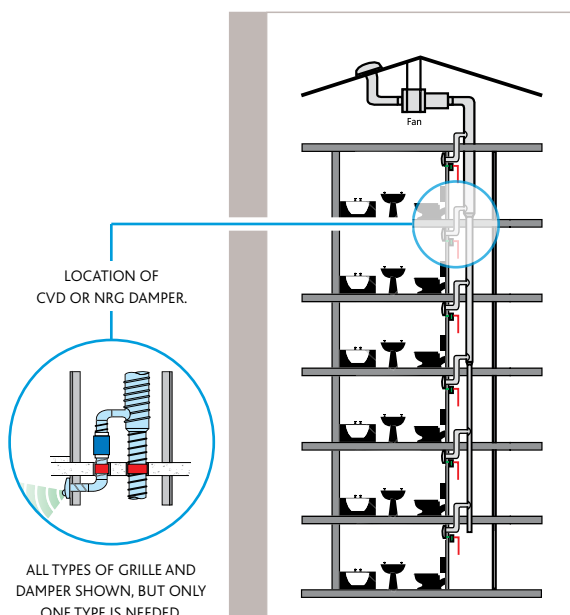

### QUIET OPERATION

Does not generate noise by throttling back on balancing dampers required in conventional systems.

### DUCT MOUNTED CVD DAMPERS

For unobtrusive flexibility.

### SAVES ENERGY

Up to 70% saving over conventionally controlled central systems. Doesn't needlessly extract conditioned air. Fan speed/motor power is dictated by demand requirement.

### UNIQUE DIRECT ACTING MULTI-POSITIONED DAMPER NRG GRILLE

Ensures operation only when room is occupied with integrated PIR2.

### MATCHED DOUBLE WALLED SILENCERS

Aluzinc silencers with 35mm acoustic in fill provides the quietest solution.

### PRE-WIRED

All components are assembled, wired and tested at Nuaire facility, simple 'plug and go'.

**Nuaire. For the complete ventilation solution.**

## AIRE-VOLVE CONSTANT PRESSURE TECHNICAL INFORMATION

### PERFORMANCE - AIRE-VOLVE INTERNAL SINGLE EXTRACT FANS

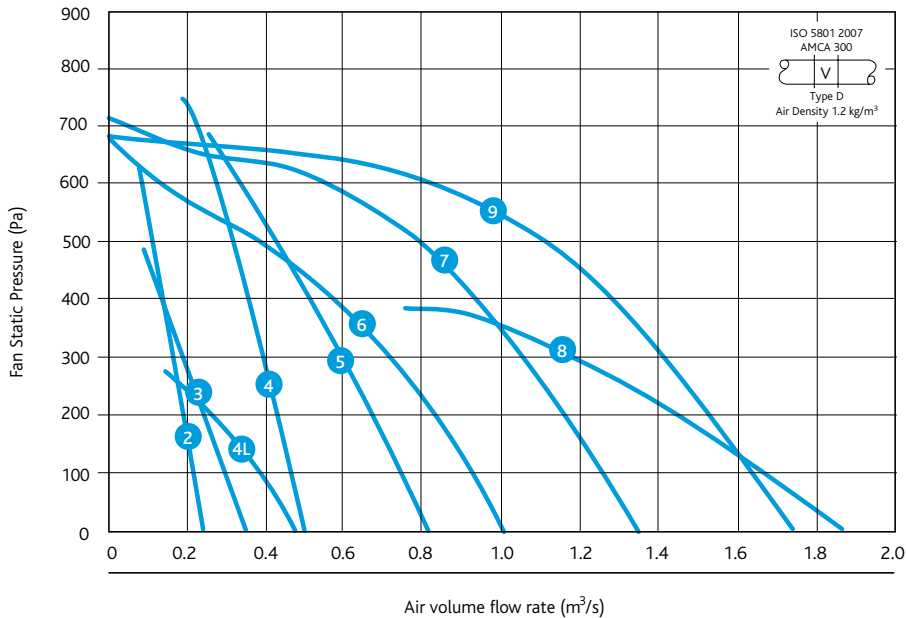

### Casing

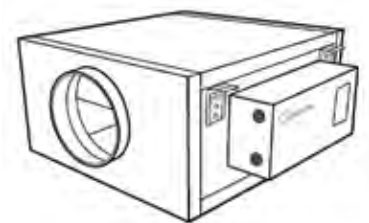

AVSCP2-9 Internal In-line  
Single Extract Fans.

### Code descriptions

## AVSCP2

1 2 3 4

1. Aire-Volve range
2. Single fan
3. Constant pressure control options
4. Case size 2-9

### PERFORMANCE -AIRE-VOLVE INDOOR CONSTANT PRESSURE SINGLE FANS AVSCP2-9

#### ELECTRICAL & SOUND

1. Unweighted induct inlet octave band Sound Power level - dB re 1pW
2. Unweighted induct outlet octave band Sound Power level - dB re 1pW
3. Casing radiated octave band Sound Power level - dB re 1pW

Curve/ Code	Duct conn.	Supply (V/Freq Hz/Phase)	FLC (amps)	SC (amps)	Input Power (Max) (W)	Fan Speed (Nominal)	Frequency (Hz)								*Casing Radiated Free Field dBA @ 3m (Spherical Radiation)
							63	125	250	500	1K	2K	4K	8K	
AVSCP2	200	230/50/1	1.4	1.4	170	4000	1	79	75	69	69	66	62	58	56
							2	81	77	69	69	69	65	59	57
							3	67	59	49	40	31	27	29	23
AVSCP3	250	230/50/1	1.35	1.35	170	2500	1	78	74	79	67	63	59	53	51
							2	82	77	79	74	69	68	58	58
							3	68	59	59	45	31	30	28	24
AVSCP4	315	230/50/1	3.1	3.1	500	3400	1	84	80	81	83	78	75	71	67
							2	87	84	80	84	84	81	75	68
							3	73	66	60	55	46	43	45	34
AVSCP4L	315	230/50/1	1.1	1.1	160	1700	1	72	67	67	66	60	57	53	48
							2	74	69	69	70	69	62	58	52
							3	66	57	55	45	37	30	32	22
AVSCP5	315	230/50/1	3.5	3.5	550	2400	1	74	71	69	68	62	61	57	52
							2	76	73	71	72	71	66	62	56
							3	62	55	51	43	33	28	32	22
AVSCP6	400	230/50/1	2.9	2.9	450	1700	1	77	80	74	72	66	65	61	54
							2	80	82	74	73	67	66	63	56
							3	66	64	54	44	29	28	33	22
AVSCP7	400	230/50/1	3.5	3.5	790	1700	1	78	76	73	73	67	65	62	57
							2	81	77	74	75	74	71	67	61
							3	67	59	54	46	36	33	37	27
AVSCP8	500	230/50/1	3.2	3.2	710	1100	1	74	76	71	66	62	64	60	54
							2	76	78	73	71	71	69	64	57
							3	62	60	53	42	33	31	34	23
AVSCP9	500	400/50/3	1.85	1.85	1000	1500	1	79	77	76	73	66	66	66	58
							2	81	78	79	78	76	72	70	61
							3	67	60	59	49	38	34	40	27

\*Break out fan only: These figures are available at 1m dBA, please contact Nuair. For dimensions and weights refer to page 6.

## WIRING - AIRE-VOLVE INTERNAL SINGLE EXTRACT CONSTANT PRESSURE FANS

### Wiring for single phase units AVSCP1-9.

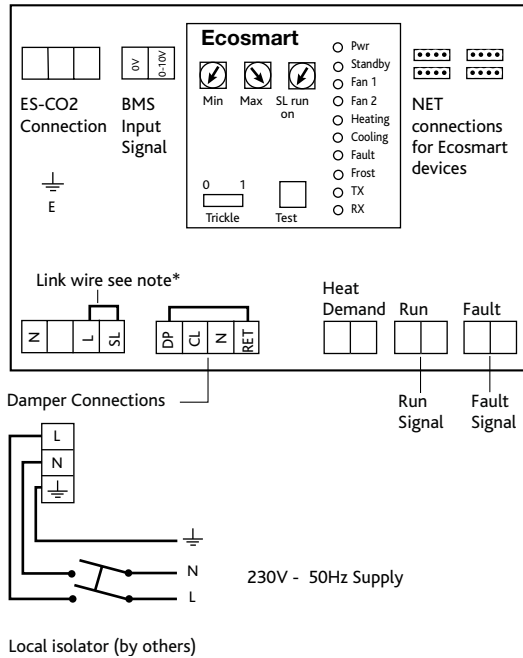

### Wiring for three phase unit AVSCP9.

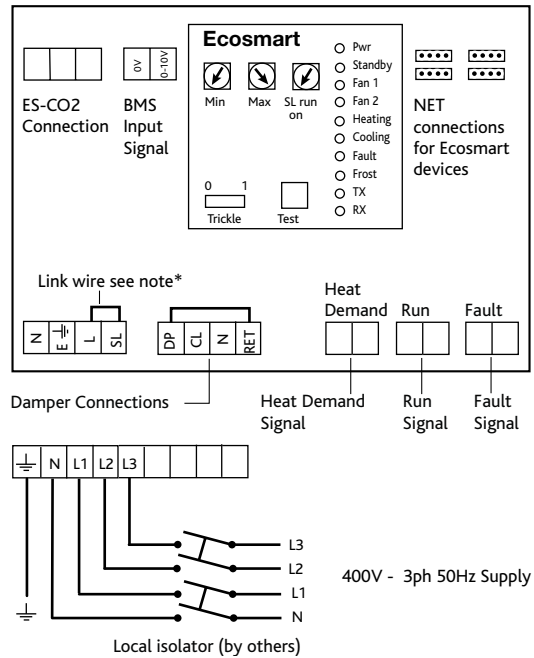

### Control Module.

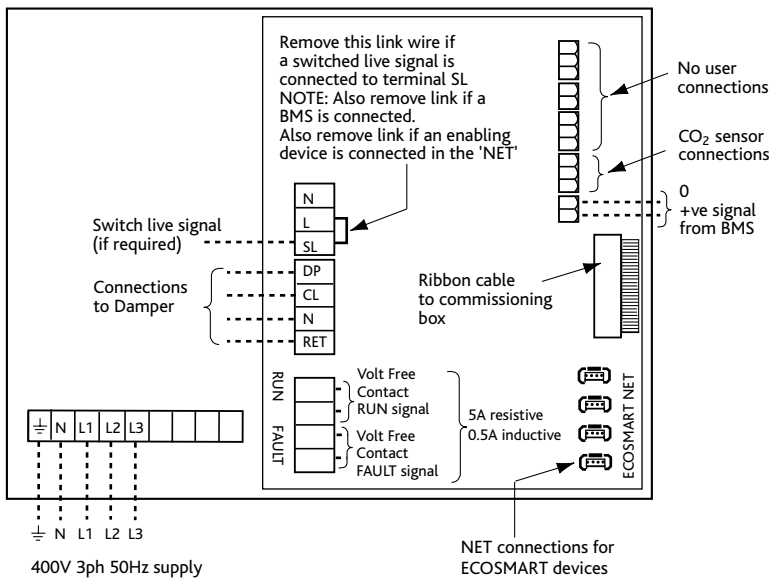

All inter-connections between circuit boards, blowers and sensors are made at the factory. These diagrams only show the essential field wiring points for clarity.

\*Remove link wire if switched live signal, an enabler or BMS signal is connected.

### AVSCP Constant pressure range- Controlling static pressure at fan inlet.

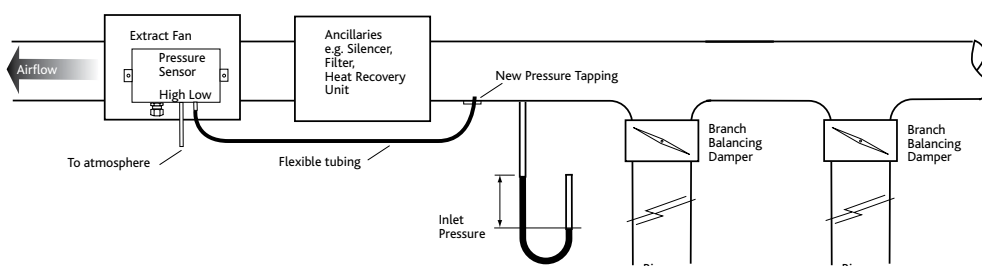

Ecosmart constant pressure extract fans are supplied to control the static pressure at the fan inlet. This set up is suitable for the majority of applications. However, when ancillaries with high pressure losses are fitted to the fan's inlet side, the low pressure tapping needs to be moved from the fan chamber to a location upstream of the ancillaries as shown below in diagram. Failure to do this will result in excessive pressure being applied to the dampers at the rooms when the system is running in trickle mode.

## INTERNALLY MOUNTED AIRE-VOLVE UNIT WITH CONSTANT PRESSURE

### CONSULTANTS SPECIFICATION

#### VENTILATION SYSTEM DESCRIPTION

The extract fan shall be as indicated on the drawings and in accordance with the relevant fan schedule. The vitiated air shall be extracted from the space using an energy efficient constant pressure principle via a variable air volume motorised damper/grille installed in each area, as detailed in the schedule.

#### SYSTEM OPERATION

The extract fan shall automatically vary its speed as the system pressure varies; the variation in pressure is caused by the opening and closing of the Nuaire inline CVD or surface mounted NRG damper. The damper is autonomous of the fan and requires no field wiring connecting it to the fan. The damper positions are open (boost) and closed (trickle). The inline damper has an integrated airflow sensor which continuously monitors and controls the amount of air being moved. (The air volume is adjusted via minimum and maximum potentiometers on the side of the CVD damper and a run on timer). The damper/grille shall be as manufactured by Nuaire Ltd.

The duct mounted damper CVD requires a 230V connection/power supply. Signal from 230V switch live ie. light switch, PIR, humidistat etc. (If the NRG grille is installed it shall be connected to a 12V ac supply via the inclusive 230V transformer unit and has an integral PIR, two position damper and overrun timer). Once commissioned and set to work, the fan will maintain the preset pressure by varying its speed as the ventilation requirement within each area varies ie. as dampers open and close. If the requirement exceeds the maximum or minimum limit, the fan will remain at the design/limiting speed.

#### FAN CONTROL DESCRIPTION

The acoustically lined low noise fan shall be controlled by an integrated Ecosmart control panel mounted\* adjacent to the fan unit. The Ecosmart control enables the fan's speed to be varied automatically as conditions in the ventilated space change by linking low voltage sensors or as the low voltage user control is adjusted. It also enables multiple fans to be directly interlinked.

The fans shall have the following energy saving and operational functions integrally installed within it, all components will be pre-wired and fitted by the manufacturer:

- Integral frequency inverter/speed controller
  - Integral adjustable run-on timer
  - Maximum and minimum speed adjustment/setting (trickle and boost)
  - Volt free run & failure/status indication
  - 0-10V BMS interface for remote operation
  - Low voltage interface with second fan or supply fan
  - Multiple low voltage sockets for interconnection of sensors or fans
  - Background ventilation/trickle enable switch.
- Fan, Ecosmart controls and associated sensors/controllers shall be manufactured by Nuaire Ltd.

#### CVD FEATURES

- Trickle/boost flow rate.
- Run on timer.
- Externally adjusted settings.
- CVD acts as a balancing damper.
- MEMS (air flow sensor) provide precise measurements and control of flow rate.

The Fan unit shall have a 5 year warranty, first year parts and labour the remainder parts only.

\*AVSCP1-ES unit has a control supplied loose for remote mounting and size 1 is not available with Constant Pressure.

#### INSTALLATION

By the appointed contractor. The Aire-Volve fan can be mounted in any orientation. To mount vertically, specifically designed brackets are available from Nuaire. Mechanical installation requires mounting of the extract unit in the designated position and connection to the associated duct work. Top or bottom access is available for quick and easy installation and maintenance. Electrical installation requires the provision and connection of single or three phase electrical supply at the fan. The user control and low voltage sensor are supplied complete with a 10m length of low voltage, pre-plugged cable.

#### COMMISSIONING

By the appointed qualified commissioning engineer in accordance with CIBSE commissioning Code A: Air Distribution Systems.

The systems should be commissioned in the way described in the aforementioned document and the minimum and maximum speed adjustment with the Ecosmart control panel should be set to provide the required ventilation rates. These should be adjusted until the required air volume flow rate is achieved on the approved measuring device. NOTE: NRG & CVD should not be mixed on same system. The manufacturer's recommendations must be observed at all times.

## THE COMPLETE VENTILATION SOLUTION

WHATEVER YOUR VENTILATION STRATEGY, WE OFFER THE TOTAL VENTILATION SOLUTION

All buildings have their own unique requirements for ventilation. With the new government guidelines on energy efficiency it is more difficult to maintain a comfortable, healthy environment whilst providing an energy efficient solution. Nuair has over 40,000 product lines to select from whatever your requirements, we have the solution from a small extract fan to large air handling units.

### MECHANICAL EXTRACT FOR OFFICES & COMMUNAL AREAS

Extract fans are the simplest form of ventilation for office and communal environments. Whether duct, wall, window or ceiling mounted these fans will extract moisture from wet rooms and offices to provide continuous fresh air.

### STAIRWELL PRESSURISATION & SMOKE EXTRACT FOR MULTI-FLOOR REQUIREMENTS

Nuair have manufactured smoke and car park ventilation for over 30 years including smoke pressurisation and extract fans (duct or roof mounted) for 300/400°C for 1 & 2 hours, certified to EN12101-3 2002.

### CAR PARK EXTRACT

The comprehensive range of AXUS smoke fans together with the Impulse car park fan meets the ever increasing need to provide smoke extract for car parks.

## AIR HANDLING UNITS

### BOXER PACKAGED SOLUTIONS

Heating and cooling up to 6m<sup>3</sup>/s.



## MULTI-ROOM VENTILATION



### CONSTANT PRESSURE VARIABLE VOLUME

Twin fan and single fan - high performance extract up to 2.65m<sup>3</sup>/s.



### UNI-X HEAT RECOVERY

Low depth, high performance to ventilate up to 12 bed cluster.



### XBC PACKAGED HEAT RECOVERY

Low depth, high performance range up to 2m<sup>3</sup>/s.

**AIRE-VOLVE -  
HIGH EFFICIENCY  
CENTRIFUGAL INLINE  
FAN RANGE UP TO 1.9m<sup>3</sup>/s:**



**SMOKE SOLUTIONS**

**MECHANICAL EXTRACT FOR  
OFFICES AND COMMUNAL AREAS**

**CAR PARK EXTRACT OPTIONS**



**IMPULSE HIGH TEMPERATURE EXTRACT**  
Powerful impulse fan certified to EN12101-3  
(300°C for 2 hours).

**STAIRWELL  
PRESSURISATION  
& SMOKE EXTRACT  
APPLICATIONS**



**AXUS SMOKE & AXT**  
High temperature & ambient axial  
extract fans up to 85m<sup>3</sup>/s.

**AIRE-VOLVE**  
Low profile new Twin Fan up  
to 1.9m<sup>3</sup>/s. Low SFP and noise.

**DAVE**  
High performance extract  
(and supply) up to 1.2m<sup>3</sup>/s.

**ES-OPUSDC**  
Energy efficient range of inline,  
surface and recessed fans up  
to 115l/s.

**TERMINATOR**  
Horizontal discharge roof  
extract fan.

**XS RANGE**  
Wall, window, ceiling and roof  
extract fans (up to 530l/s).

**SQUIF RANGE**  
Run and standby units ideal for  
'out of airstream' applications  
such as commercial kitchens.  
Twin fan option.





**FOR MORE INFORMATION**

[www.nuaire.co.uk](http://www.nuaire.co.uk)

**COMMERCIAL**

[www.nuaire.co.uk/commercial](http://www.nuaire.co.uk/commercial)

**RESIDENTIAL**

[www.nuaire.co.uk/residential](http://www.nuaire.co.uk/residential)

**FAN SELECTOR**

[www.nuaire.co.uk/fanselector](http://www.nuaire.co.uk/fanselector)



**NUAIRE**

**Western Industrial Estate | Caerphilly | CF83 1NA**

**t +44 (0)29 2085 8200 | f +44 (0)29 2085 8300 | e [enquiries@nuaire.co.uk](mailto:enquiries@nuaire.co.uk)**

**[www.nuaire.co.uk](http://www.nuaire.co.uk)**

As part of our policy of continuous product development Nuaire reserves the right to alter specifications without prior notice.  
Telephone calls may be recorded for quality and training purposes.

Part No. 671585/Z. March 2018.