

## XBOXER HEAT EXCHANGE UNITS

WIDE RANGE OF ENERGY EFFICIENT  
HEAT RECOVERY UNITS WITH OPTIONAL INTEGRATED CONTROLS.

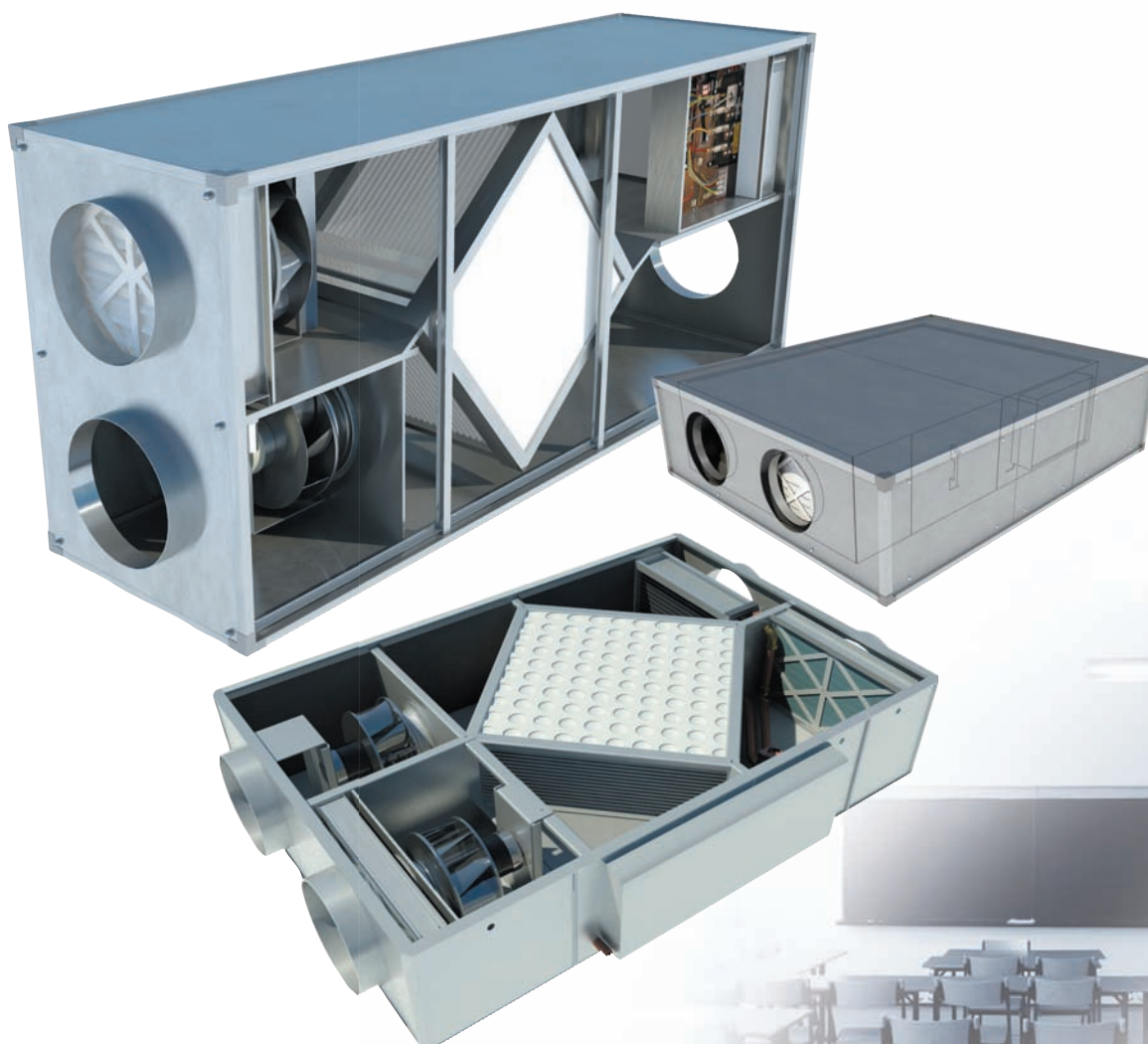

## BENEFITS

### HIGH EFFICIENCY

Heat exchanger efficiency of up to 70%, alongside high efficiency motors and backward curved impellers.

### ENERGY EFFICIENT CONTROLS

Full Ecosmart control compatibility provides a simple 'plug & go' control solution with BMS interface and trickle and boost as standard.

### NO CONTROL OPTION AVAILABLE

Now available on all sizes.

### SPACE SAVING SOLUTIONS

Stacked or horizontal units, provide the most effective solution.

### QUIETEST SOLUTION

Units are double skinned keeping breakout noise to the lowest possible levels.  
Optional acoustic enclosure available.

### WIDE RANGE

Horizontal, stacked and twinfan options available up to 5m<sup>3</sup>/s. Refer to AHU catalogue for full range.

### QUICK COMMISSIONING

Integrated supply and extract fan allows precise system duty can be quickly and accurately set. (Ecosmart models only).

### EASY INSTALLATION

All XB models (sizes 2 - 6) are supplied in one piece.

### EASY MAINTENANCE

Left or right hand options (in direction of airflow) – will provide full access to components. For access requirements contact Nuair.

### INTEGRATED SUMMER BYPASS

Operates automatically via integrated factory set temperature sensors.

### WEATHERPROOF DETAIL

Can be factory or fitted on site, please refer to page 71 for details.

Note: weather proof enclosure for XB2 - XB5 is supplied as a separate component.

### ADVANCED CONDENSATE REMOVAL

Miniature condensate pump option, for applications where the distance to discharge is great. Pump also enables a 'micro bore' type pipe to be used.

### FILTER OPTIONS

G4 fitted as standard. Higher grade integrated filters available. Duct mounted ancillary also available.

### DX COIL OPTION AVAILABLE

Please contact Nuair.

### CONSTANT PRESSURE CONTROL AVAILABLE

For further details please contact Nuair.

### HEATER BATTERY OPTIONS

Unit with integral battery, LPHW or electric.

### ANCILLARIES

A range of ancillaries are available including manometers, bulkhead lights, view ports, drain trays & traps.

For further details please contact Nuair.

### 5 YEAR WARRANTY

On Ecosmart models for peace of mind.  
No control models have a 2 year warranty. Contact Nuair for details.

#### FEATURES INCLUDE:



With electric heater.



With LPHW.



Constant Pressure control option.



Filter option.



Bottom access available (XB2-5).

# AIR HANDLING UNITS (AHU'S)

## XBOXER HEAT EXCHANGE

### TECHNICAL INFORMATION

#### PERFORMANCE - XBOXER HEAT EXCHANGE

XBOXER Horizontal sizes: (XB2-5) and (S1-XB and S6-XB)

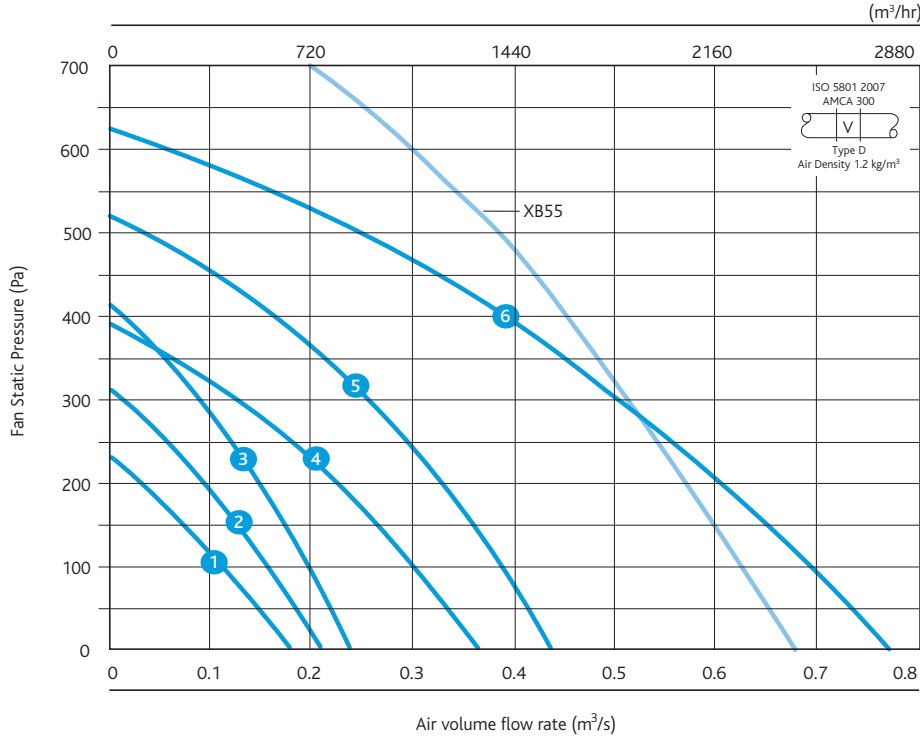

Note: refer to AHU catalogue for XB55 horizontal unit details.

#### Casing

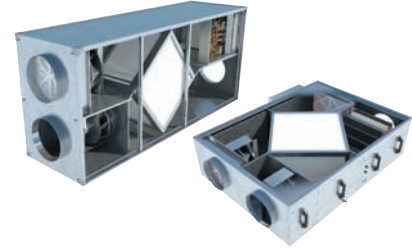

#### Code descriptions

### XB2 - R L 2 AE

1 2 3 4 5 6

1. Xboxer (S1-XB, XB2-5 or S6-XB)
2. Curve ref.
3. Component layout  
L = Left hand  
R = Right hand
4. Type of heater battery fitted  
N = No heater  
L = LPHW  
E = Electric
5. 2 = 2 row coil or 3 = 3 row coil
6. Optional Acoustic Enclosure (sizes XB2 - 5 only)

\*For coil options please see page 73.

#### PERFORMANCE - XBOXER HORIZONTAL XB AND XBH AND STACKED XBV

### ELECTRICAL, SOUND & WEIGHT

Curve Code	Phase	Motor power watts	Start current (amps)	Full load current (amps)	Electric Heater (kW)	Heater FLC (amps)	LPHW Heater (kW)	Induct Sound Power Levels dB re 1pW								Breakout dBA @3m	Weight (Kg)	
								63	125	250	500	1K	2K	4K	8K			
1 S1-XB-**	1	172	1.28	1.28	-	1.28	*	Intake	60	55	54	47	41	37	33	29	33	75
								Supply	64	67	63	59	62	60	57	53		
								Discharge	68	69	64	61	62	60	56	51		
								Extract	61	60	56	48	41	37	32	28		
2 XB2-**	1	270	1.7	1.7	4.5	18.7	*	Intake	71	71	69	66	62	54	52	49	34	153
								Supply	64	64	64	62	57	57	40	28		
								Discharge	67	70	65	69	60	59	56	49		
								Extract	60	62	53	50	47	37	29	25		
3 XB3-**	1	410	1.9	1.9	4.5	18.7	*	Intake	75	75	73	70	66	58	56	53	36	153
								Supply	68	68	68	66	61	61	44	32		
								Discharge	71	74	69	73	64	63	60	53		
								Extract	64	66	57	58	51	41	33	29		
4 XB4-**	1	423	2.8	2.8	4.5	18.7	*	Intake	76	75	71	70	69	60	57	53	36	155
								Supply	64	62	63	61	59	56	46	36		
								Discharge	74	73	70	73	70	68	63	56		
								Extract	67	63	55	57	54	45	37	30		
5 XB5-**	1	690	3.6	3.6	4.5	18.7	*	Intake	80	79	75	74	73	64	61	57	38	155
								Supply	68	66	67	65	63	60	50	40		
								Discharge	78	77	74	77	74	72	67	60		
								Extract	71	67	59	61	58	49	41	34		
6 S6-XB-**	1	850	6	6	6	25	*	Intake	82	86	80	68	67	64	57	51	47	212
								Supply	76	79	76	67	62	59	50	40		
								Discharge	85	86	80	74	72	68	61	54		
								Extract	77	80	73	64	59	55	47	44		

Units are supplied c/w with 2 No.G4 filters as standard. F5 & F7 filters are available as integrated options on supply.

Motor power and current loads are the total for both fans running together. Unit has a soft start function therefore the starting current is identical to the full load.

\*\* Add relevant code for handling and heater type.

\* For details on coils, codes and selection please refer to page 73.

Note: Size 6 - 1 phase = supply for fan, 3 phase = supply for electric heater battery.

**DIMENSIONS AND CONFIGURATIONS**

**XBOXER Horizontal size S1-XB**

**DIMENSIONS (mm)**

Code	A	B	C	D
S1-XB	1361	1000	340	250

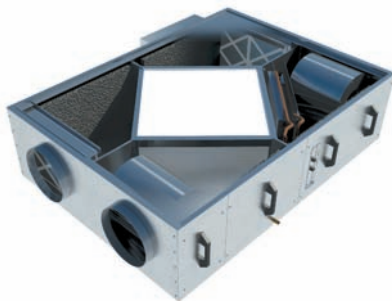
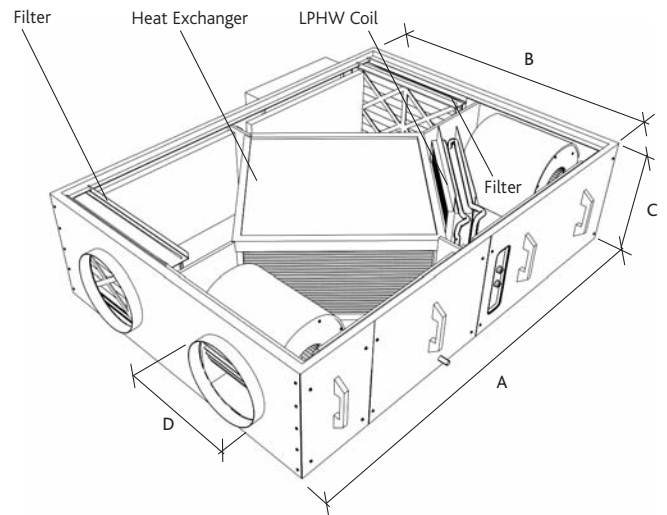

Model shown: S1-XB-LL (left hand with LPHW).

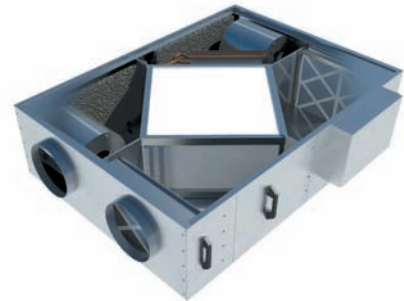

Model shown: S1-XB-RL (right hand with LPHW).

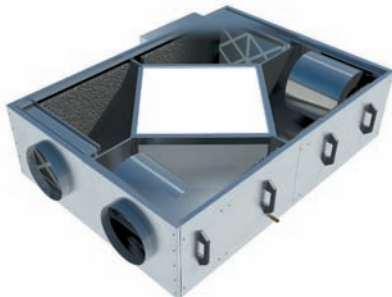

Model shown: S1-XB-LN (left hand with no heater).

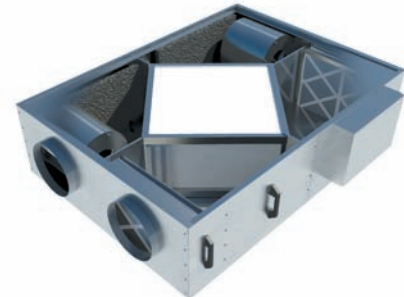

Model shown: S1-XB-RN (right hand with no heater).

## AIR HANDLING UNITS (AHU'S)

### XBOXER HEAT EXCHANGE

#### TECHNICAL INFORMATION

### DIMENSIONS AND CONFIGURATIONS

#### XBOXER Horizontal sizes XB2, 3, 4, 5 and S6-XB

#### DIMENSIONS (mm)

Code	A	B	C	D
XB2	1700	1150	340	315
XB3	1700	1150	340	315
XB4	1700	1150	340	315
XB5	1700	1150	340	315
S6-XB	1700	1150	700	500

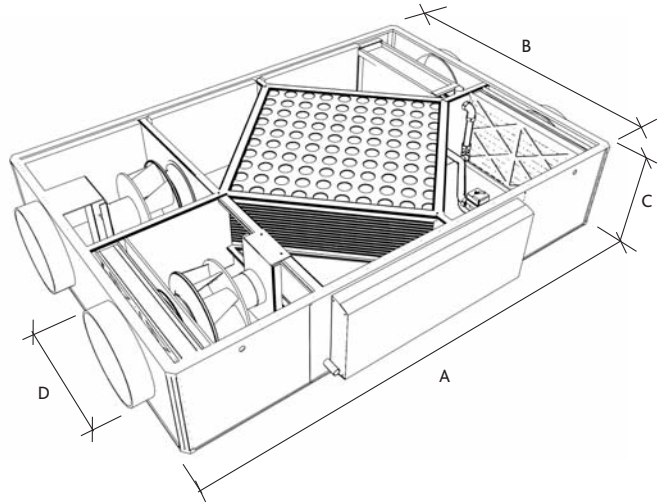

Model shown: XB2-5-LL (left hand with LPHW).

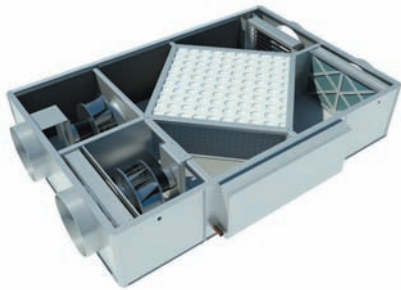

Model shown: XB2-5 and S6-XB-RE (right hand with electric heater).

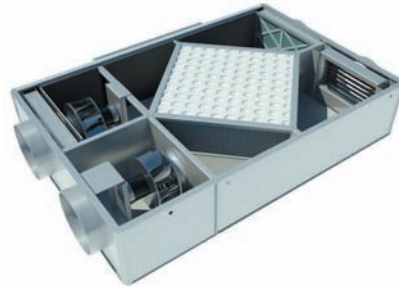

Model shown: XB2-5 and S6-XB-LE (left hand with electric heater).

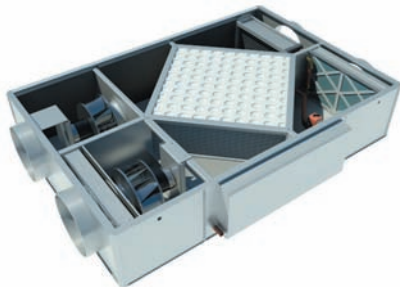

Model shown: XB2-5 and S6-XB-LL (left hand with LPHW).

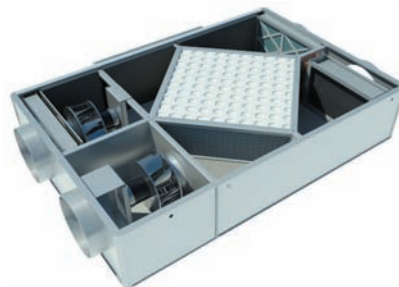

Model shown: XB2-5 and S6-XB-RL (right hand with LPHW).

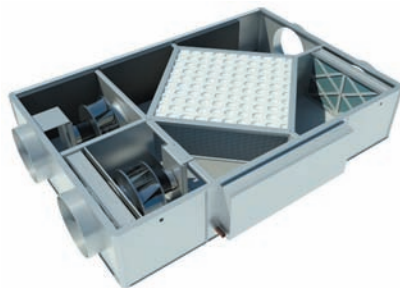

Model shown: XB2-5 and S6-XB-LN (left hand with no heater).

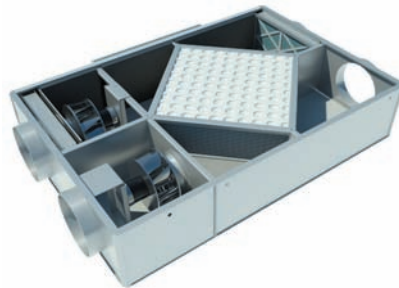

Model shown: XB2-5 and 6-XB-RN (right hand with no heater).

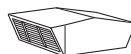

For weatherproof cowls refer to page 71

**WEATHER PROTECTION FOR XBOXER HORIZONTAL UNIT**

Sizes XB2 - 5 and XB6

- Weatherproof construction
- Can be retro fitted on site (Please contact Nuaire)
- Complete with bird/vermin mesh and internal airflow divider
- Available in 2 sizes

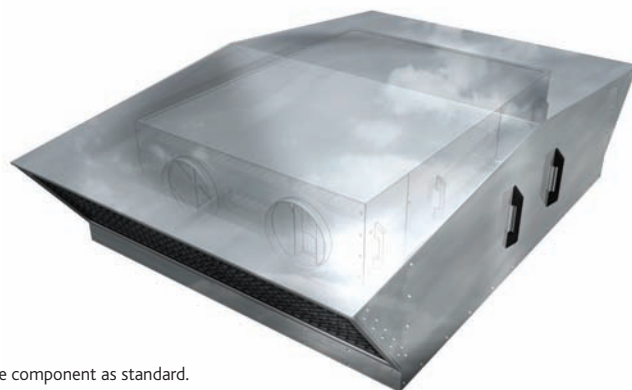

Note: The enclosure above is supplied as a separate component as standard.

**DIMENSIONS (mm)**

View from end

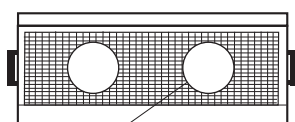

Vermin mesh guard (can be removed and cut for duct access).

View from side

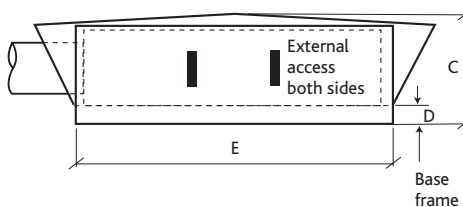

View from top

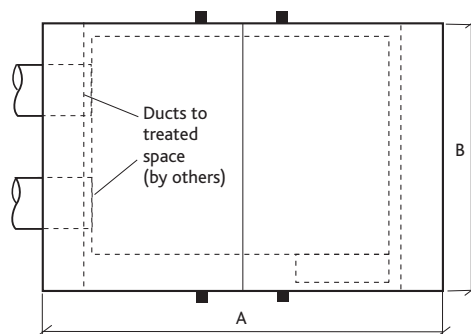

**DIMENSIONS (mm)**

Unit Code	Unit size	A	B	C	D	E	Weight (Kg)
SXB-WP	2 - 5	2400	1400	530	100	1800	65
SXB6-WP	6	2400	1400	880	100	1800	79

Code example for on-site fitting

**SXB - WP**

Code example for factory fitting

**XB2 - LEWP**

ACOUSTIC ENCLOSURE FOR XBOXER HORIZONTAL UNIT

Sizes XB2 - 5

The additional breakout reduction of a standard 25mm double skinned pentapost enclosure (close coupled to the unit inside) is as shown below.

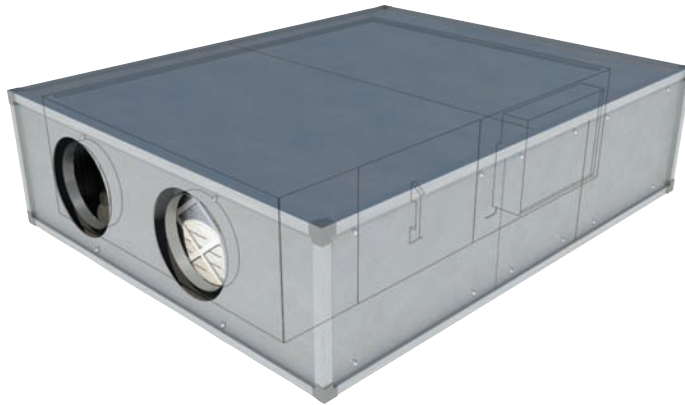

BREAKOUT REDUCTION

	Frequency (Hz)						
	125	250	500	1K	2K	4K	8K
Sound reduction index Db	8	14	21	23	24	23	19

Code example for factory fitting

**XB2 - RL - AE**

It is recommended the Acoustic Enclosure (see code example below) be ordered with the XBOXER unit and fitted at the factory.





## AIR HANDLING UNITS (AHU'S)

### XBOXER HEAT EXCHANGE

#### TECHNICAL INFORMATION

#### HEAT RECOVERY PERFORMANCE

To determine the temperature of the supply air - after the heat exchanger module (but before the heater if fitted), refer to the following table.

When selecting heater batteries, use this temperature as the "Air On" temperature in the coil selection tables.

Heat Exchanger Temperature Ratio (%) ("efficiency")	Intake Air Temperature (deg C) (External)	(ROOM) Extract Air Temperature (deg C)					
		5	10	15	20	25	30
		Supply Air Temperature (deg C)					
55	-5	1	3	6	9	12	14
	0	3	6	8	11	14	17
	5	5	8	11	13	16	19
	10	7	10	13	16	18	21
	15	10	12	15	18	21	23
60	-5	1	4	7	10	13	16
	0	3	6	9	12	15	18
	5	5	8	11	14	17	20
	10	7	10	13	16	19	22
	15	9	12	15	18	21	24
65	-5	2	5	8	11	15	18
	0	3	7	10	13	16	20
	5	5	8	12	15	18	21
	10	7	10	13	17	20	23
	15	9	12	15	18	22	25
70	-5	2	6	9	13	16	20
	0	4	7	11	14	18	21
	5	5	9	12	16	19	23
	10	7	10	14	17	21	24
	15	8	12	15	19	22	26
75	-5	3	6	10	14	18	21
	0	4	8	11	15	19	23
	5	5	9	13	16	20	24
	10	6	10	14	18	21	25
	15	8	11	15	19	23	26
80	-5	3	7	11	15	19	23
	0	4	8	12	16	20	24
	5	5	9	13	17	21	25
	10	6	10	14	18	22	26
	15	7	11	15	19	23	27
85	-5	4	8	12	16	21	25
	0	4	9	13	17	21	26
	5	5	9	14	18	22	26
	10	6	10	14	19	23	27
	15	7	11	15	19	24	28
90	-5	4	9	13	18	22	27
	0	5	9	14	18	23	27
	5	5	10	14	19	23	28
	10	6	10	15	19	24	28
	15	6	11	15	20	24	29

Other conditions may be calculated using the equation:

$$\eta_t = \text{Thermal efficiency} = \frac{t_{\text{supply}} - t_{\text{intake}}}{(t_{\text{extract}} - t_{\text{intake}})}$$

This table and equation assume that the supply and extract mass flow rates are equal.

**Note: for specific fan power ratings contact Nuaire for details.**



**HOW MUCH ENERGY DOES THE EXCHANGER SAVE?**

In a building ventilation system that does not have a heat recovery facility, the air used for ventilation enters the building at the external ambient temperature, and is expelled from the building at approximately room temperature.

This increase in temperature may be caused directly by heaters intended to raise the air temperature to a suitable value for supply to occupied rooms, or indirectly by heat transfer from the buildings internal surfaces and existing air content.

This "ventilation heat loss" can be quantified as:

$$\text{Air Mass Flow rate (kg/s)} \times \text{Air volume flow rate (m}^3\text{/s)} \times \text{Air density (kg/m}^3\text{)} \\ \times \text{Temperature difference (deg C) [T}_a\text{ internal} - \text{T}_a\text{ external]} \\ \times \text{Specific Heat Capacity of air (kJ/kg deg C)}$$

(Approx = 1)

Using some typical (heating season) values, the power required to heat unit air flow, and which is then lost is:

$$= 1\text{m}^3\text{/s} \times 1.2\text{ kg/m}^3 \times (22-6)\text{ deg C} \times 1 \\ = 19.2\text{ kW}$$

Heat recovery systems reduce this heat loss by transferring the heat contained in the extracted air to the supply air.

A system with a heat exchange efficiency of 70% will recover 70% of the energy supplied therefore reducing the power required.

There is of course an energy penalty in terms of the additional pressure loss due to the heat exchanger element itself, and this needs to be minimized by optimal selection of the system fans, motors and control systems. Generally, it can be demonstrated that the additional system losses are small compared to the reduction in heating load.

**ELECTRIC HEATING**

To find the final supply air temperature when an electric heater is required, use the following table:

Air Volume Flow rate m <sup>3</sup> /s	Intake Air Temperature (deg C)	Electric heater kW												
		2	3	6	9	12	15	18	21	24	27	54		
		Supply Air Temperature (deg C)												
0.1	-5	12	20											
	0	17	25											
	5	22	30											
	10	27	35											
	15	32												
0.2	-5		8	20	33									
	0	8	13	25	38									
	5	13	18	30										
	10	18	23	35										
	15	23	28											
0.4	-5			8	14	20	26	33						
	0		6	13	19	25	31	38						
	5	9	11	18	24	30	36							
	10	14	16	23	29	35								
	15	19	21	28	34									
0.6	-5			8	8	12	16	20	24	28	33			
	0			13	13	17	21	25	29	33	38			
	5	8	9	13	18	22	26	30	34	38				
	10	13	14	18	23	27	31	35	39					
	15	18	19	23	28	32	36							
0.8	-5			6	9	13	16	19	22	25	28	33		
	0			11	14	18	21	24	27	30	33	38		
	5	7	8	11	14	18	21	24	27	30	33	38		
	10	12	13	16	19	23	26	29	32	35	38			
	15	17	18	21	24	28	31	34	37					
1	-5			5	8	10	13	15	18	20	23	25	28	40
	0			10	13	15	18	20	23	25	28	30	33	38
	5	7	8	10	13	15	18	20	23	25	28	30	33	38
	10	12	13	15	18	20	23	25	28	30	33	35	38	
	15	17	18	20	23	25	28	30	33	35	38			
1.5	-5			5	7	10	12	13	15	17	18	20	23	30
	0			10	12	15	17	18	20	22	23	25	28	35
	5	6	7	10	12	15	17	18	20	22	23	25	28	40
	10	11	12	13	15	17	18	20	22	23	25	28	30	
	15	16	17	18	20	22	23	25	27	28	30			
2	-5			5	6	10	11	13	14	15	16	18	20	28
	0			10	11	13	14	15	16	18	19	20	21	28
	5	6	6	8	9	10	11	13	14	15	16	18	20	28
	10	11	11	13	14	15	16	18	19	20	21	23	25	33
	15	16	16	18	19	20	21	23	24	25	26	28	30	38
3	-5			5	6	10	11	13	14	15	16	18	20	28
	0			10	11	13	14	15	16	18	19	20	21	28
	5	6	6	7	8	10	11	13	14	15	16	17	18	25
	10	11	11	12	13	13	14	15	16	17	18	19	20	25
	15	16	16	17	18	18	19	20	21	22	23	24	25	30

WIRING FOR XB2-5 & S6-XB-R/L E EXTRACT/SUPPLY

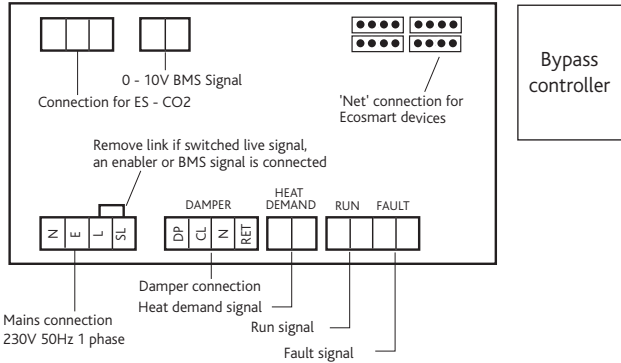

Bypass controller

S1-XB & S6-XB-R/L N EXTRACT/SUPPLY

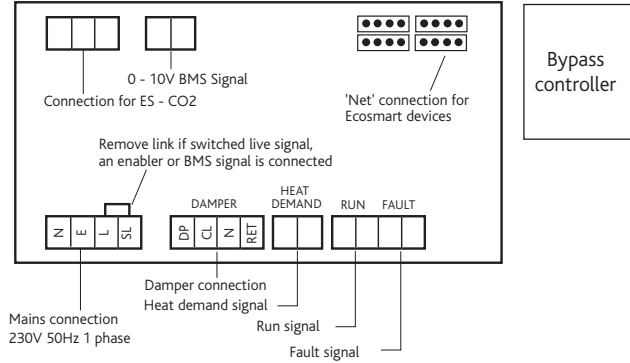

Bypass controller

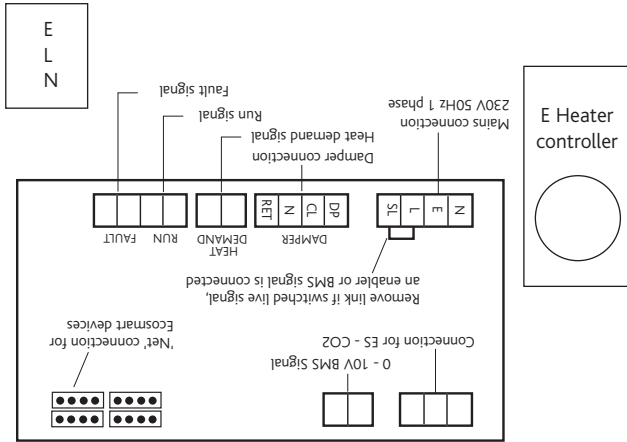

E Heater controller

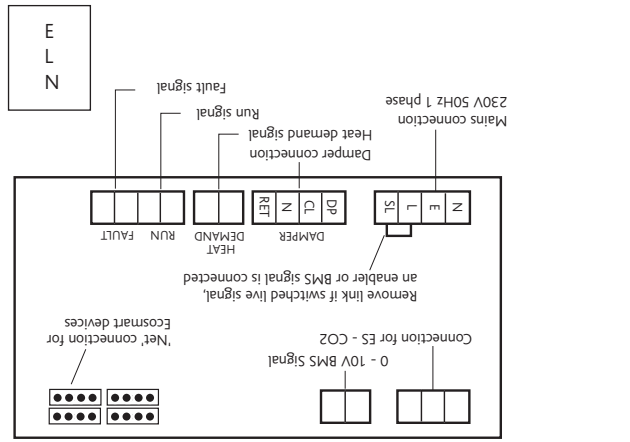

WIRING FOR S1-XB, XB2-5 & S6-XB-R/L L EXTRACT/SUPPLY

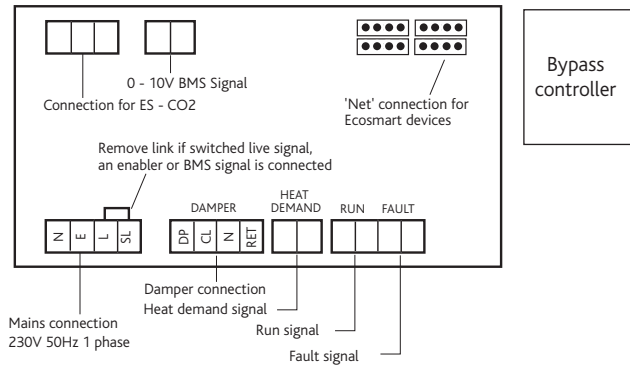

Bypass controller

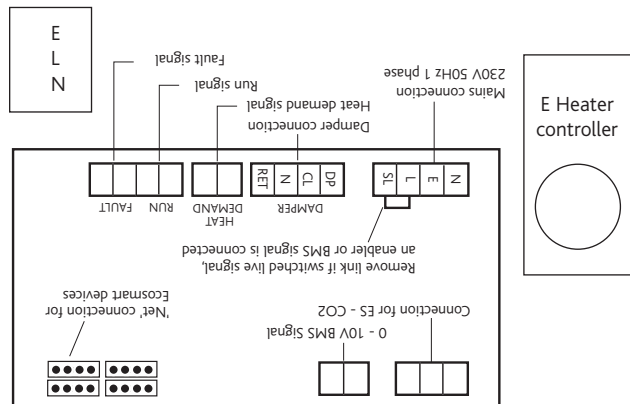

E Heater controller

**XB2-5 WITH ECOSMART FAN ONLY CONTROL**

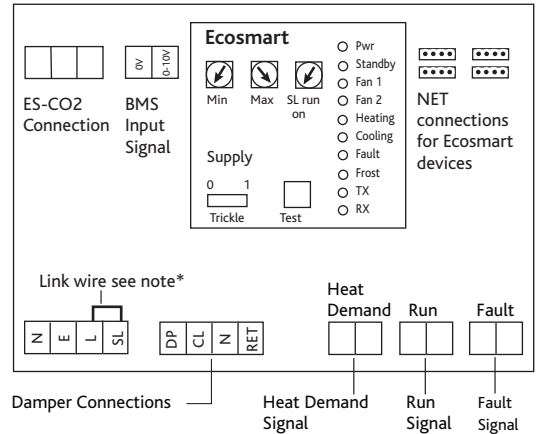
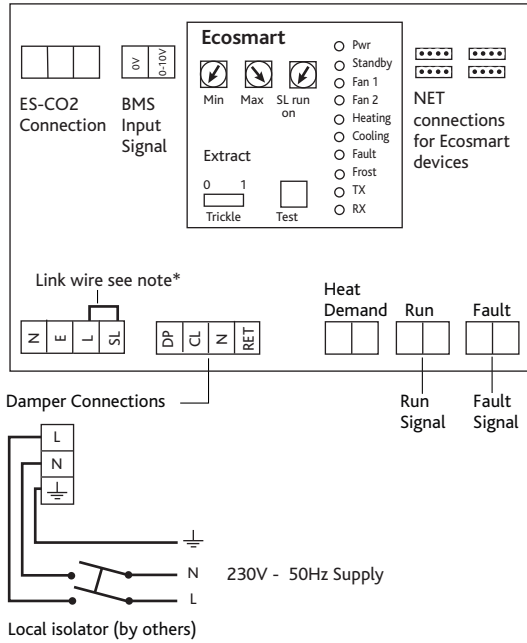

All inter-connections between circuit boards, blowers and sensors are made at the factory. This diagram only shows the essential field wiring points for clarity.

\*Remove link wire if switched live signal, an enabler or BMS signal is connected.

**XB2-5 WITH ECOSMART CONTROL AND ELECTRIC HEATER**

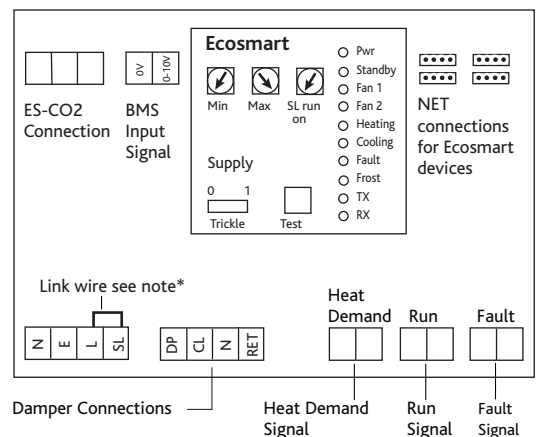
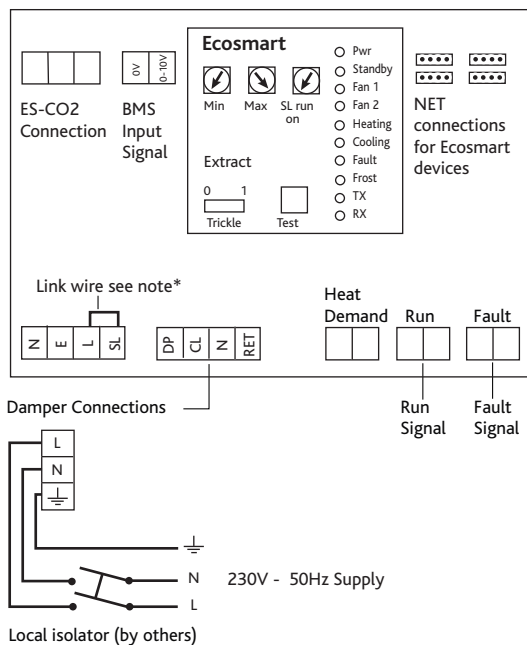

All inter-connections between circuit boards, blowers and sensors are made at the factory. This diagram only shows the essential field wiring points for clarity.

\*Remove link wire if switched live signal, an enabler or BMS signal is connected.

**XB2-5 WITH ECOSMART FAN AND LPHW COIL CONTROL**

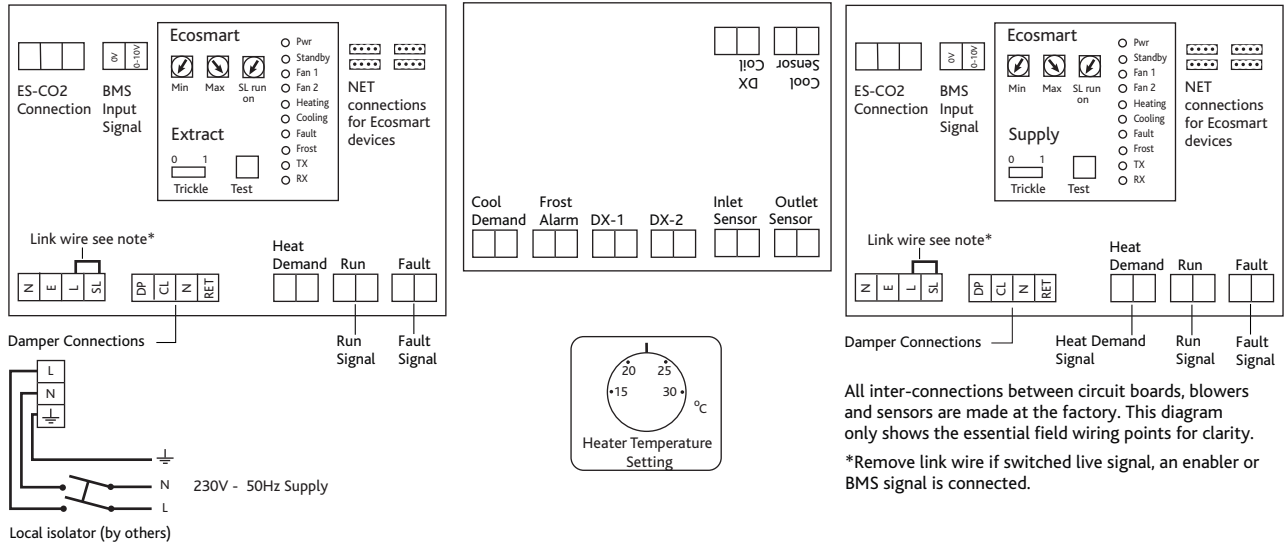

All inter-connections between circuit boards, blowers and sensors are made at the factory. This diagram only shows the essential field wiring points for clarity.  
 \*Remove link wire if switched live signal, an enabler or BMS signal is connected.

**WIRING - FOR UNITS SUPPLIED WITHOUT ECOSMART CONTROL**

The wiring illustrations below are for the fans, bypass damper and electric heater for units without control. All wiring is terminated in junction boxes fitted to the specified side of the unit.

It is the installer's responsibility to select and fit the appropriate control equipment to produce the desired output.

Note that any heating/cooling coils fitted are supplied without control valve and actuator.

**ELECTRICAL DETAILS**

Unit size	Fan motor ratings		Electric heater ratings (if fitted)	
	flc	sc	kW	flc
XB2	2 x 0.75A	2 x 3A	4.5kW	18.7A
XB3	2 x 0.75A	2 x 3A	4.5kW	18.7A
XB4	2 x 1.2A	2 x 4.8A	4.5kW	18.7A
XB5	2 x 1.2A	2 x 4.8A	4.5kW	18.7A

Bypass damper rated at 3W, 13mA for all unit sizes.

(Unit sizes XB2-5) Fan wiring. Two per unit and one per blower.

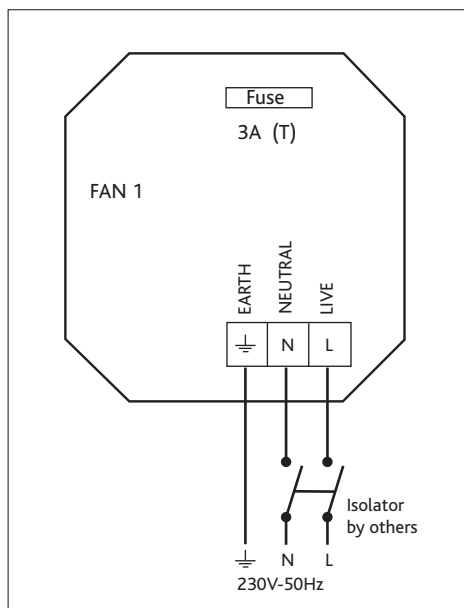

(Unit sizes XB2-5) with electric heater, heat exchanger bypass damper and electric heater wiring.

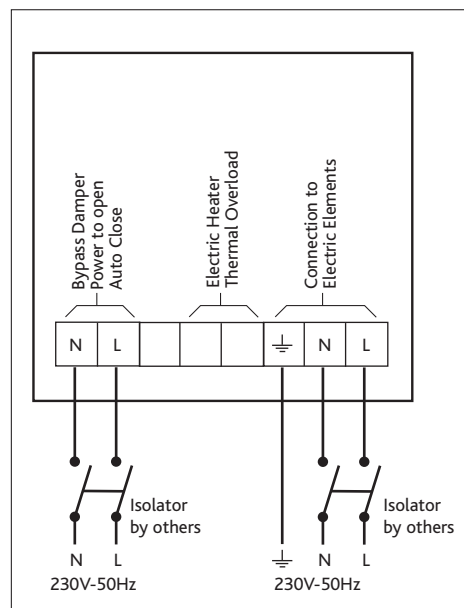

(Unit sizes XB2-5) Fan only or with LPHW coil, heat exchanger bypass damper wiring.

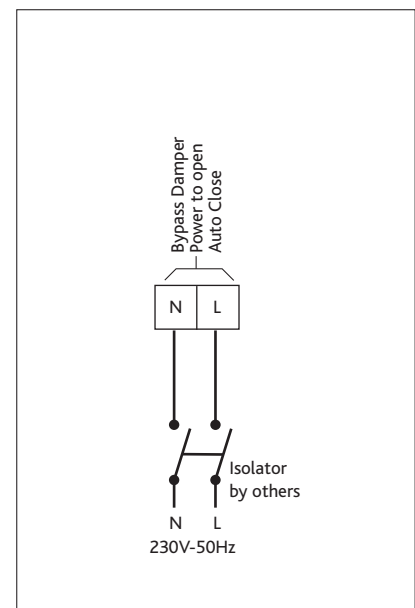

## CONSULTANTS SPECIFICATION

### XBOXER TWINFAN UNITS

#### OPERATION

The supply and extract ventilation unit shall be as indicated on the drawings and shall be in accordance with the particular fan schedule in the specification.

Supply air to the room shall be pre-heated by the extract air via the integrated heat exchanger matrix. Where fitted an integrated heater battery shall raise the temperature of the supply air to the design room temperature after the air has passed through the heat exchanger.

The ventilation unit shall automatically vary the ventilation rate, as it receives signals from one of the optional interconnected sensors. When signals are received, the fan shall either vary its speed proportionally or on a trickle and boost principle. The unit shall have the facility to commission the supply and extract fans individually via inbuilt minimum and maximum speed adjustment, the fans themselves shall have infinitely variable speed control.

#### XBOXER TWINFANS - UNIT SPECIFICATION

Unit codes XB shall be manufactured in aluminium alloy with 25mm double skinned infill panels and extruded aluminium frame. Unit codes XBV and H shall be manufactured from Aluzinc with 25mm infill panels, giving extremely low noise levels. It shall be come c/w a high efficiency heat exchanger block, supply and extract filters, automatic summer bypass, integral minimum and maximum infinitely variable speed controls, run on timer and fascia mounted failure indication. The unit shall have low energy, high efficiency a.c. fan/motor assemblies with sealed for life bearings. Impellers shall be high efficiency mixed flow or centrifugal type.

The unit shall have a robust plastic/aluminium heat exchanger matrix with a thermal efficiency of up to 55 - 70% that shall be protected by G4\* grade pleated filters on supply and extract. It shall come complete with condensate drip tray and 22mm drain connection (XB2-5 has a 15mm drain connection). Alternatively a condensate pump shall be provided if specified.

The unit shall be constructed with removable panels allowing full maintenance access from the side (access handing to be confirmed in product code and verified on site prior to order). The removable panels shall provide access to the following:

- Supply or extract fan.
- Supply & extract filter.
- Heat exchanger block.
- Heater battery temperature adjustment (where included).
- LPHW Heater pipe connections. (where included).
- Speed control commissioning adjustment (min & max).
- Electrical connection terminal blocks.
- Units shall be the as manufactured by Nuair.
- 2 fans incorporate auto change over in the event of one fan failing.

\* Other filter specifications including high capacity filters & grade F7 available as integrated options.

### XBOXER TWINFANS - ECOSMART CONTROLS

All versions shall incorporate the following functions integrally mounted, pre-wired and factory fitted by the manufacturer: -

- Integral infinitely variable speed control on supply and extract.
- Integral background ventilation control/set point.
- Integral boost ventilation control/set point.
- Integral BMS interfaces – summer/winter switching, heating control\*\*, 0-10V speed adjustment.
- Integral run on timer.
- Volt free failure indication (direct from individual fan).
- Integral S/L terminal for boost trigger from remote switch, e.g. lightswitch.
- Integral air off coil temperature adjustment\*\*
- Multiple IDC sockets for interconnection of up to 6 Ecosmart sensors, controllers or fans using pre-plugged 4-core low voltage cable.
- Volt free frost alarm/heat demand interface\*\*
- Frost protection/hold off stat\*\*
- The unit shall be controlled by the ECOSMART control devices (enablers & sensors) as detailed in the schedule on the drawings.
- 2 fans incorporate auto change over in the event of one fan failing.
- LPHW pipework connections c/w diverting valve and actuator.\*\*

\*\* Versions incorporating heater sections.

### INVERTER DRIVES

Sizes 2 - 5 have AC control, size 6 has EC control.

### NO CONTROL OPTION (SIZES 7-10 XBH + XBV)

Unit provides side mounting of termination box to connect supply and extract fan motor wiring (terminal boxes) for interface to custom built control panels. For this option, no sensors are fitted to the unit, but with plate heat exchanger units the bypass damper actuator is included.

### COIL TYPES AND CONTROLS

The control for the coils shall be fully integrated and shall maintain a constant off coil temperature. The system shall have frost protection which shall, at temperatures below 4 degrees C, fully open the 3 or 4-port valve and only start the fan when the temperature at the filter has risen above the designated set point.

### LOW PRESSURE HOT WATER

The Low Pressure Hot Water heating coil shall be factory fitted with a 3 or 4 port valve, drain cocks and air vents. The actuator controlling the 3 or 4 port valve shall be controlled via the on-board PCB by the off coil temperature sensor. All components pre-piped, assembled and tested by the manufacturers.

### ELECTRIC

The Electric Heater Battery shall be factory fitted and pre-wired to an integral closed loop thyristor control. When the unit is switched off, the fan shall continue to run to dissipate heat from the electric heater battery before stopping.

The Ecosmart control unit shall have a 5 year warranty.

The manufacturer's recommendations should be observed at all times.

The unit shall be the XBOXER and shall be manufactured by Nuair.