

Dave Supply DS-NC

DAVE Supply Fans With No Control Installation Manual



1.0 SAFETY INFORMATION

- The provision of the electrical supply and the connection of the unit to the electrical supply must be carried out by a qualified electrician.
- Isolate from power supply before removing any covers. During installation / maintenance ensure all covers are fitted before switching on the mains supply.
- All-pole disconnection from the mains as shown in the wiring diagram must be incorporated within the fixed wiring and shall have a minimum contact separation of 3mm in accordance with latest edition of the wiring regulations.
- This unit must be earthed.
- Ducting must be securely fixed with screws to the spigot to prevent access to live parts. Duct runs terminating close to the fan must be adequately protected by suitable guards.
- This appliance should not be used by children or persons with reduced physical, sensory or mental capabilities or lack of experience and knowledge, unless they have been given supervision or instruction concerning the safe use of the appliance by a person responsible for their safety. Children shall not play with the appliance. Cleaning and user maintenance shall not be carried out by children.

1.1 Symbols



GENERAL WARNING

Signifies a general warning regarding hazard specified by supplementary information.



ELECTRIC SHOCK

This unit must be completely electrically isolated before any panels are removed. Check mains supply and control connections.



ROTATING PARTS

This unit contains fast moving rotational parts which may start automatically. It is the sole responsibility of the installer to adequately guard these components.



REFER TO INSTRUCTION MANUAL

Read and understand the installation and maintenance manual before installing, operating or maintaining this product.

1.2 Important Information

This manual contains important information on the safe and appropriate assembly, transport, commissioning, operation, maintenance, disassembly and simple troubleshooting of the product.

While the product has been manufactured according to the accepted rules of current technology, there is still a danger of personal injury or damage to equipment if the following general safety instructions and the warnings contained in these instructions are not complied with.

- Read these instructions completely and thoroughly before working with the product.
- Keep these instructions in a location where they are accessible to all users at all times.
- Always include the operating instructions when you pass the product on to third parties.

1.3 Personal Protective Equipment

The following minimum Personal Protective Equipment (PPE) is recommended when interacting with Nuair product:

- Protective Steel Toed Shoes - when handling heavy objects.
- Full Finger Gloves (Marigold PU800 or equivalent) - when handling sheet metal components.
- Semi Fingerless Gloves (Marigold PU3000 3DO or equivalent) - when conducting light work on the unit requiring tactile dexterity.
- Safety Glasses - when conducting any cleaning/cutting operation or exchanging filters.
- Reusable Half Mask Respirators - when replacing filters which have been in contact with normal room or environmental air.

Nuair would always recommend a site specific risk assessment by a competent person to determine if any additional PPE is required.

2.0 INTRODUCTION

The Dave range of in-line backward curve fans consists of 9 sizes with a maximum duty of 1.1m³/s (1100l/s).

Units are manufactured from aluzinc, rectangular in section and have circular rigid spigots at each end. All units are supplied with fixing brackets designed to simplify installation.

2.1 Code Description:

1	2	3	-	4	5	6
DS	2	HA	-	L	NC	H

- 1. Range: **DS** = DAVE Supply
- 2. Unit Size: **1 - 7**
- 3. Fan / Case Type: **A** = Extended Case (Includes G3 Filter)
H = High Pressure Fan (Size 2 & 4 only)
HA = High Pressure Fan (Size 2 & 4 only) with Extended Case (Includes G3 Filter)
- 4. Heating Type: **E** = Electric Heating
L = LPHW Heating
N = No Heating
- 5. Control: **NC** = No Control
- 6. Electrical Frequency: **No Reference** = 50Hz
H = 60Hz

3.0 DELIVERY & RECEIPT OF EQUIPMENT

All equipment is inspected prior to despatch and leaves the factory in good condition. Upon receipt of the equipment an inspection should be made and any damage indicated on the delivery note.

Particulars of damage and/or incomplete delivery should be endorsed by the driver delivering the goods before offloading by the purchaser.

No responsibility will be accepted for damage sustained during the offloading from the vehicle or on the site thereafter.

All claims for damage and/or incomplete delivery must be reported to Nuair within two days of receipt of the equipment.

3.1 Offloading & Handling

The weight of the unit modules and palletised items are displayed on the packaging.

Some of the modules have an uneven weight distribution, and this will be indicated by labelling where appropriate.

Offloading and positioning of the equipment is the responsibility of the purchaser. Items should only be lifted by competent personnel following appropriate risk assessment.

1 Typical Loading Methods

Slings via spreaders fitted to unit with base frame.

Forklift

Assembly with base frame

Palletised

Please note that above images are examples of typical lifting methods. Actual unit lifting plan and risks must be assessed by competent personnel before moving the unit.

4.0 DIMENSIONS (mm) & WEIGHTS (kg)

2 DAVE Supply Unit Dimensions

Removable Weatherproof Control Cover			
Unit Code	Width	Height	Depth
DS(1-7)A-NNC	470	173	120
DS(1-2)A-LNC	649	183	216
DS3A-LNC	649	243	256
DS4A-LNC	649	251	256
DS(5-7)A-LNC	649	323	281
DS(1-7)A-ENC	530	178	175

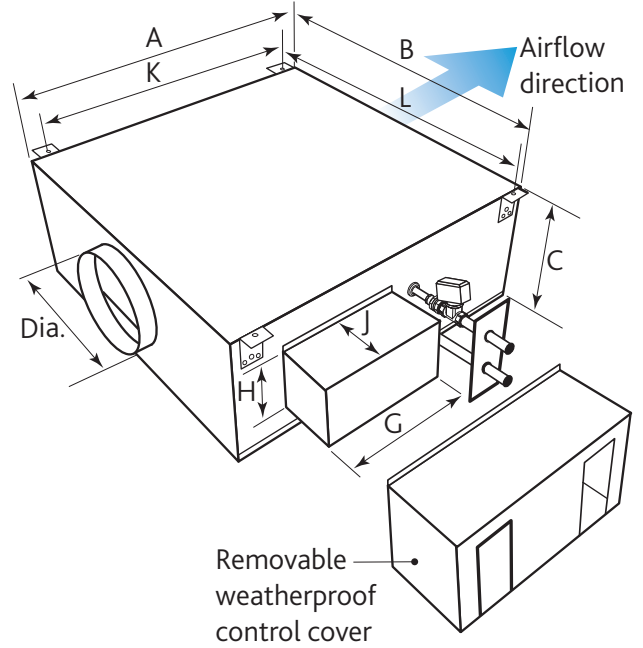

Unit Code	A	B	C	'D' Dia.	G	H	J	K	L	Weight (kg)
DS1A-NNC	1005	559	233	150	370	150	100	960	609	30
DS1A-LNC	1005	559	233	150	430	175	190	960	609	55
DS1A-ENC	1005	559	233	150	430	155	155	960	609	50
DS2A-NNC	1005	696	300	200	370	150	100	960	746	40
DS2A-LNC	1005	696	300	200	430	175	190	960	746	60
DS2A-ENC	1005	696	300	200	430	155	155	960	746	50
DS2HA-NNC	1005	696	300	200	370	150	100	960	746	40
DS2HA-LNC	1005	696	300	200	430	175	190	960	746	60
DS2HA-ENC	1005	696	300	200	430	155	155	960	746	50
DS3A-NNC	1005	780	345	200	370	150	100	960	830	45
DS3A-LNC	1005	780	345	200	430	175	190	960	830	65
DS3A-ENC	1005	780	345	200	430	155	155	960	830	55
DS4A-NNC	1005	840	370	250	370	150	100	960	890	50
DS4A-LNC	1005	840	370	250	430	175	190	960	890	70
DS4A-ENC	1005	840	370	250	430	155	155	960	890	60
DS4HA-NNC	1005	840	370	250	370	150	100	960	890	70
DS4HA-LNC	1005	840	370	250	430	175	190	960	890	70
DS4HA-ENC	1005	840	370	250	430	155	155	960	890	60
DS5A-NNC	1155	984	410	315	370	150	100	1110	1034	75
DS5A-LNC	1155	984	410	315	430	175	190	1110	1034	105
DS5A-ENC	1155	984	410	315	430	155	155	1110	1034	90
DS6A-NNC	1155	1092	455	400	370	150	100	1110	1142	80
DS6A-LNC	1155	1092	455	400	430	175	190	1110	1142	110
DS6A-ENC	1155	1092	455	400	430	155	155	1110	1142	90
DS7A-NNC	1155	1200	500	400	370	150	100	1110	1250	95
DS7A-LNC	1155	1200	500	400	430	175	190	1110	1250	120
DS7A-ENC	1155	1200	500	400	430	155	155	1110	1250	105

5.0 MECHANICAL INSTALLATION

Installation must be completed by competent persons, in accordance with good industry practice and should conform to all governing and statutory bodies i.e. IEE, CIBSE, etc.

External units must not be installed at an angle over 5° from the horizontal.

Mounting in the vertical orientation shown above IS NOT ADVISABLE for LPHW units due to the actuator being below the valve.

Service / Maintenance Access – Unit must be installed with a minimum of unit depth as additional clearance i.e. DS1A-NES either allow 233mm above or below unit.

When unit is installed in a location where it may be exposed to temperatures below 5°C, It is important to adequately insulate valve and pipework behind weather proof cover.

Access to the unit for maintenance is via the top or bottom lid, this should be taken into account before installation takes place (see important note below).

When weather cover is removed from control, always replace the removed fixings.

3 Incorrect Mounting Orientation (LPHW Units)

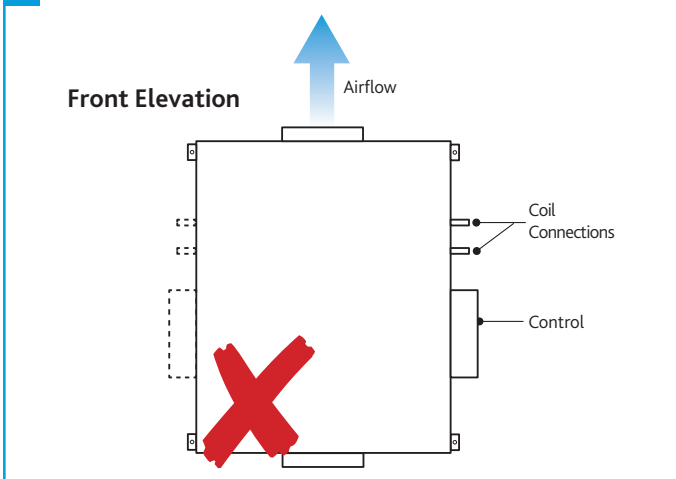

4 Unit Mounting Brackets (M8)

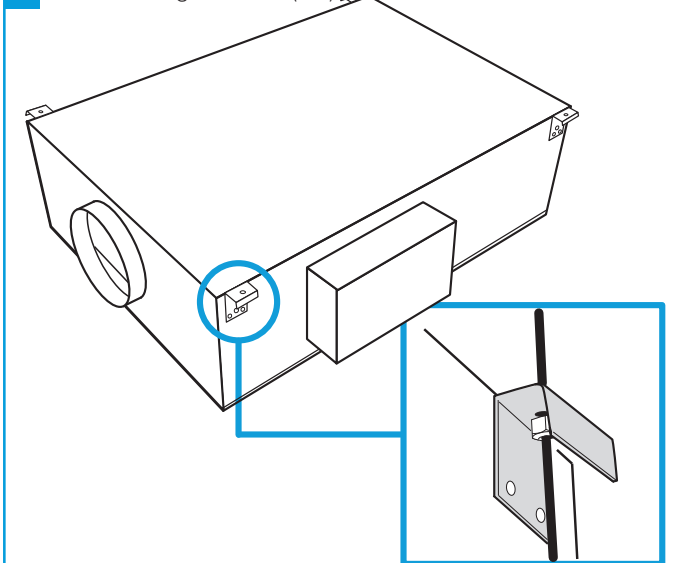

6.0 ELECTRICAL INSTALLATION

Isolation - Before commencing work, make sure that the unit and Nuair control are electrically isolated from the mains supply.

6.1 Unit Details

Unit details including Full Load Current, Voltage, fan speed etc. can be found on the unit label.

6.2 Wiring Diagrams

The wiring illustrations below are for units without control. All wiring is terminated in junction boxes fitted to the side of the unit.

Local isolator (by others)

Do not wire the power supply to motor via the motor alarm relay as terminals are only closed after the motor is energized.

The alarm relay on condensate may require the use of a contactor if the host equipment supply is switched.

5 Wiring - DS1-4 with No Heating

Key:

- Pre-Wired Connection —○—
- Factory Connection —○—
- Optional External Connection - - -○-
- Mandatory External Connection - - -○-

- A1 : Rotary Isolating Switch (Supplied by Customer.)
- A3 : Close to Open IO Damper (Supplied by Customer.)

W2 : Dirty Filter Alarm (Open = Alarm)

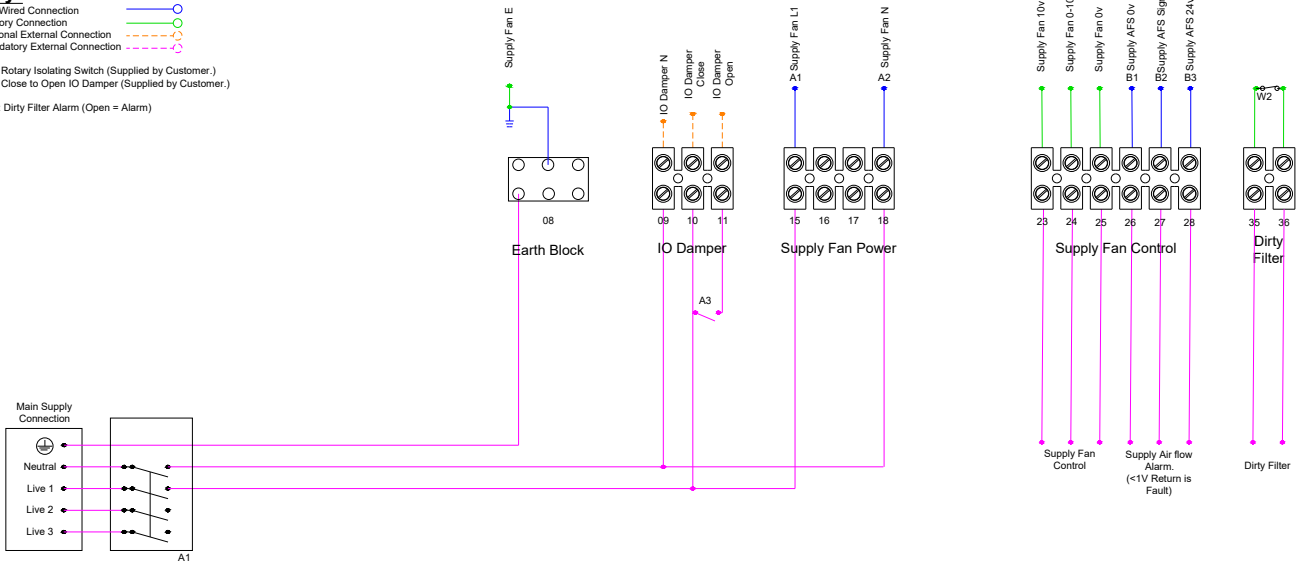

6 Wiring - DS5-7 with No Heating

Key:

- Pre-Wired Connection —○—
- Factory Connection —○—
- Optional External Connection - - -○-
- Mandatory External Connection - - -○-

- A1 : Rotary Isolating Switch (Supplied by Customer.)
- A3 : Close to Open IO Damper (Supplied by Customer.)

W1 : Supply Fan Alarm (Open = Alarm)

W2 : Dirty Filter Alarm (Open = Alarm)

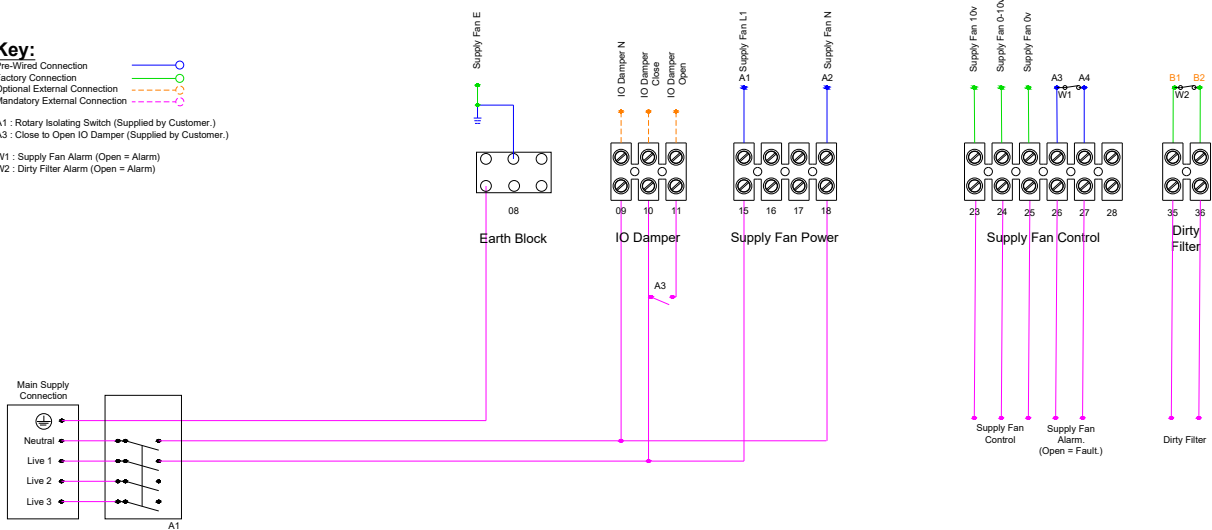

7 Wiring - DS1-4 with Electric Heating

Key:

- Pre-Wired Connection
- Factory Connection
- Optional External Connection
- Mandatory External Connection

A1 : Rotary Isolating Switch (Supplied by Customer.)
 A3 : Close to Open IO Damper (Supplied by Customer.)

S1 : Fresh Air Sensor
 S2 : Supply Air Sensor

W2 : Dirty Filter Alarm (Open = Alarm)
 W4 : Capillary Switch Manual Reset (Open = Alarm)

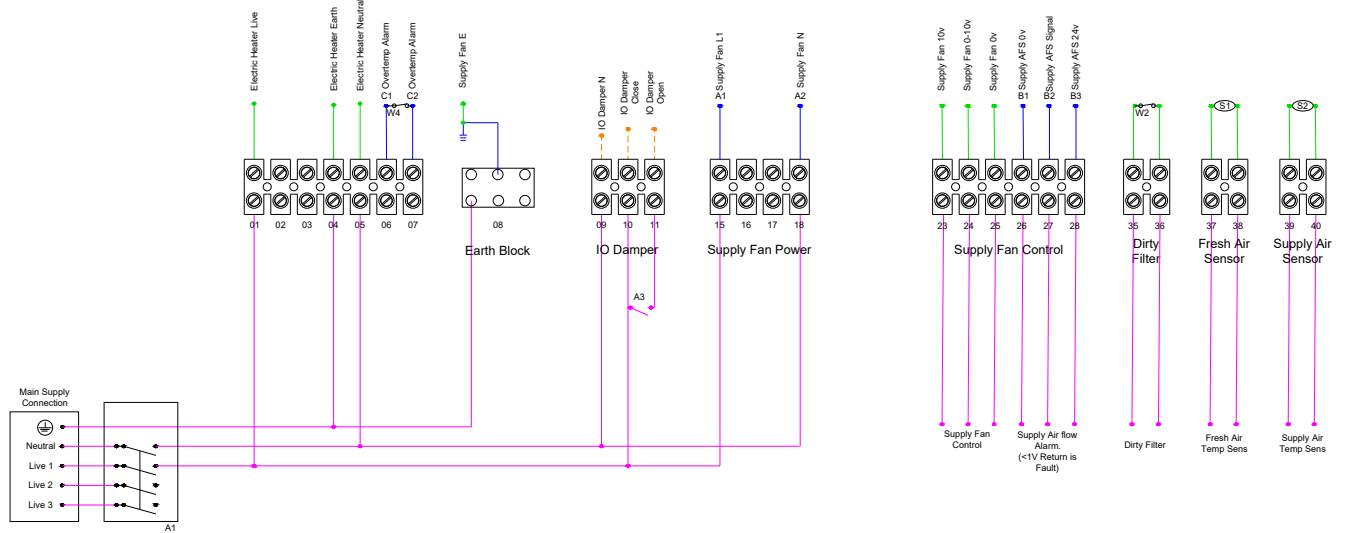

8 Wiring - DS5-7 with Electric Heating

Key:

- Pre-Wired Connection
- Factory Connection
- Optional External Connection
- Mandatory External Connection

A1 : Rotary Isolating Switch (Supplied by Customer.)
 A3 : Close to Open IO Damper (Supplied by Customer.)

S1 : Fresh Air Sensor
 S2 : Supply Air Sensor

W1 : Supply Fan Alarm (Open = Alarm)
 W2 : Dirty Filter Alarm (Open = Alarm)
 W4 : Capillary Switch Manual Reset (Open = Alarm)

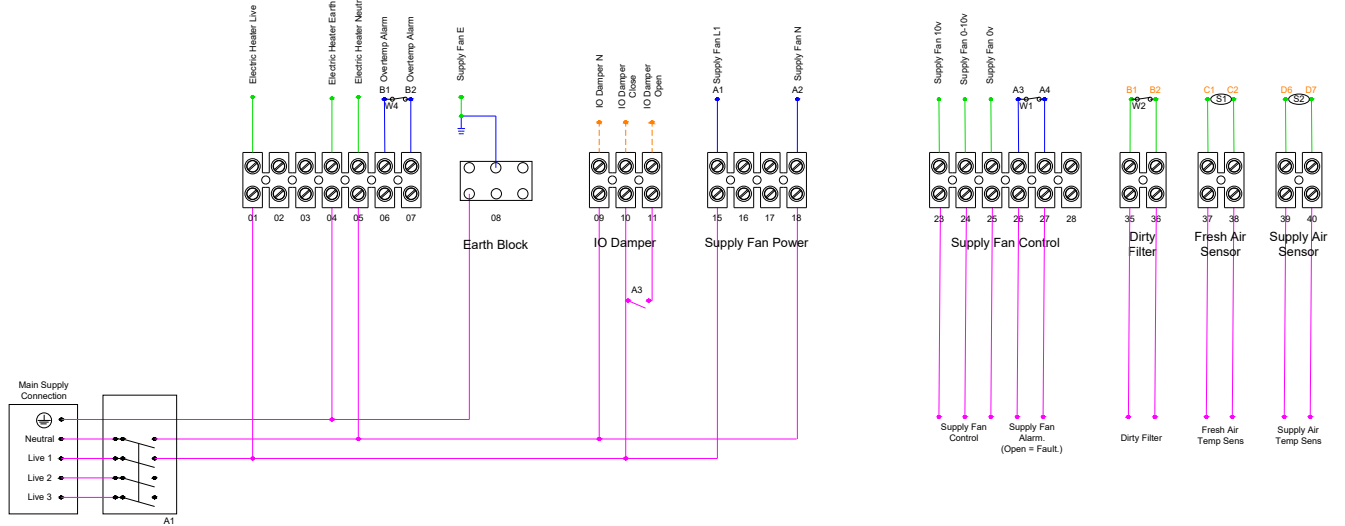

9 Wiring - DS1-4 with Electric Heating

Key:

- Pre-Wired Connection —○—
- Factory Connection —○—
- Optional External Connection - - -○- - -
- Mandatory External Connection - - -○- - -

A1 : Rotary Isolating Switch (Supplied by Customer.)
 A3 : Close to Open IO Damper (Supplied by Customer.)

S1 : Fresh Air Sensor
 S2 : Supply Air Sensor

W2 : Dirty Filter Alarm (Open = Alarm)
 W4 : Capillary Switch Manual Reset (Open = Alarm)

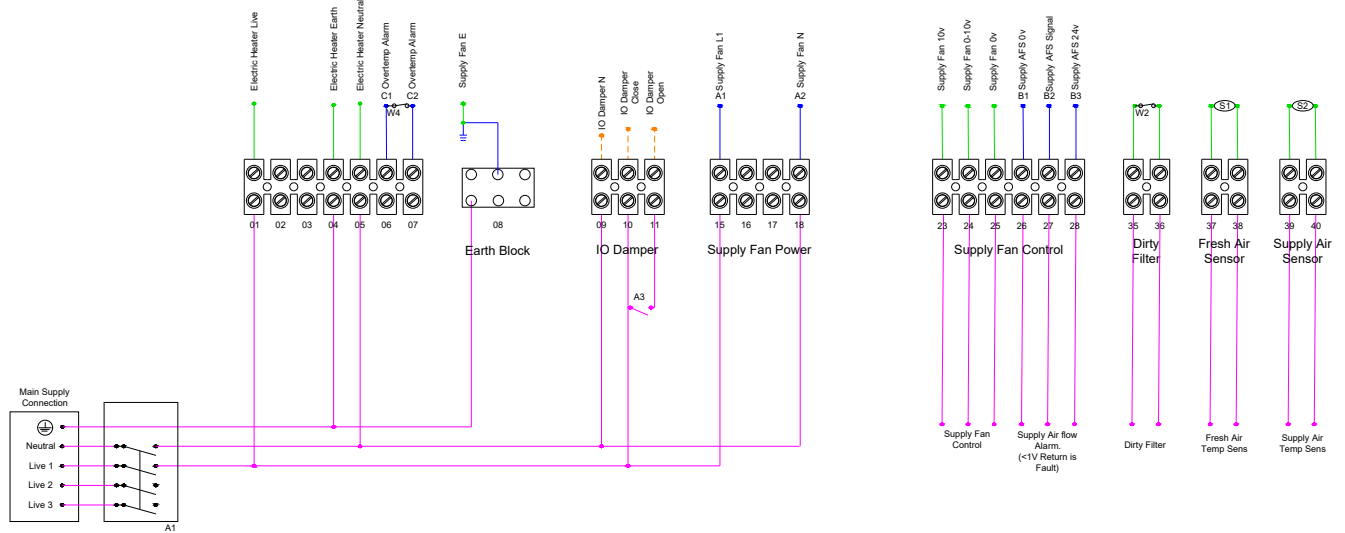

10 Wiring - DS5-7 with Electric Heating

Key:

- Pre-Wired Connection —○—
- Factory Connection —○—
- Optional External Connection - - -○- - -
- Mandatory External Connection - - -○- - -

A1 : Rotary Isolating Switch (Supplied by Customer.)
 A3 : Close to Open IO Damper (Supplied by Customer.)

S1 : Fresh Air Sensor
 S2 : Supply Air Sensor

W1 : Supply Fan Alarm (Open = Alarm)
 W2 : Dirty Filter Alarm (Open = Alarm)
 W4 : Capillary Switch Manual Reset (Open = Alarm)

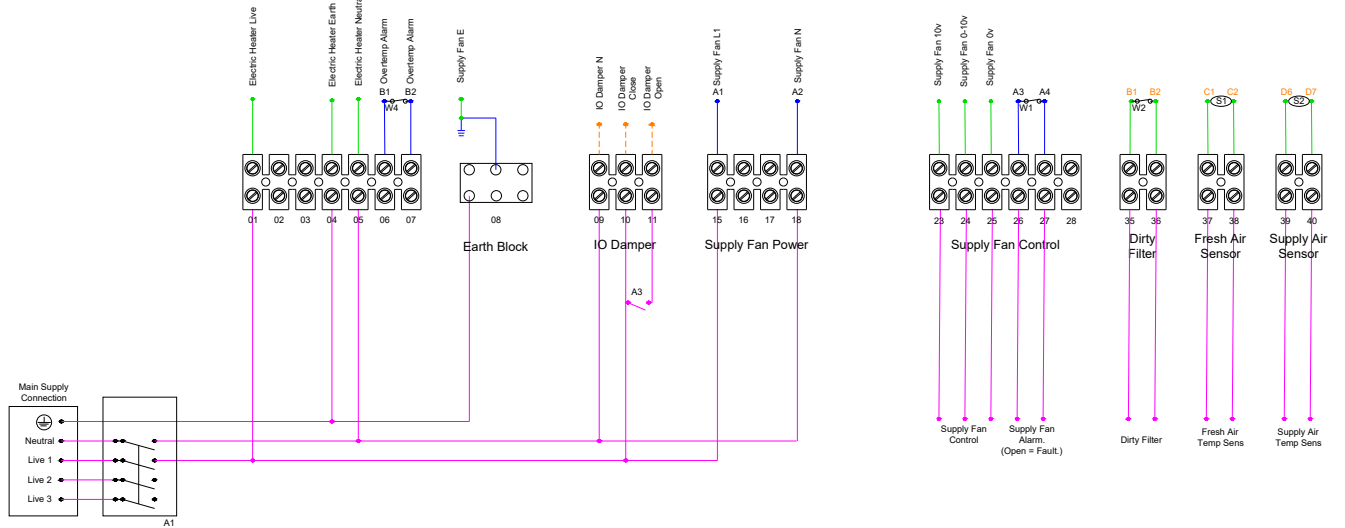

7.0 CONTROLS

The No Control (NC) units described in this manual are supplied without any controls. It is the installer's responsibility to select and install suitable controller(s) and circuit(s) to produce the desired output from the units while remaining within the units safe performance envelope.

All electric heater control systems must include an over temperature safety device rated at 80°C maximum. The fans should remain running for at least 4 minutes after the electric element is turned off to ensure the unit does not overheat.

8.0 MAINTENANCE

Isolation - Before commencing work, make sure that the unit and Nuair control are electrically isolated from the mains supply.

It is important that maintenance checks are recorded and that the schedule is always adhered to, in all cases, the previous report should be referred to.

Motors are fitted with sealed for life bearings and do not require any lubrication.

8.1 Routine Maintenance

- Remove the top or the bottom cover and carefully clean out the interior as necessary.
- Check all parts for security and that the impeller rotates freely, taking care not to disturb the balance.
- The filter (where applicable) will require cleaning on a regular basis. The frequency of the cleaning operation will depend on the site conditions.
- Ensure all control components are secure and clean.
- Refit the cover.

8.2 Annually

- All electrical terminals within the unit should be tightened.
- Check all earth connections.

8.3 Dirty Filter Alarm (Extended Case Models Only)

Units pre fitted with a panel air filter are equipped with an visual Red LED alarm on the side of the control. The pressure switch is pre set at 150pa and positioned within the unit and accessed via the removable top or bottom panel. If required, the alarm signal can be positioned to another area by others using the pre fitted terminal block - A volt free relay must be used between the control and customer wiring.

LED On = Pressure exceeds the maximum allowable final pressure drop.

Replacement filter part numbers are shown below.

8.4 G4 Filter Replacement

Unit	Replacement Part Number
DS1A	D1A-G4FILTERKIT
DS2A	D2A-G4FILTERKIT
DS2HA	D2HA-G4FILTERKIT
DS3A	D3A-G4FILTERKIT
DS4A	D3A-G4FILTERKIT
DS4HA	D4HA-G4FILTERKIT
DS5A	D5A-G4FILTERKIT
DS6A	D6A-G4FILTERKIT
DS7A	D7A-G4FILTERKIT

8.5 F7 Filter Replacement

Unit	Replacement Part Number
DS1A	D1A-G4FILTERKIT
DS2A	D2A-G4FILTERKIT
DS2HA	D2HA-G4FILTERKIT
DS3A	D3A-G4FILTERKIT
DS4A	D3A-G4FILTERKIT
DS4HA	D4HA-G4FILTERKIT
DS5A	D5A-G4FILTERKIT
DS6A	D6A-G4FILTERKIT
DS7A	D7A-G4FILTERKIT

8.6 Unit Components

Key	Components
A	Lid / Base
B	Attenuation Pods
C	Attenuation Pods Retaining Clips
D	G4 Filter, Optional F7 Filter (site removal)
E	Weather Cover for External Control Box Installation (If required)
F	LPHW Coil / 2 Port valve (PICV)
G	Electric Heater

11 Unit Components (No Heater)

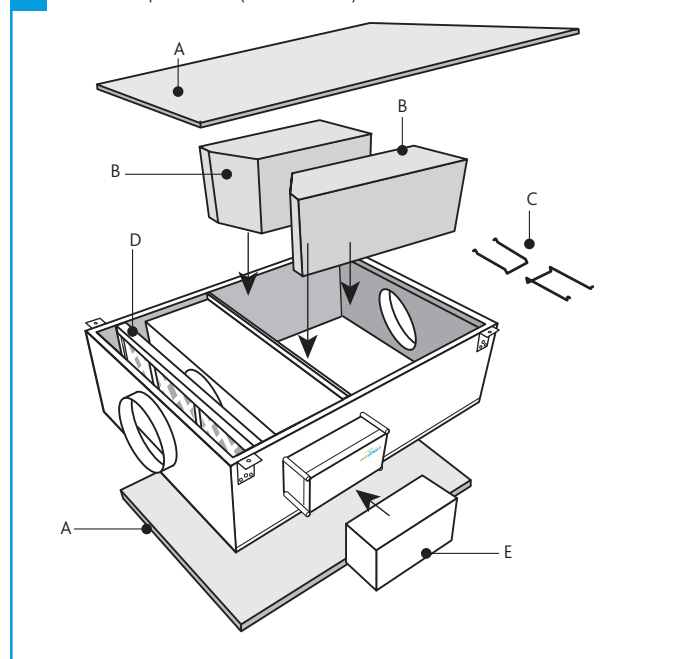

12 Unit Components (LPHW Heater)

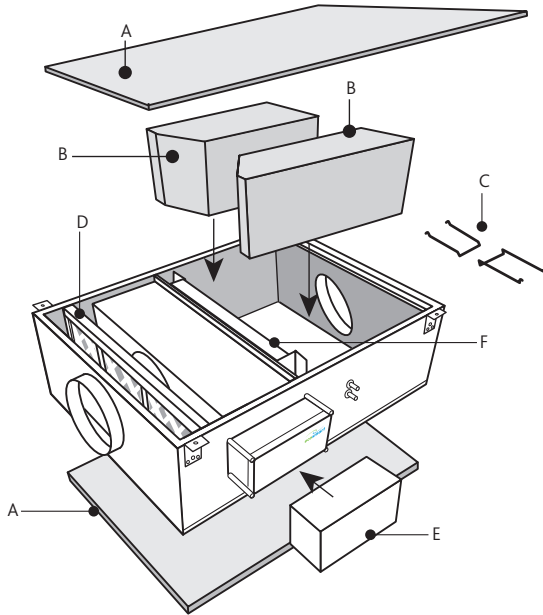

13 Unit Components (Electric Heater)

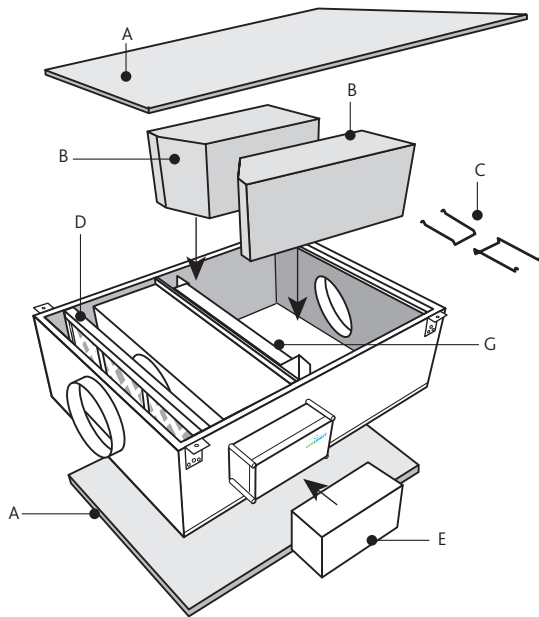

10.0 END-OF-LIFE AND RECYCLING

Ensure that Nuaire product is made safe from any electrical / water / refrigerant supplies before dismantling commences. This work should only be undertaken by a qualified person in accordance with local authority regulations and guidelines, taking into account all site based risks.

Where possible Nuaire use components which can be largely recycled when the product reaches its end-of-life:

- Fans, motors, controls, actuators, cabling and other electrical components can be segregated into WEEE recycling streams.
- Sheet metal parts, aluminium extrusion, heating/cooling coils and other metallic items can be segregated and fully recycled.
- EPP, plastic ducting, nylon corner pieces, plastic heat exchangers, packaging material and other plastic components can be segregated into mixed plastic and widely recycled.
- Cardboard packaging, wood, used filters and other paper components can be largely recycled or fully processed in energy from waste centres.
- Remaining Items can be further segregated and processed in accordance with the zero waste hierarchy. Please call After Sales Support for further information on items not listed above.

11.0 AFTER SALES AND REPLACEMENT PARTS

For technical assistance or further product information, including spare parts and replacement components, please contact the After Sales Department.

If ordering spares please quote the serial number of the unit together with the part number, if the part number is not known please give a full description of the part required. The serial number will be found on the identification plate attached to the unit casing.

Telephone 02920 858 400
aftersales@nuaire.co.uk

Technical or commercial considerations may, from time to time, make it necessary to alter the design, performance and dimensions of equipment and the right is reserved to make such changes without prior notice.

9.0 WARRANTY

The 5 year warranty starts from the day of delivery and includes parts and labour for the first year. The remaining period covers replacement parts only.

This warranty is void if the equipment is modified without authorisation, is incorrectly applied, misused, disassembled, or not installed, commissioned and maintained in accordance with the details contained in this manual and general good practice.

The product warranty applies to the UK mainland and in accordance with Clause 14 of our Conditions of Sale. Customers purchasing from outside of the UK should contact Nuaire International Sales office for further details.

Failure to maintain the unit as recommended will invalidate the warranty.



DECLARATION OF INCORPORATION

All parts except for moving parts requiring the correct installation of safety guards or incorporation into ducts or building fabrications acting as guards comply with the essential requirements of the Machinery (Safety) Regulations. The machinery shall not be put into service until the system has been declared to be in conformity with the provisions of the Supply of Machinery Regulations 2008 clauses 1.3.7 to 1.3.8.2 relating to guards/moving parts.

Product: Dave Supply Fans (All control variants)
Type: DS* (* denotes any suffix)
I&M Serial Number: 671679, 672044
Relevant EC Council Directives: 2006/42/EC (Machinery Directive);
Applied Harmonised Standards: BS EN ISO 12100, BS EN ISO 13857, EN60204-1, BS EN ISO 9001
Applied National Standards: BS848 Parts 1, 2.2 and 5.

The relevant technical documentation has been compiled in accordance with Annex VII (Part 7 of Schedule 2), part B. We undertake, in response to a reasoned request, to supply it in electronic form to the market surveillance authorities within a reasonable period.

Signature of manufacture representatives:

Name: Position: Date:
1) A. Thomas  Engineering Director 03. 04. 25.
2) C. Sargent  Manufacturing Director 03. 04. 25.

Basis of Self Attestation: BS EN ISO 9001, BSI Cert No. FM 665203
Nuaire: A Trading Division of Genuit, Western Industrial Estate, Caerphilly, CF83 1NA.

All standards used were current and valid at the date of signature.

INFORMATION FOR SAFE INSTALLATION, OPERATION AND MAINTENANCE OF NUAIRE VENTILATION EQUIPMENT

To comply with EC Council Directives 2006/42/EC Machinery Directive and 2014/30/EU (EMC). To be read in conjunction with the relevant product documentation (see 2.1)

1.0 GENERAL

- 1.1 The equipment referred to in this Declaration of Incorporation is supplied by Nuaire to be assembled into a ventilation system which may or may not include additional components. The entire system must be considered for safety purposes and it is the responsibility of the installer to ensure that all of the equipment is installed in compliance with the manufacturers recommendations and with due regard to current legislation and codes of practice.

2.0 INFORMATION SUPPLIED WITH THE EQUIPMENT

- 2.1 Each item of equipment is supplied with a set of documentation which provides the information required for the safe installation and maintenance of the equipment. This may be in the form of a Data sheet and/or Installation and Maintenance instruction.
- 2.2 Each unit has a rating plate attached to its outer casing. The rating plate provides essential data relating to the equipment such as serial number, unit code and electrical data. Any further data that may be required will be found in the documentation. If any item is unclear or more information is required, contact Nuaire.
- 2.3 Where warning labels or notices are attached to the unit the instructions given must be adhered to.

3.0 TRANSPORTATION, HANDLING AND STORAGE

- 3.1 Care must be taken at all times to prevent damage to the equipment. Note that shock to the unit may result in the balance of the impeller being affected.
- 3.2 When handling the equipment, care should be taken with corners and edges and that the weight distribution within the unit is considered. Lifting gear such as slings or ropes must be arranged so as not to bear on the casing.
- 3.3 Equipment stored on site prior to installation should be protected from the weather and steps taken to prevent ingress of contaminants.

4.0 OPERATIONAL LIMITS

- 4.1 It is important that the specified operational limits for the equipment are adhered to e.g. operational air temperature, air borne contaminants and unit orientation.
- 4.2 Where installation accessories are supplied with the specified equipment eg. wall mounting brackets. They are to be used to support the equipment only. Other system components must have separate provision for support.
- 4.3 Flanges and connection spigots are provided for the purpose of joining to duct work systems. They must not be used to support the ductwork.
- 4.4 Local Environment - Humidity. Ambient humidity (the humidity at the unit's installed location) shall be within the range: 10 to 95% (for controls, non-condensing). Air humidity (the humidity of the air passing through the unit) shall be within the range: 10 to 95% (for controls, non-condensing).

5.0 INSTALLATION REQUIREMENTS

In addition to the particular requirements given for the individual product, the following general requirements should be noted.

- 5.1 Where access to any part of equipment which moves, or can become electrically live are not prevented by the equipment panels or by fixed installation detail (e.g. ducting), then guarding to the appropriate standard must be fitted.
- 5.2 The electrical installation of the equipment must comply with the requirements of the relevant local electrical safety regulations.
- 5.3 For EMC all control and sensor cables should not be placed within 50mm or on the same metal cable tray as 230V switched live, lighting or power cables and any cables not intended for use with this product.

6.0 COMMISSIONING REQUIREMENTS

- 6.1 General pre-commissioning checks relevant to safe operation consist of the following:
- Ensure that no foreign bodies are present within the fan or casing.
 - Check electrical safety, e.g. insulation and earthing.
 - Check guarding of system.
 - Check operation of Isolators/Controls.
 - Check fastenings for security.
- 6.2 Other commissioning requirements are given in the relevant product documentation.

7.0 OPERATIONAL REQUIREMENTS

- 7.1 Equipment access panels must be in place at all times during operation of the unit, and must be secured with the original fastenings.
- 7.2 If failure of the equipment occurs or is suspected then it should be taken out of service until a competent person can effect repair or examination. (Note that certain ranges of equipment are designed to detect and compensate for fan failure).

8.0 MAINTENANCE REQUIREMENTS

- 8.1 Specific maintenance requirements are given in the relevant product documentation.
- 8.2 It is important that the correct tools are used for the various tasks required.
- 8.3 If the access panels are to be removed for any reason the electrical supply to the unit must be isolated.
- 8.4 A minimum period of two minutes should be allowed after electrical disconnection before access panels are removed. This will allow the impeller to come to rest.
NB: Care should still be taken however since airflow generated at some other point in the system can cause the impeller to "windmill" even when power is not present.
- 8.5 Care should be taken when removing and storing access panels in windy conditions.