



SC

Short Cased Axial Flow Fans Installation Manual



1.0 SAFETY INFORMATION

- The provision of the electrical supply and the connection of the unit to the mains must be carried out by a qualified electrician.
- Isolate from power supply before removing any covers. During installation / maintenance ensure all covers are fitted before switching on the mains supply.
- All-pole disconnection from the mains as shown in the wiring diagram must be incorporated within the fixed wiring and shall have a minimum contact separation of 3mm in accordance with latest edition of the wiring regulations.
- This unit must be earthed.
- Ducting must be securely fixed with screws to the spigot to prevent access to live parts. Duct runs terminating close to the fan must be adequately protected by suitable guards.
- Precautions must be taken to avoid the back-flow of gases into the room from the open flue of gas or other fuel-burning appliances.
- This appliance should not be used by children or persons with reduced physical, sensory or mental capabilities or lack of experience and knowledge, unless they have been given supervision or instruction concerning the safe use of the appliance by a person responsible for their safety. Children shall not play with the appliance. Cleaning and user maintenance shall not be carried out by children.

1.1 Hazard Symbols



GENERAL WARNING

Signifies a general warning regarding hazard specified by supplementary information.



ELECTRIC SHOCK

This unit must be completely electrically isolated before any panels are removed. Check mains supply and control connections.



ROTATING PARTS

This unit contains fast moving rotational parts which may start automatically. It is the sole responsibility of the installer to adequately guard these components.



REFER TO INSTRUCTION MANUAL

Read and understand the installation and maintenance manual before installing, operating or maintaining this product.

1.2 Important Information

This manual contains important information on the safe and appropriate assembly, transport, commissioning, operation, maintenance, disassembly and simple troubleshooting of the product.

While the product has been manufactured according to the accepted rules of current technology, there is still a danger of personal injury or damage to equipment if the following general safety instructions and the warnings contained in these instructions are not complied with.

- **Read these instructions completely and thoroughly before working with the product.**
- **Keep these instructions in a location where they are accessible to all users at all times.**
- **Always include the operating instructions when you pass the product on to third parties.**

1.3 Personal Protective Equipment

The following minimum Personal Protective Equipment (PPE) is recommended when interacting with Nuaire product:

- **Protective Steel Toed Shoes** - when handling heavy objects.
- **Full Finger Gloves (Marigold PU800 or equivalent)** - when handling sheet metal components.
- **Semi Fingerless Gloves (Marigold PU3000 3DO or equivalent)** - when conducting light work on the unit requiring tactile dexterity.
- **Safety Glasses** - when conducting any cleaning/cutting operation or exchanging filters.
- **Reusable Half Mask Respirators** - when replacing filters which have been in contact with normal room or environmental air.

Nuaire would always recommend a site specific risk assessment by a competent person to determine if any additional PPE is required.

2.0 INTRODUCTION

The Nuaire Short Cased Axial Fan range is produced in a range of sizes from 250mm to 1600mm diameter.

Cases are manufactured from various materials such as pre-galvanised steel, stainless steel or hot dipped galvanised steel. Impellers are selected to meet the specific performance and are available in a variety of materials to ensure suitability for the application.

Units are available for single and three phase supply.

3.0 DELIVERY & HANDLING

All equipment is inspected prior to despatch and leaves the factory in good condition. Upon receipt of the equipment an inspection should be made and any damage indicated on the delivery note. Particulars of damage and/or incomplete delivery should be endorsed by the driver delivering the goods before offloading by the purchaser.

No responsibility will be accepted for damage sustained during the offloading from the vehicle or on the site thereafter. All claims for damage and/or incomplete delivery must be reported to Nuaire within two days of receipt of the equipment.

The fan impeller is carefully balanced prior to despatch and great care must be exercised when handling the unit.

This will ensure that the case is not damaged or distorted, causing the impeller to foul against the casing. The fan should be stored on a flat surface and the impeller rotated at regular intervals.

Any damages or deviations should be immediately reported to the seller/supplier/agent quoting the order and product details from the product rating plate.

1 Unit Lifting

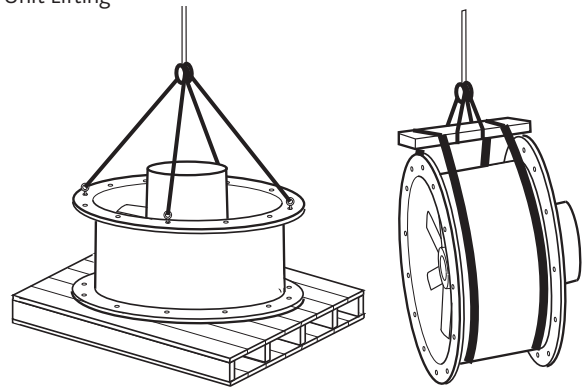

4.0 MECHANICAL INSTALLATION

Installation must be carried out by competent personnel in accordance with good industry practice, the appropriate authority and in conformance with all statutory and governing regulations.

Before commencing installation check that all material, including optional ancillaries are available to complete the installation. Every unit is tested and serialised at works and a test certificate produced, the details recorded on the fan side rating plate should also be referred to before handling and installation.

Any damages or deviations should be immediately reported to the seller/supplier/agent quoting the order and product details from the product rating plate.

Prior to installation the impeller should be rotated by hand to ensure free and smooth rotation and that no transit or handling damage has occurred.

Ensure that impeller and motor are free from obstruction and that all optional accessories such as guards and bell mouths are securely fastened before commencing unit start up.

When operating at low temperatures, ice formation can occur, and suitable prevention should be adopted to avoid ice build up.

Suitable heater jackets are advised that cover the entire circumference of the impeller area. Blocking or partial blocking of guard areas must be avoided to prevent uneven airflow through the ventilator.

In order to ensure performance is as stated, a minimum distance of twice the fan diameter is required between the appliance and any bends in the ductwork.

4.1 Mechanical Loading

Units are not designed to support the weight of any other structure or equipment, and should not be subject to mechanical loading or vibration levels beyond that associated with their application. This condition includes the support of ducting, attenuators and other connected ancillary items unless specifically provided for (Note: connection points may be provided, but this does not imply the provision for mechanical support).

4.2 Unit Modification

Physical modification of any kind without published instruction or prior engineering approval may compromise unit operation and safety and will automatically invalidate the product warranty.

4.3 Drain Plugs

Motors are supplied with 2 (two) drain holes. Located at drive end and non-drive end of the motor.

Nuaire recommend that the drain holes are plugged to suit the fan mounting application, these drain plugs when changed should be **fitted with a torque setting of 10Nm**.

Motors are fitted with drain plugs to prevent the build up of condensation. The type & orientation of these drain plugs is covered further in Sections 4.12 and 4.13.

4.4 Coil Applications and Obstruction to Airflow

The minimum recommended distance from any installation obstruction to the inlet or outlet plane of the fan is 1 (one) fan diameter.

If any permanent or temporary obstruction is present within this distance, or otherwise at greater distance and results in either a non-uniform flow distribution to or from the fan, or a variable flow quantity, the operational and structural integrity of the fan may be severely compromised.

In such cases, it is the responsibility of the system designer to ensure that no detrimental effect is encountered and Nuaire will accept no liability for product failure.

4.5 Motors

Supplied as standard are motors that are enclosure protection certified to IP56 standards.

This certification allows for the following conditions:

- Water delivery rate: 105 l/minute maximum
- Water pressure: 1 bar maximum (assuming 12.5mm plain nozzle)
- Duration: 3 minutes
- Distance to motor: 3m minimum
- Maximum water temperature: 40°C

Wash down cleaning of the ventilator should be with water only as no cleaning fluids or additives are permitted.

Should a specification exceed these requirements, alternative enclosure protection levels can be advised on request.

All bearings are pre-packed with grease and sealed for life requiring no further lubrication.

4.6 Connection Details

Electrical connections are made directly to the motor terminal box as standard. Check that the voltage on the fan rating label is suitable for your supply. Full load and starting currents are also indicated.

Motors below 4kW are designed for Direct On Line starting whilst 4kW and above are suitable for Direct On Line or Star/Delta starting.

4.7 Start Up Procedure

On start up ensure the impeller rotation follows the arrow indicator on the fan casing. Should the direction be incorrect on a three phase unit reverse any two of the supply leads.

Single phase rotational direction is set at the factory and should not be altered. Equipment should be run for approximately 30 minutes to ensure correct operation.

If any fault occurs the equipment should be switched off and not re-started until the fault has been rectified.

4.8 Reversing Fans

If the unit is specified as 'reversing fan' care must be taken when designing the control gear to ensure that enough time is allowed for the fan impeller to come to a standstill before switching to the opposite rotation.

4.9 Windmilling

Care must be taken to ensure that reverse windmilling does not occur prior to start up. This condition can cause damage to impellers & motors, which may shorten service life or lead to failure.

4.10 Starting and Stopping

The control system shall be engineered to prevent more than 10 stop / start operations in any 1 hour period.

Where it is not possible to arrange this under automatic control, the minimum acceptable provision is to make this limiting factor clear in the Operation Manual for the building services system or Plant within which our Products are fitted.

4.11 Guarding

A guarding arrangement appropriate to the application must be determined by the System Designer, using a risk assessment based approach.

The guarding system selected must prevent operator contact with moving or otherwise hazardous parts, but must also provide containment in the eventuality of structural failure. Provision for containment guarding must in any case be provided for overhead unit mounting, and is also required for installations that may encounter periodic ice build-up and / or occasional contact of solid bodies with rotating parts.

4.12 Vertical Mounting

With vertically mounted axial fans (Figure 2).

- The drain hole positioned at the lowest part on the motor (A) should be fitted with a capillary drain plug (Figure 2).
- The drain hole that is positioned at the highest point on the motor (B) should be fitted with a standard (non-capillary) drain plug (Figure 2).

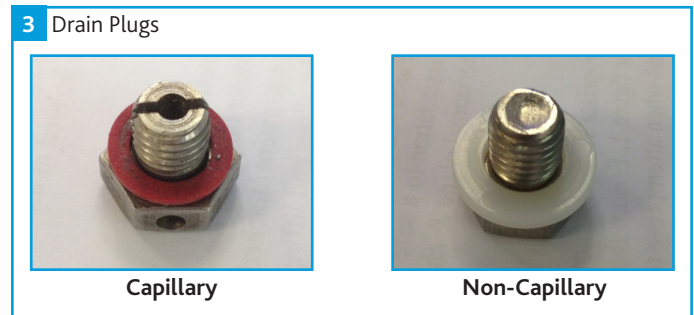
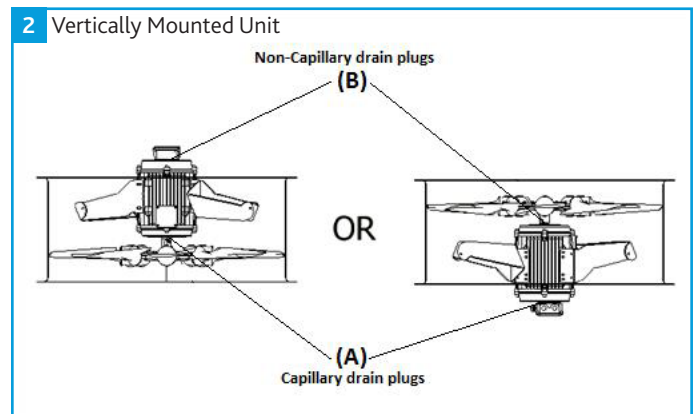

4.13 Horizontal Mounting

With horizontal mounted axial fans (Figure 4).

- Both drain holes should be fitted with standard (non-capillary) drain plugs (Figure 4).
- Nuair recommends that the additional underside plastic drain plugs (not shown) are removed at service periods to allow condensation to drain. These should not be removed during process working or clean down periods.

4 Horizontally Mounted Unit

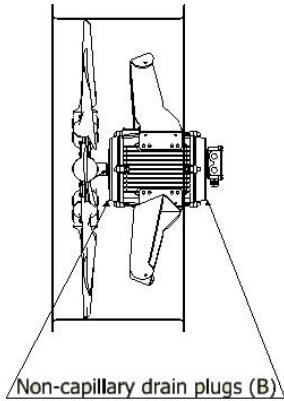

5.0 ELECTRICAL INSTALLATION

Isolation - Before commencing work, make sure that the unit, switched live and Nuair controls are electrically isolated from the mains supply.

If motor overheat protection is specified, terminals T1 and T2 must be connected to the fan control circuit. Failure to do so will invalidate the warranty.

For good EMC engineering practice, any sensor cables or switched live cables should not be placed within 50mm of other cables or on the same metal cable tray as other cables.

For D.O.L starting of 4kW and above, 3ph, the final connection must be in DELTA. If a STAR/DELTA starter is to be used connect all six motor terminals to the appropriate terminals of the starter.

Units are not supplied with electrical isolators, their selection and provision is the responsibility of the installer.

Ensure the electrical supply is suitable for the fan and that all wiring, fuse and overload protection etc. is appropriately sized by comparing with the rating plate.

Electrical connection is made direct to the motor terminal box.

5.1 Wiring Diagrams

5.1.1 Single Phase

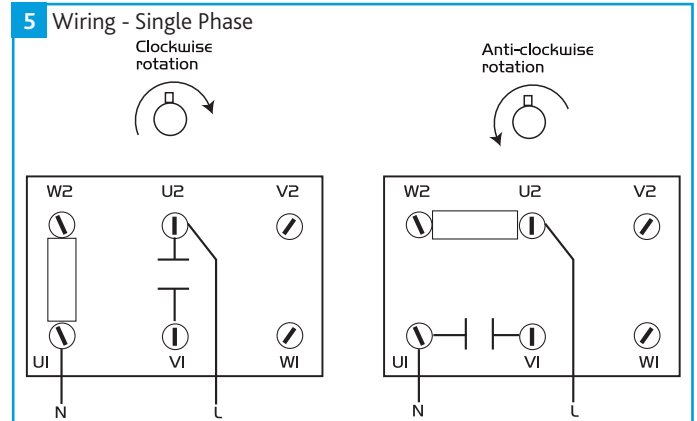

5.1.2 Three Phase (3kW and Below)

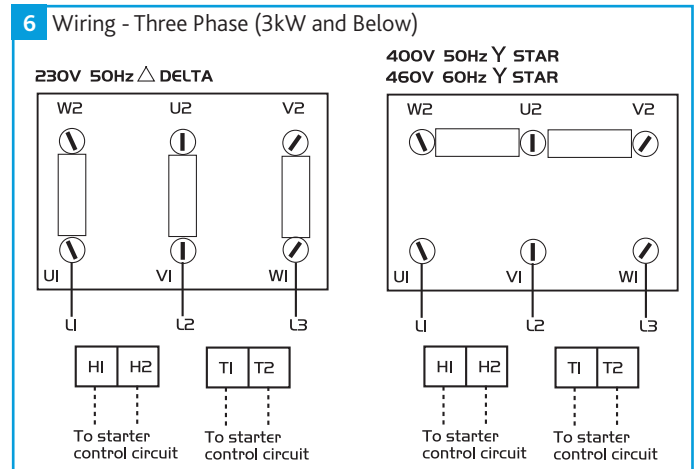

5.1.3 Three Phase (4kW and Above)

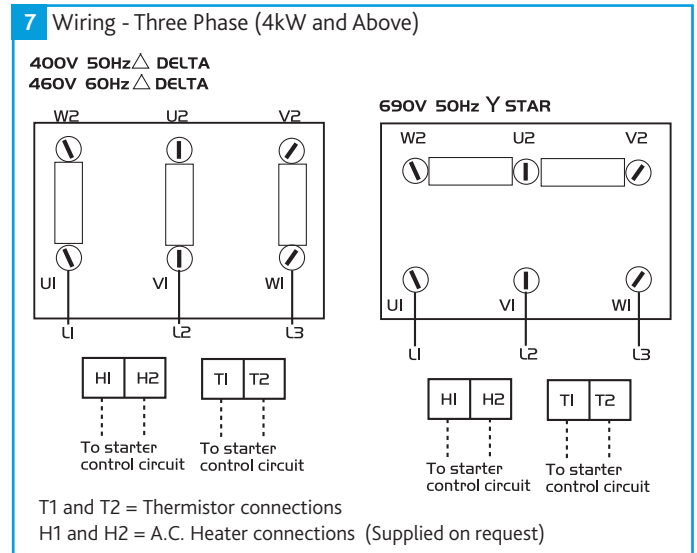

6.0 EXTENDED STORAGE

General advice is as follows:

Fan products designed for environmental ventilation of a completed structure must not be used during site construction or the 'clean-up' period. Cement and plaster dust is extremely abrasive and can advance bearing wear.

Where fans are to be put in to service for commissioning they must be protected from the airborne contaminants prevalent under construction site conditions.

Where fans are to be put in to 'normal' service in a completed or part completed building the end user, tenant, occupier etc. must be informed of the maintenance requirements detailed in the relevant product installation and maintenance documents.

Where fans are to be stored or bonded for extensive periods either in warehouse, under site conditions or in the installed state we make the following additional recommendations; Motors should be stored at ambient temperatures between -16°C and +50°C and at relative humidity (RH) below 90% RH.

- **Turn fan and motor shafts at three monthly intervals to prevent the brinelling effect on the bearings. Brinelling is a flattening or settlement of the shaft in the bearing housing.**

For extensive storage periods and particularly where the motors may be exposed to high RH levels, special precautions and restart requirements may be required. For further advice contact the Nuair technical help line below.

7.0 MAINTENANCE

It is the responsibility of the System Designer and Plant Operator to determine an appropriate inspection routine for industrial products.

It is suggested that an inspection interval for the wide range of application types encountered for this type of product may be determined by the following procedure :-

- **Initial inspection after one week of operation.**
- **Secondary inspection after one month of operation.**
- **Subsequent inspection interval between one month and six months depending on the degree of contamination and/or operational stress encountered.**

The inspection shall consist of observation of the fan operation (through a representative operational cycle) to establish if adverse vibration exists.

Vibration limits should be defined by the system designer with regards to the specific application design. As guidance the manufacturer recommends that on start-up, velocity limits of no greater than 5mm/s RMS are accepted.

Alarm limits are recommended for no greater than 8mm/s RMS where inspection and/or shut down must occur.

With the fan isolated, an examination of all unit fixings, services connections and structural components shall be made. In addition, operational clearances between moving and stationary parts shall be checked. The tip if the impeller to case minimum dimension is outlined in table 2.

Any superficial build-up of contaminants should be removed as necessary to facilitate inspection, and any defects noted and assessed.

The unit must not be operated if any structural or rotating parts are found to be in a defective condition.

The unit must be maintained in a clean condition by using soft cleaning tools and water as required.

8.0 REPLACING THE MOTOR

This replacement of motor section refers to Nuair's IE3 pad mounted motor range. For guidance on IE2 refer to document 671850, for other motor variants, contact the manufacturer for details. Specific values may be different.

Thoroughly examine the goods upon receipt and immediately report any damages or deviations to the seller, supplier or agent quoting the order and product details from the rating plate.

Ensure that the installation is isolated in a safe manner and cannot be re-energised by any other party when the installation is being worked on. Also ensuring all other connecting components of the system are isolated in the same manner i.e. other fans, dampers etc.

Where eye-bolts are provided with the motor, these are designed to support the weight of the motor only, and should not be used to support the weight of the motor and any ancillary equipment attached to the unit. Be absolutely sure that cranes, jacks, slings and lifting beams are capable of carrying the weight of equipment to be lifted.

If suitable lifting equipment cannot be used within the installation, remove the unit from the installation to a safe working area, placing the unit in the horizontal plane and chock securely.

Tip to casing clearance must be even around the whole of the case.

1. Using suitable gloves and an appropriate socket, remove the impeller retaining bolt. Ensure that the impeller is restrained by hand when attempting to undo the bolt.
2. The impeller is free to be slid from the motor shaft. This must be done by supporting the impeller until it is completely free from the motor shaft, allowing the full weight of the impeller to bear on a short length of the bore may cause distortion or create a burr that will bind the impeller and prevent total removal. Disconnect the electrical supply from the terminal box to the motor.
3. Disconnect the conduit at the end of the case (if provided); attach a suitable lifting strap to the motor lifting point using appropriate D shackles. Attach a lifting system of sufficient capacity to a lifting strap and remove any slack in the strap. Loosen the pad to motor fixings, gently raise the motor.
4. Remove all motor fixings (either side of the motor), ease the motor clear of the fan casing then lower onto a suitable pallet for removal.
5. Motor installation is the reverse of removal.
6. If using stainless steel cap head screws, Loctite 290 thread locker should be applied to each screw prior to fitting (provided by others).
7. The cap head screws must be tightened as per manufacturer's recommendations shown in table 1.
8. Centralise the motor within the casing, the tip clearance must be set evenly around the whole of the case; this is extremely important due to the expansion rates of the materials involved.
9. Wire the replacement motor to the termination enclosure. Conduct all electrical safety checks.

Refit the impeller retaining bolt and washer, having first applied Loctite 290 thread locker to the thread (provided by others).

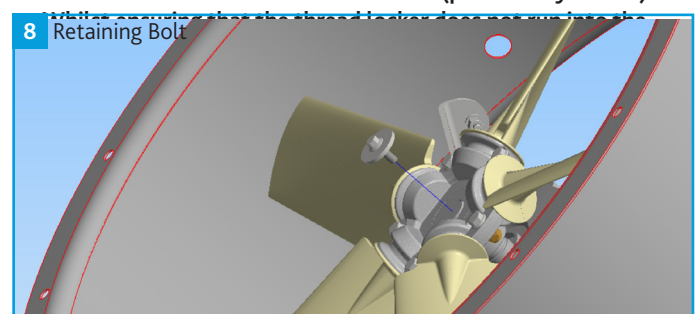

9 Motor Fixings

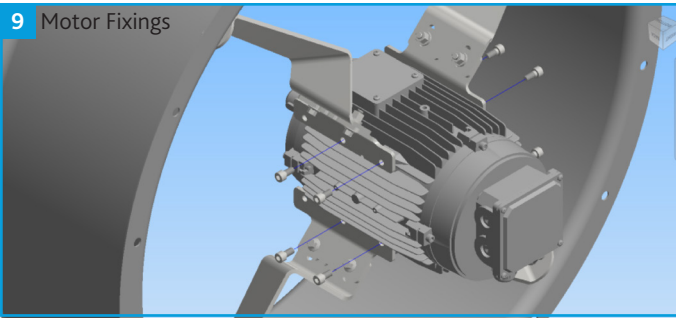

Impeller Retaining Bolt Torque Settings	
Bolt Size	Torque Setting (Nm)
M12	85
M16	210
M20	300

8.1 Points of Caution

- The centre bolt may be tight initially due to the presence of Loctite.
- Having removed the centre bolt and washer, spray the hub centre with WD40, whilst avoiding the bearing area.
- Support the impeller until it is fully removed, ensuring that weight does not bear on a partial area of the hub.
- Should the impeller bind part way, apply WD40 and ease back on. Then attempt again to remove the impeller fully. Never drive off the impeller as this may cause damage to the impeller and motor bearings.
- Take care not to damage or distort the fan blades, These may be of thin section possibly leading to severe imbalance during operation.
- Clean drive shaft thoroughly before attempting to re-fit the impeller.
- Should difficulty be experienced when re-fitting the impeller, attempt to fit with the key removed and check that the key fits in the hub separately. **Note- the key must be fitted prior to powered operation.**
- When the impeller is fitted, check for any free play in the hub, any of free play may cause imbalance during operation. Should free play be found, contact the manufacturer for assistance.
- Never force the impeller onto the shaft.**

9.0 WARRANTY

This product comes with a 1 year warranty. The warranty starts from the day of delivery and includes parts and labour for the first year.

This warranty is void if the equipment is modified without authorisation, is incorrectly applied, misused, disassembled, or not installed, commissioned and maintained in accordance with the details contained in this manual and general good practice.

The product warranty applies to the UK mainland and in accordance with Clause 14 of our Conditions of Sale. Customers purchasing from outside of the UK should contact Nuaire International Sales office for further details.

Failure to maintain the unit as recommended will invalidate the warranty.

10.0 END-OF-LIFE AND RECYCLING

Where possible Nuaire use components which can be largely recycled when the product reaches its end-of-life:

- Fans, motors, controls, actuators, cabling and other electrical components can be segregated into WEEE recycling streams.

Pad to Motor Cap Head Bolt Torque Settings	
Motor Frame Size	Torque Setting (Nm)
80	8
90	16
100	16
112	20
132	40
160	45

Impeller Tip to Case Minimum Clearance	
Case Diameter (mm)	Minimum Tip Clearance (mm)
250	1
315	2
350	2
400	2
450	2
500	2
560	2
630	2
710	2.5
800	3
900	3.5
1000	4
1120	5
1250	6

Impeller Retaining Bolt Torque Settings	
Bolt Size	Torque Setting (Nm)
M4	3
M5	6
M6	10
M8	24
M10	49

- Sheet metal parts, aluminium extrusion, heating/cooling coils and other metallic items can be segregated and fully recycled.
- Cardboard packaging, wood, used filters and other paper components can be largely recycled or fully processed in energy from waste centres.
- Remaining items can be further segregated for energy from waste centres or, as a last resort, sent to landfill. Please call After Sales Support for further information on items not listed above.

Ensure that Nuairé product is made safe from any electrical / water / refrigerant supplies before dismantling commences. This work should only be undertaken by a qualified person in accordance with local authority regulations and guidelines, taking into account all site based risks.

11.0 AFTER SALES AND REPLACEMENT PARTS

For technical assistance or further product information, including spare parts and replacement components, please contact the After Sales Department.

If ordering spares please quote the serial number of the unit together with the part number, if the part number is not known please give a full description of the part required. The serial number will be found on the identification plate attached to the unit casing.

Telephone 02920 858 400
aftersales@nuaire.co.uk

Technical or commercial considerations may, from time to time, make it necessary to alter the design, performance and dimensions of equipment and the right is reserved to make such changes without prior notice.



EU DECLARATION OF INCORPORATION AND INFORMATION FOR SAFE INSTALLATION, OPERATION AND MAINTENANCE

We declare that the machinery named below is intended to be assembled with other components to constitute a system of machinery. All parts except for moving parts requiring the correct installation of safety guards comply with the essential requirements of the Machinery Directive. The machinery shall not be put into service until the system has been declared to be in conformity with the provisions of the EC Machinery Directive.

Product: SHORT CASE AXIAL FAN
Type: SC
Relevant EU Council Directives: 2006/42/EC (MACHINERY DIRECTIVE)

Applied EU Harmonised Standards: EN 60204-1:2006+A1:2009+AC:2010;
 EN ISO 12100:2010; EN ISO 13857:2008;
 EN ISO 9001:2015

Signature of manufacture representatives:

Name:	Position:	Date:
1) A. Thomas 	Technical Director	06. 08. 21
2) C. Sargent 	Manufacturing Director	06. 08. 21

Basis of Self Attestation: BS EN ISO 9001, BSI Cert No. FM 665203

Nuaire: A Trading Division of Polypipe, Western Industrial Estate, Caerphilly, CF83 1NA.

EU Authorised Representative: Eurolink Europe Compliance Limited, 25 Herbert Place, Dublin D02 AY86, Republic of Ireland.

All standards used were current and valid at the date of signature.

INFORMATION FOR SAFE INSTALLATION, OPERATION AND MAINTENANCE OF NUAIRE VENTILATION EQUIPMENT

To comply with EC Council Directives 2014/30/EU (EMC), 2014/35/EU (Low Voltage Directive). To be read in conjunction with the relevant product documentation (see 2.1)

1.0 GENERAL

1.1 The equipment referred to in this Declaration of Incorporation is supplied by Nuaire to be assembled into a ventilation system which may or may not include additional components. The entire system must be considered for safety purposes and it is the responsibility of the installer to ensure that all of the equipment is installed in compliance with the manufacturers recommendations and with due regard to current legislation and codes of practice.

2.0 INFORMATION SUPPLIED WITH THE EQUIPMENT

2.1 Each item of equipment is supplied with a set of documentation which provides the information required for the safe installation and maintenance of the equipment. This may be in the form of a Data sheet and/or Installation and Maintenance instruction.
 2.2 Each unit has a rating plate attached to its outer casing. The rating plate provides essential data relating to the equipment such as serial number, unit code and electrical data. Any further data that may be required will be found in the documentation.
 If any item is unclear or more information is required, contact Nuaire.
 2.3 Where warning labels or notices are attached to the unit the instructions given must be adhered to.

3.0 TRANSPORTATION, HANDLING AND STORAGE

3.1 Care must be taken at all times to prevent damage to the equipment. Note that shock to the unit may result in the balance of the impeller being affected.
 3.2 When handling the equipment, care should be taken with corners and edges and that the weight distribution within the unit is considered. Lifting gear such as slings or ropes must be arranged so as not to bear on the casing.
 3.3 Equipment stored on site prior to installation should be protected from the weather and steps taken to prevent ingress of contaminants.

4.0 OPERATIONAL LIMITS

4.1 It is important that the specified operational limits for the equipment are adhered to e.g. operational air temperature, air borne contaminants and unit orientation.
 4.2 Where installation accessories are supplied with the specified equipment e.g. wall mounting brackets. They are to be used to support the equipment only.
 Other system components must have separate provision for support.
 4.3 Flanges and connection spigots are provided for the purpose of joining to duct work systems. They must not be used to support the ductwork.
 4.4 **Local Environment - Humidity.** Ambient humidity (the humidity at the unit's installed location) shall be within the range: 10 to 95% (for controls, non-condensing).
 Air humidity (the humidity of the air passing through the unit) shall be within the range: 10 to 95% (for controls, non-condensing).

5.0 INSTALLATION REQUIREMENTS

In addition to the particular requirements given for the individual product, the following general requirements should be noted.
 5.1 Where access to any part of equipment which moves, or can become electrically live are not prevented by the equipment panels or by fixed installation detail (e.g. ducting), then guarding to the appropriate standard must be fitted.
 5.2 The electrical installation of the equipment must comply with the requirements of the relevant local electrical safety regulations.
 5.3 For EMC all control and sensor cables should not be placed within 50mm or on the same metal cable tray as 230V switched live, lighting or power cables and any cables not intended for use with this product.

6.0 COMMISSIONING REQUIREMENTS

6.1 General pre-commissioning checks relevant to safe operation consist of the following:
 Ensure that no foreign bodies are present within the fan or casing.
 Check electrical safety e.g. Insulation and earthing.
 Check guarding of system.
 Check operation of Isolators/Controls.
 Check fastenings for security.
 Other commissioning requirements are given in the relevant product documentation.

7.0 OPERATIONAL REQUIREMENTS

7.1 Equipment access panels must be in place at all times during operation of the unit, and must be secured with the original fastenings.
 7.2 If failure of the equipment occurs or is suspected then it should be taken out of service until a competent person can effect repair or examination (Note that certain ranges of equipment are designed to detect and compensate for fan failure).

8.0 MAINTENANCE REQUIREMENTS

8.1 Specific maintenance requirements are given in the relevant product documentation.
 8.2 It is important that the correct tools are used for the various tasks required.
 8.3 If the access panels are to be removed for any reason the electrical supply to the unit must be isolated.
 8.4 A minimum period of two minutes should be allowed after electrical disconnection before access panels are removed. This will allow the impeller to come to rest.
NB: Care should still be taken however since airflow generated at some other point in the system can cause the impeller to "windmill" even when power is not present.
 8.5 Care should be taken when removing and storing access panels in windy conditions.



UK DECLARATION OF INCORPORATION AND INFORMATION FOR SAFE INSTALLATION, OPERATION AND MAINTENANCE

We declare that the machinery named below is intended to be assembled with other components to constitute a system of machinery. All parts except for moving parts requiring the correct installation of safety guards comply with the essential requirements of the Machinery Directive. The machinery shall not be put into service until the system has been declared to be in conformity with the provisions of the EC Machinery Directive.

Product: SHORT CASE AXIAL FAN
Type: SC
Relevant UK Council Directives: 2008 No. 1597, The Supply of Machinery (Safety) Regulations 2008;

Applied UK Harmonised Standards: BS EN 60204-1:2006+A1:2009+AC:2010; BS EN ISO 12100:2010; BS EN ISO 13857:2008; BS EN ISO 9001:2015

Signature of manufacture representatives:

Name:		Position:	Date:
1) A. Thomas		Technical Director	06. 08. 21
2) C. Sargent		Manufacturing Director	06. 08. 21

Basis of Self Attestation: BS EN ISO 9001, BSI Cert No. FM 665203

Nuaire: A Trading Division of Polypipe, Western Industrial Estate, Caerphilly, CF83 1NA.

All standards used were current and valid at the date of signature.

INFORMATION FOR SAFE INSTALLATION, OPERATION AND MAINTENANCE OF NUAIRE VENTILATION EQUIPMENT

To comply with UK Regulations: The Supply of Machinery (Safety) Regulations 2008 and Electromagnetic Compatibility Regulations 2016. To be read in conjunction with the relevant product documentation (see 2.1)

1.0 GENERAL

1.1 The equipment referred to in this Declaration of Incorporation is supplied by Nuaire to be assembled into a ventilation system which may or may not include additional components. The entire system must be considered for safety purposes and it is the responsibility of the installer to ensure that all of the equipment is installed in compliance with the manufacturers recommendations and with due regard to current legislation and codes of practice.

2.0 INFORMATION SUPPLIED WITH THE EQUIPMENT

2.1 Each item of equipment is supplied with a set of documentation which provides the information required for the safe installation and maintenance of the equipment. This may be in the form of a Data sheet and/or Installation and Maintenance instruction. Each unit has a rating plate attached to its outer casing. The rating plate provides essential data relating to the equipment such as serial number, unit code and electrical data. Any further data that may be required will be found in the documentation. If any item is unclear or more information is required, contact Nuaire.

2.2 Where warning labels or notices are attached to the unit the instructions given must be adhered to.

3.0 TRANSPORTATION, HANDLING AND STORAGE

3.1 Care must be taken at all times to prevent damage to the equipment. Note that shock to the unit may result in the balance of the impeller being affected.

3.2 When handling the equipment, care should be taken with corners and edges and that the weight distribution within the unit is considered. Lifting gear such as slings or ropes must be arranged so as not to bear on the casing.

3.3 Equipment stored on site prior to installation should be protected from the weather and steps taken to prevent ingress of contaminants.

4.0 OPERATIONAL LIMITS

4.1 It is important that the specified operational limits for the equipment are adhered to e.g. operational air temperature, air borne contaminants and unit orientation.

4.2 Where installation accessories are supplied with the specified equipment e.g. wall mounting brackets. They are to be used to support the equipment only. Other system components must have separate provision for support.

4.3 Flanges and connection spigots are provided for the purpose of joining to duct work systems. They must not be used to support the ductwork.

4.4 **Local Environment - Humidity.** Ambient humidity (the humidity at the unit's installed location) shall be within the range: 10 to 95% (for controls, non-condensing). Air humidity (the humidity of the air passing through the unit) shall be within the range: 10 to 95% (for controls, non-condensing).

5.0 INSTALLATION REQUIREMENTS

In addition to the particular requirements given for the individual product, the following general requirements should be noted.

5.1 Where access to any part of equipment which moves, or can become electrically live are not prevented by the equipment panels or by fixed installation detail (e.g. ducting), then guarding to the appropriate standard must be fitted.

5.2 The electrical installation of the equipment must comply with the requirements of the relevant local electrical safety regulations.

5.3 For EMC all control and sensor cables should not be placed within 50mm or on the same metal cable tray as 230V switched live, lighting or power cables and any cables not intended for use with this product.

6.0 COMMISSIONING REQUIREMENTS

6.1 General pre-commissioning checks relevant to safe operation consist of the following:
 Ensure that no foreign bodies are present within the fan or casing.
 Check electrical safety e.g. Insulation and earthing.
 Check guarding of system.
 Check operation of Isolators/Controls.
 Check fastenings for security.

6.2 Other commissioning requirements are given in the relevant product documentation.

7.0 OPERATIONAL REQUIREMENTS

7.1 Equipment access panels must be in place at all times during operation of the unit, and must be secured with the original fastenings.

7.2 If failure of the equipment occurs or is suspected then it should be taken out of service until a competent person can effect repair or examination (Note that certain ranges of equipment are designed to detect and compensate for fan failure).

8.0 MAINTENANCE REQUIREMENTS

8.1 Specific maintenance requirements are given in the relevant product documentation.

8.2 It is important that the correct tools are used for the various tasks required.

8.3 If the access panels are to be removed for any reason the electrical supply to the unit must be isolated.

8.4 A minimum period of two minutes should be allowed after electrical disconnection before access panels are removed. This will allow the impeller to come to rest.

NB: Care should still be taken however since airflow generated at some other point in the system can cause the impeller to "windmill" even when power is not present.

8.5 Care should be taken when removing and storing access panels in windy conditions.