



ecosmart
adapt

XBOXER XBC

UNIT SIZES 10 - 65 WITH
ECOSMART ADAPT (SIEMENS) CONTROL (AS)
INSTALLATION, OPERATING AND
MAINTENANCE INSTRUCTIONS



FOR THE COMPLETE VENTILATION SOLUTION



XBOXER XBC ECOSMART ADAPT (SIEMENS) CONTROL (AS)

CONTENTS - INSTALLATION, OPERATING & MAINTENANCE INSTRUCTIONS

	PAGE
1.0 Introduction	3
2.0 XBOXER XBC Unit Access Concepts	4
3.0 Delivery of Equipment	5
4.0 Erection and Assembly	5
5.0 Dimensions and Weights	6
6.0 Installing the XBC Fan Units and Attenuators	10
7.0 Commissioning and Setting To Work	14
8.0 Description Of Control - Software Strategy	16
9.0 Description Of Control - Touch Screen Ancillary	17
10.0 Electrical Details	18
11.0 Connection and Wiring Diagrams	21
12.0 Maintenance	32
13.0 Service Schedule	32
14.0 Warranty	32
15.0 After Sales Enquiries	32

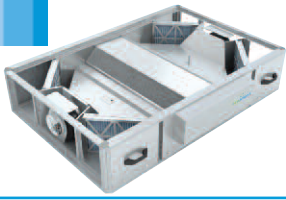

XBOXER XBC 10-65 (AS Control)



Supply & Extract Ventilation Unit with Heat Recovery Installation and Maintenance

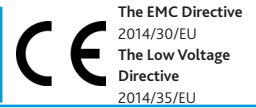

1.0 Introduction

The information contained in this document provides details of installation, operation and maintenance for installers and users of the XBOXER XBC Supply and Extract Ventilation Unit with Heat Recovery.

This supply and extract air handling unit range comprises an combination of high efficiency centrifugal fans with EC motors, a Counterflow design plate heat exchanger, filters, optional heaters (LPHW and Electric) and a casing with high mass acoustic treatment.

A range of matched, close coupled attenuators with a similar construction method to that of the unit is available. The attenuators can be flipped for positioning on the left or right of the fan unit (see Figure 1) allowing flexibility for duct layout.

Attenuators are available in 1050, 1250 and 1600mm lengths and a matching attenuator flange is attached to the fan unit.

General information regarding performance and specifications for the equipment may be obtained from our Technical Literature, and/or project specific documentation.

Figure 1. Layout Overview of the XBC unit viewed from above and shown with matched room side and atmospheric side attenuators. Access for maintenance and inspection of the standard XBOXER XBC units is from the side of the unit.

Code description: XBOXER XBC Ventilation Unit

XBC 45 - H - L - AS - WP - R - BA
 1 2 3 4 5 6 7 8

1. XBOXER XBC Range
2. Unit size 10, 15, 25, 45, 55 and 65
3. H = Horizontal Side by Side layout
4. N = No Heater
L = LPHW Heater
E = Electric Heater
5. AS = Adapt Control (Siemens)
6. WP = Separate Matched Weather Roof if required
7. R = Opposite arrangement (control box, heater battery and condensate pipe connection on opposite side)
8. BA = Bottom access (filter only, see section 2.0)
CP = Constant Pressure

Code description: Matched Combined Attenuator

XBC 25 - HS - MS10
 1 2 3 4

1. XBOXER XBC Range
2. Unit size 10, 15, 25, 45, 55 and 65
3. HS = Horizontal Supply/Discharge Attenuator
HE = Horizontal Extract/Intake Attenuator
4. MS10 = 1050mm Attenuator
MS12 = 1250mm Attenuator
MS16 = 1600mm Attenuator

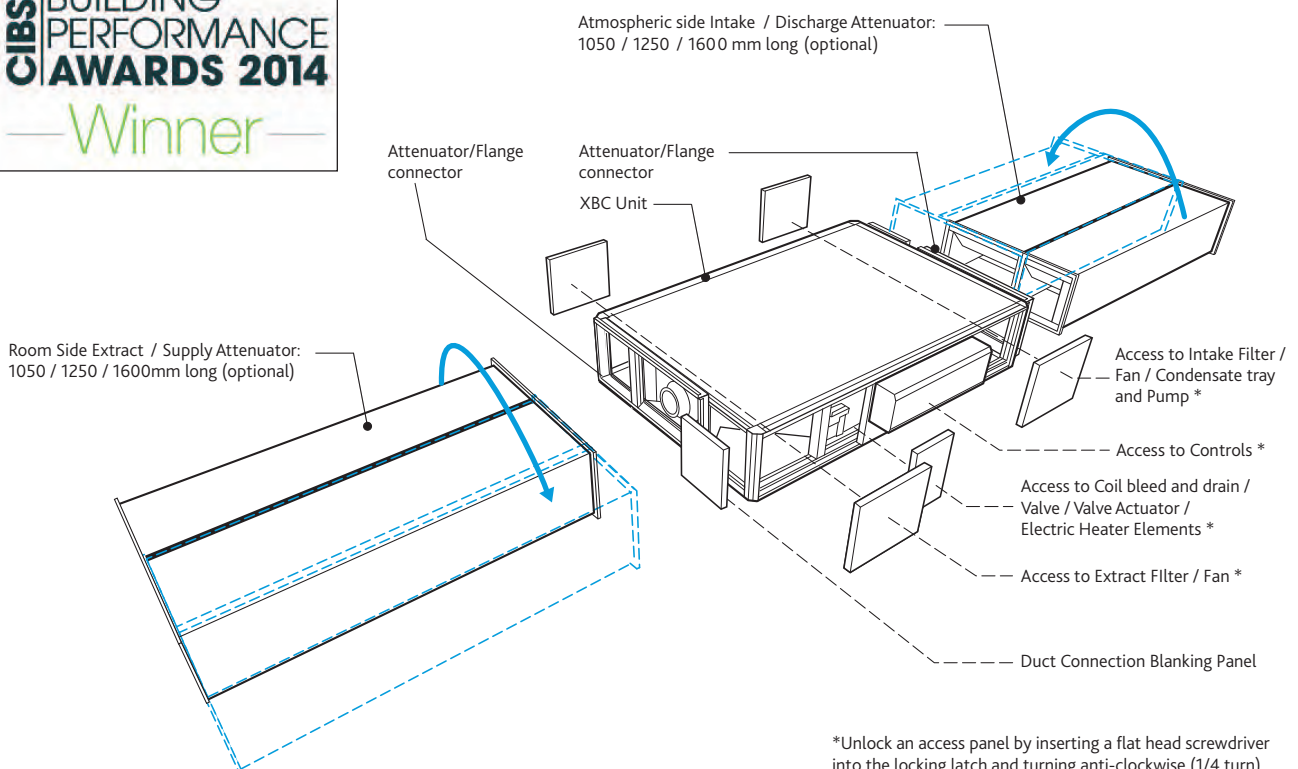

*Unlock an access panel by inserting a flat head screwdriver into the locking latch and turning anti-clockwise (1/4 turn).
Note: Bottom access unit (BA) Filters cannot be accessed from the side of the unit.

XBOXER XBC 10-65 Ecosmart Adapt (Siemens) Control (AS)

2.0 XBOXER XBC Unit Access Concepts

In this product range, several unique concepts have been implemented with a view to simplifying the installation design.

1. The unit configuration is such that the supply and discharge connections are positioned on the unit centre line. The corresponding Intake and Extract connections may be positioned on either side of the unit, allowing greater flexibility in the layout of ductwork in the space, (see Figure 3) with the blanking panel re-positioned to suit.
2. The standard Ecosmart XBC unit configuration is shown in Figure 4. **Unit handling information will not be requested for this range, and units will be supplied in this format as standard.**
3. The unit must be installed with at least 250mm clearance from a wall / barrier. With this absolute minimum clearance, the unit may be connected to the power supply and control connections since the control may be rotated by 90 degrees to face downwards. **(Note: - cable connections must allow for the relative movement when the control is re-positioned).**
4. With this clearance, unit filters may be changed, and the fans coils, heat exchanger and condensate tray may be inspected and cleaned if necessary.
5. The LPHW and Electrical heater settings, coil bleed and drain, and all other control adjustments are similarly accessible (see Figure 1).
6. Side access, where possible, is preferred in all cases in terms of safe working access to the equipment under the CDM regulations.
7. Note however, that access in the situation is difficult and does not allow for major maintenance including component replacement. Nuair recommend as best practice guidance, to allow for a minimum of around 600mm clearance (as stated in ADF 2010).
8. Where these arrangements are not suitable, the Consultant's and Contractor's project specific requirements will always be accommodated where possible.

9. Bottom access only units (Example code: XBC15-H-LES BA), provide access to filters only (see fig 6).

Filter removal is not available from the sides on these units. Bottom access units must be installed with the following minimum clearance below the units. XBC15 = 225mm, XBC25 = 300mm XBC45 = 360mm.

Note: Bottom access is not available on XBC55 or XBC65 units.

Figure 2. The control side of the unit must be installed with at least 250mm clearance from a wall / barrier to gain access from the side.

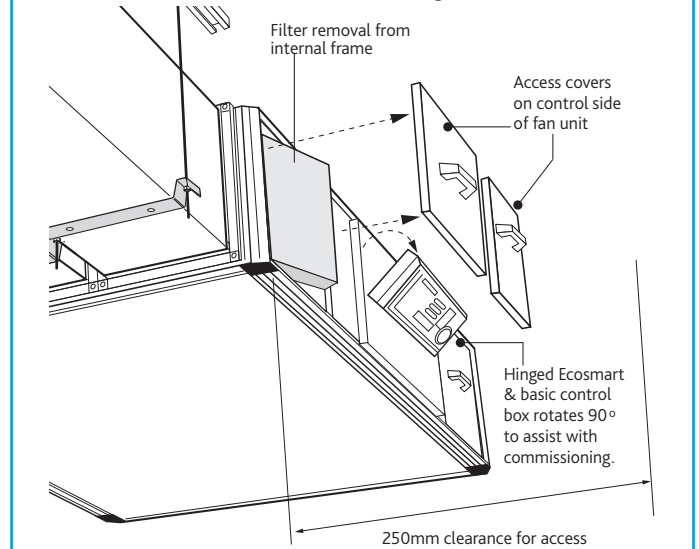

IMPORTANT

Unlocking an access panel is achieved by inserting a flat head screwdriver into the locking latch groove and turning anti-clockwise (1/4 turn), keys are neither required nor provided by Nuair.

Figure 3. Selectable Duct Connections (Top view).

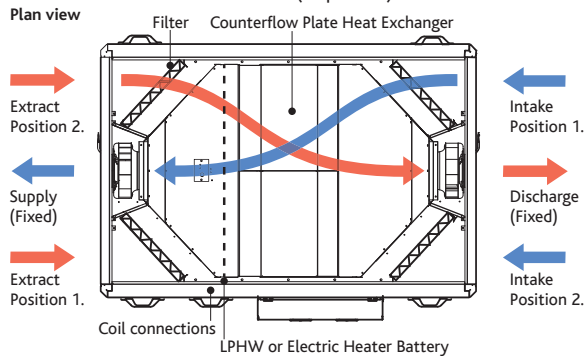

Note: The unit is shipped with four G4 filters in place, two of which are included as spares. For F7 filters contact Nuair.

Figure 5. Opposite unit arrangement (R) side access (Top view).

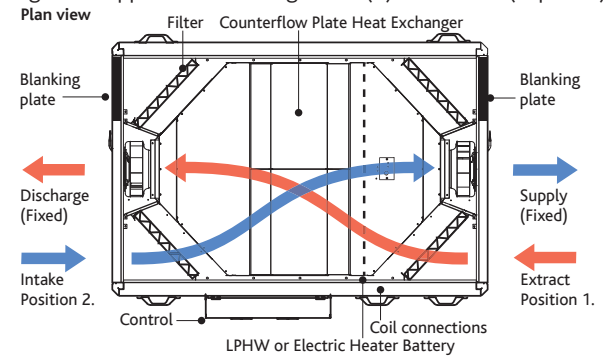

Figure 4. Standard Unit Format (Top view).

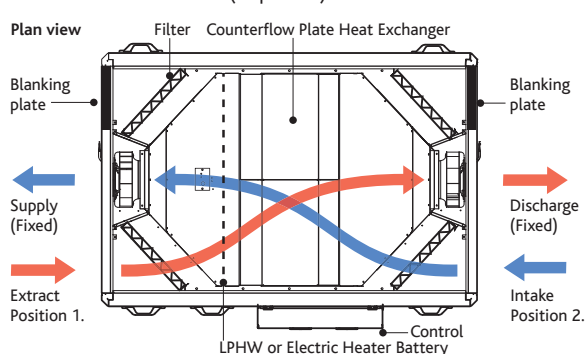
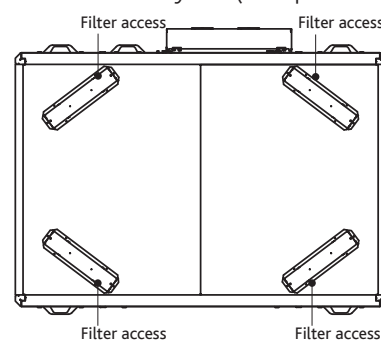

Figure 6. Bottom access only unit (Example code: XBC15-H-LAS-BA).



XBOXER XBC 10-65 Ecosmart Adapt (Siemens) Control (AS)

IMPORTANT

Safety first! – Before commencing any work ensure:

- That all appropriate risk assessments have been carried out and the required safety measures have been taken.
- That you understand the work required.
- That you are trained and competent to carry it out.

3.0 Delivery of Equipment

3.1 Receipt of equipment

All equipment is inspected prior to despatch and leaves the factory in good condition. Upon receipt of the equipment an inspection should be made and any damage indicated on the delivery note.

Particulars of damage and/or incomplete delivery should be endorsed by the driver delivering the goods before offloading by the purchaser.

No responsibility will be accepted for damage sustained during the offloading from the vehicle or on the site thereafter.

All claims for damage and/or incomplete delivery must be reported to Nuair within two days of receipt of the equipment.

3.2 Offloading and Handling from the delivery Vehicle

The weight of the unit modules and palletised items is displayed on the unit rating plate or on the packaging. Some of the modules have an uneven weight distribution, and this will be indicated by labelling where appropriate. Ensure that lifting and handling equipment is adequately rated.

Offloading and positioning of the equipment is the responsibility of the purchaser.

Spreaders should be used when lifting with slings to avoid damage to the casings. Care must be taken to ensure that slings are correctly positioned to avoid crushing and twisting of the unit castings.

Where channels and/or support frames are bolted to the underside of the unit casing, slings or fork-lift arms should be positioned to locate in the apertures in the channels. If Lifting Eyes have been supplied / fitted it is recommended that they are used.

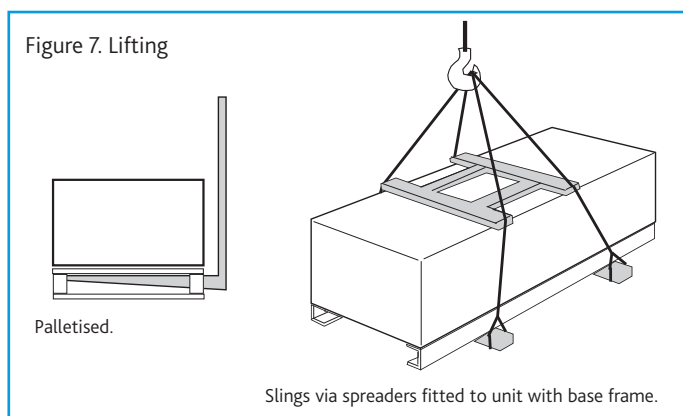

XBOXER XBC unit sections will be delivered to site in one section.

Each Section will be labelled with the direction of air flow.

The direction convention must be observed during assembly.

The unit may only be operated in its intended horizontal installation plane.

The unit must be fully levelled during installation (this is essential to ensure that condensate drains correctly).

See page 4 for dimensions and weights.

3.3 Storage

The equipment must be stored in a dry, internal location. Ductwork connection apertures shall be sealed against the ingress of dust, water and vermin.

If the storage period is to exceed two months, contact Nuair for guidance on the appropriate "mothballing" procedures.

Do not stack units, modules or components.

4.0 Erection and Assembly

Units must be installed in accordance with good industry practice.

These units may only be mounted horizontally and must be fully levelled in the horizontal plane. The units are heavy, and should be mounted using the fixing brackets supplied or other suitable methods of support. The supporting structure must be assessed for structural suitability.

Heat recovery components and modules that incorporate cooling coils may produce condensation during use. An insulated drip tray and condensate pump is provided. The drain connection must be connected to a suitable drainage point (see Figure 21 on page 14 for details).

4.1 Condensate Pump Alarm

The condensate pump incorporates an alarm function. If the water level in the condensate tray exceeds a maximum level (for example, as a result of the discharge tube becoming blocked or frozen), the alarm contact will open. This contact is internally connected to the heat exchanger bypass actuator, and the unit will automatically be placed into bypass mode, preventing further condensate production. Unit operation will otherwise be unaffected.

Condensate pump specification

Maximum flow rate = 12 l/h

Maximum head = 20m Vertical, 100m Horizontal

Pipe Connection size (Condensate) XBOXER XBC = 8 mm

LPHW Coils, if fitted, are tested during manufacture to 16 Bar (using dry compressed air). Coil and valve assemblies are similarly tested to 10 Bar. Operation of standard equipment is rated at PN6, if the intended system requires higher operating pressures; please contact the Nuair Technical department for advice.

Electrical connections to the unit shall be made in accordance with the appropriate product (see below); and installation wiring diagrams, and shall use appropriately sized and rated cables.

Only the prepared apertures in the unit casing may be used for cable entry. Do not drill or cut the unit casing for this purpose. Cable access points are provided at the ends of the control enclosure.

If the control is rotated to aid connection of cables, please ensure that sufficient flexibility is provided in the final connection run.

N.B. To avoid conflict with the unit access panels, it is recommended that electrical and plumbing service connections to the unit are run at 90 degrees to the main air flow axis.

Control circuit connections must be segregated (i.e. routed separately) from power connections.

The unit rating label shows the maximum electrical load of the equipment. Connections to the unit may include single phase supply connections, and a variety of control circuits.

Only the prepared apertures in the unit casing may be used for cable entry. Do not drill or cut the unit casing for this purpose.

The equipment must be earthed and earth-bonded. Means of local isolation for maintenance purposes are generally required (by others). Ensure that all mains connections are isolated.

XBOXER XBC 10-65 Ecosmart Adapt (Siemens) Control (AS)

5.0 Dimensions and Weights

5.1 XBOXER XBC (ES and BC) Unit Dimensions (mm) and Weights (kg)

Figure 8. Standard unit dimensions (mm) and weights (kg).

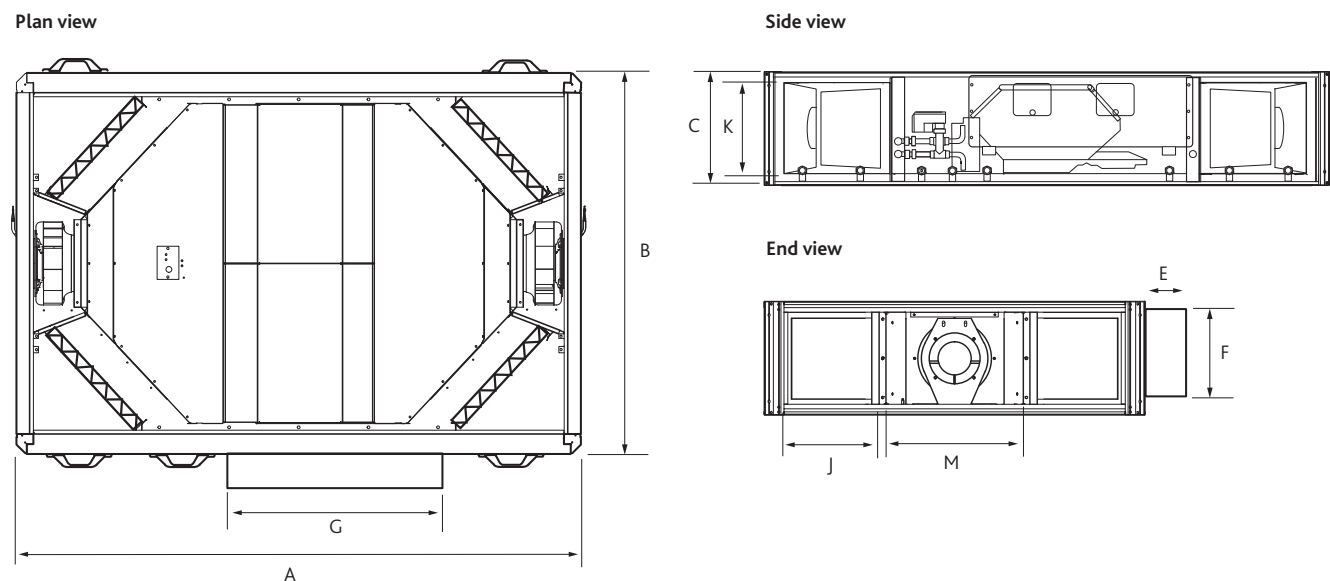

Unit Code	Unit Dimensions (mm)						Control Dimensions (mm)			Unit Weights	Packed Weights
*	A	B	C	J	K	M	E	F	G	(kg)	(kg)
XBC10-H-*AS	1600	1000	260	238	220	347	120	200	670	145	195
XBC15-H-*AS	1600	1000	260	238	220	347	120	200	670	195	245
XBC25-H-*AS	1700	1150	340	252	302	471	120	200	670	242	292
XBC45-H-*AS	1900	1250	400	270	360	531	120	200	670	298	398
XBC55-H-*AS	1900	1560	470	398	430	588	120	200	670	368	418
XBC65-H-*AS	1900	1560	620	398	580	588	120	200	670	476	626

2 attenuator flange connections are attached to every unit. Add 50mm to dimension 'A' to include both flanges.

* Type of heater battery.

Weatherproof Dimension Changes (mm)									
*	A	B	C	J	K	M	E	F	G
Weatherproof	Add	Add	Add	No change	No change	No change	Add	Equal to	Add
Unit Size Increase	470	260	100	No change	No change	No change	130	Dim C	400

Size increases are approximate and may vary depending on model.

5.2 XBOXER XBC Unit Hanging Bracket Positions

Figure 9. Plan view of unit with 4 hanging brackets attached (two each side of the unit).

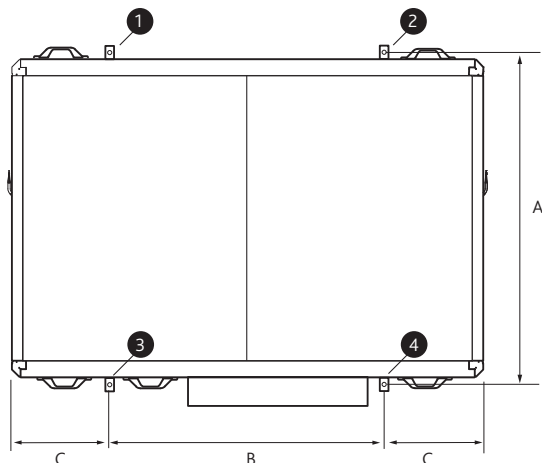

Unit Code	Dimensions to Hole Centres (mm)		
	A	B	C
XBC10-H-LES	1059	858	371
XBC15-H-LES	1059	858	371
XBC25-H-NBC	1207	888	406
XBC45-H-NBC	1309	1008	446
XBC55-H-NBC	1619	1058	421
XBC65-H-NBC	1619	1058	421

Compatible with 20mm Mez.

XBOXER XBC 10-65 Ecosmart Adapt (Siemens) Control (AS)

5.3 XBOXER XBC Attenuator Flange Connector Dimensions (mm)

Figure 10. Attenuator flange connector dimensions.

XBC10 & 15 Flange Connector

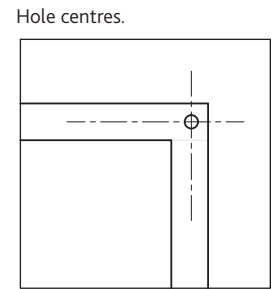
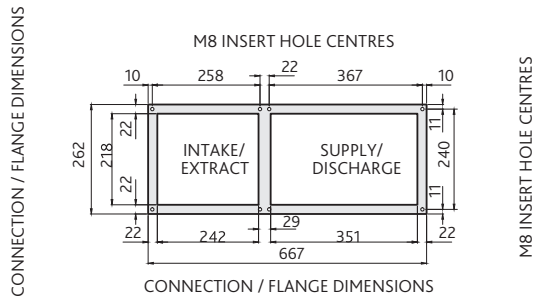

Compatible with 20mm Mez.

XBC25 Flange Connector

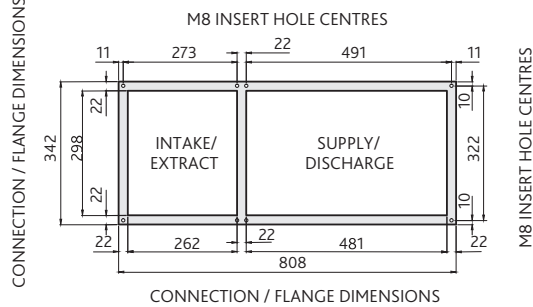

XBC45 Flange Connector

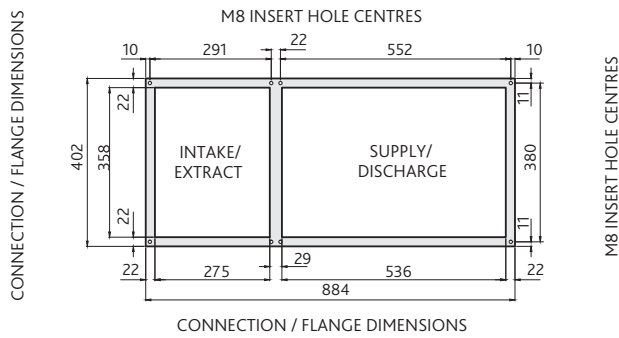

XBC55 Flange Connector

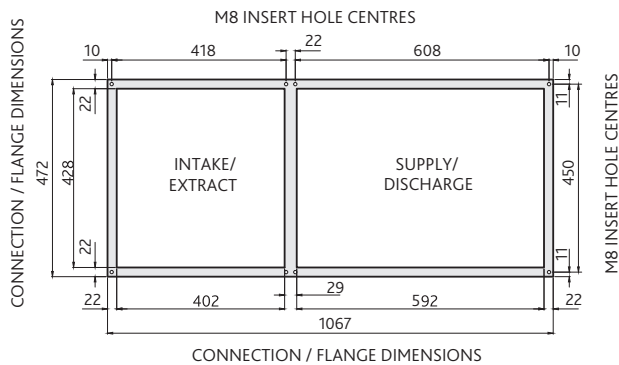

XBC65 Flange Connector

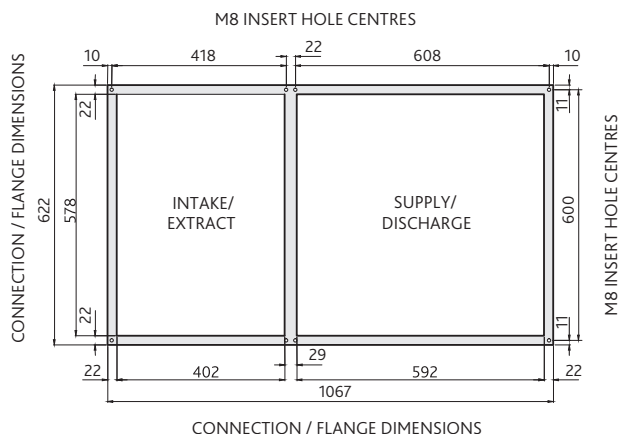

Note: The flange connector leaves factory attached to unit.

XBOXER XBC 10-65 Ecosmart Adapt (Siemens) Control (AS)

5.4 XBOXER XBC Attenuator Dimensions (mm) and Weights (kg)

Figure 11. Attenuator dimensions (mm).

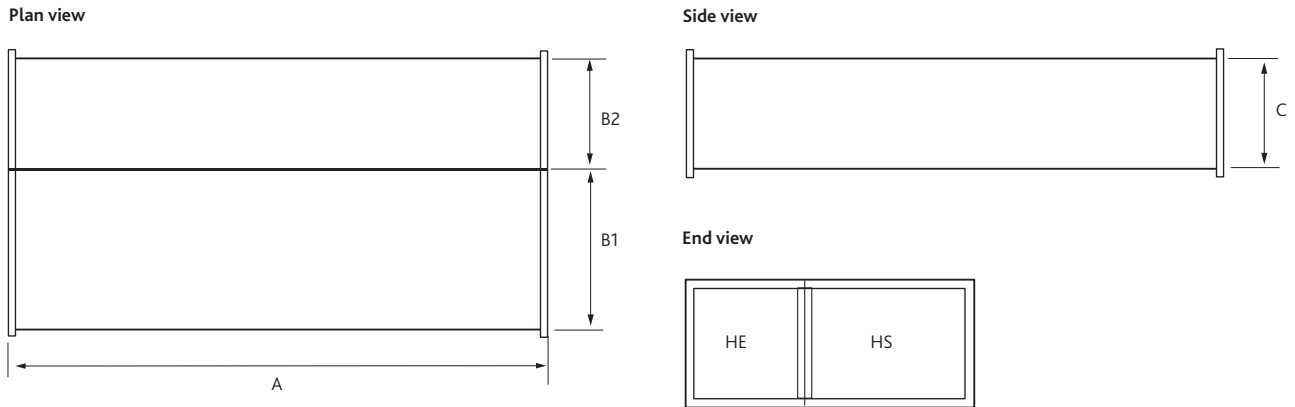

Attenuator Code	Dimensions (mm)				Attenuator Weights (kg)
	A	B1	B2	C	
XBC15-HS-MS10*	1050	347		220	30
XBC15-HE-MS10*	1050		238	220	24
XBC15-HS-MS12*	1250	347		220	35
XBC15-HE-MS12*	1250		238	220	29
XBC15-HS-MS16*	1600	347		220	44
XBC15-HE-MS16*	1600		238	220	36
XBC25-HS-MS10*	1050	471		302	29
XBC25-HE-MS10*	1050		252	302	29
XBC25-HS-MS12*	1250	471		302	34
XBC25-HE-MS12*	1250		252	302	34
XBC25-HS-MS16*	1600	471		302	42
XBC25-HE-MS16*	1600		252	302	42
XBC45-HS-MS10*	1050	531		360	32
XBC45-HE-MS10*	1050		270	360	32
XBC45-HS-MS12*	1250	531		360	40
XBC45-HE-MS12*	1250		270	360	37
XBC45-HS-MS16*	1600	531		360	47
XBC45-HE-MS16*	1600		270	360	47
XBC55-HS-MS10*	1050	588		430	32
XBC55-HE-MS10*	1050		398	430	36
XBC55-HS-MS12*	1250	588		430	37
XBC55-HE-MS12*	1250		398	430	42
XBC55-HS-MS16*	1600	588		430	47
XBC55-HE-MS16*	1600		398	430	52
XBC65-HS-MS10*	1050	588		580	43
XBC65-HE-MS10*	1050		398	580	46
XBC65-HS-MS12*	1250	588		580	51
XBC65-HE-MS12*	1250		398	580	54
XBC65-HS-MS16*	1600	588		580	63
XBC65-HE-MS16*	1600		398	580	67

2 attenuator flange connections are attached to every unit. Add 50mm to dimension 'A' to include both flanges.

XBOXER XBC 10-65 Ecosmart Adapt (Siemens) Control (AS)

5.5 XBOXER XBC Bend Attenuator Dimensions (mm) and Weights (kg)

Figure 12. Bend attenuator dimensions (mm).

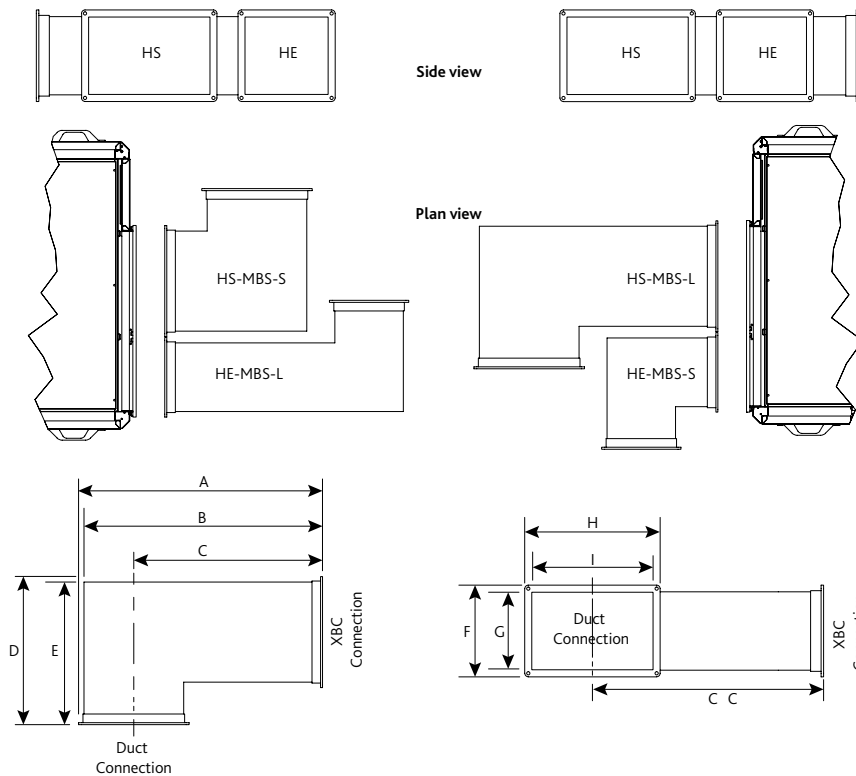

Attenuator Code	Unit Dimensions (mm)									Attenuator Weights (kg)
	A	B	C	D	E	F	G	H	I	
XBC15-HS-MBS-S*	515	496	322	515	496	260	220	386	346	20
XBC15-HS-MBS-L*	852	833	659	515	496	260	220	386	346	29
XBC15-HE-MBS-S*	406	387	268	406	387	260	220	277	237	14
XBC15-HE-MBS-L*	852	833	714	406	387	260	220	277	237	23
XBC25-HS-MBS-S	640	621	385	640	621	342	302	511	471	32
XBC25-HS-MBS-L	992	973	737	640	621	342	302	511	471	44
XBC25-HE-MBS-S	421	402	275	421	402	342	302	292	252	17
XBC25-HE-MBS-L	992	973	846	421	402	342	302	292	252	32
XBC45-HS-MBS-S	700	681	415	700	681	400	360	571	531	39
XBC45-HS-MBS-L	1070	1051	785	700	681	400	360	571	531	55
XBC45-HE-MBS-S	439	420	284	439	420	400	360	310	270	19
XBC45-HE-MBS-L	1070	1051	915	439	420	400	360	310	270	38
XBC55-HS-MBS-S	756	737	443	756	737	470	430	627	587	48
XBC55-HS-MBS-L	1253	1234	940	756	737	470	430	627	587	72
XBC55-HE-MBS-S	566	547	348	566	547	470	430	437	397	31
XBC55-HE-MBS-L	1253	1234	1035	566	547	470	430	437	397	58
XBC65-HS-MBS-S	756	737	443	756	737	620	580	627	587	54
XBC65-HS-MBS-L	1253	1234	940	756	737	620	580	627	587	82
XBC65-HE-MBS-S	566	547	348	566	547	620	580	437	397	36
XBC65-HE-MBS-L	1253	1234	1035	566	547	620	580	437	397	68

Coding:

HS - Denotes the type of silencer required for the supply or discharge.

HE - Denotes the type of silencer required for the extract or intake.

*Note: XBC15 silencers are also suitable for XBC10 units.

XBOXER XBC 10-65 Ecosmart Adapt (Siemens) Control (AS)

6.0 Installing the XBC Fan Units and Attenuators

The ventilation unit must be installed first—with consideration made for the length of the associated attenuators.

Installation of the XBOXER XBC units, including all external services and controls should be installed in accordance with the appropriate site procedures, and MUST conform to all governing regulations e.g. CDM, CIBSE, IEE, and in strict accordance with the applicable Building Regulations.

The correct installation position for the units shall be decided with due regard to access and maintenance requirements, and the objective of minimising the system ductwork resistance.

The recommended installation method is to use standard Unistrut channel secured to the slab / steelwork above the unit.

Four suitable drop rods should be secured to the Unistrut channel and extended to be fixed to the unit's four mounting brackets, (two each side of the fan unit) or to other horizontal supports by others where wider load distribution is required.

6.1 Installing the Attenuators

It is recommended that additional Unistrut channels are used to support the matched attenuators. M8 Drop rods should be secured to the Unistrut channel and extended to be fixed to the four piece support brackets to be used on the underside of the attenuators (see fig 14).

Note – once the attenuators are supported and levelled, and immediately before securing the attenuator to the attenuator flange connector, remove the backing from the Foam Sealing Strip.

The attenuators must be secured to the unit using the screws provided.

Figure 13. Installing the fan unit.

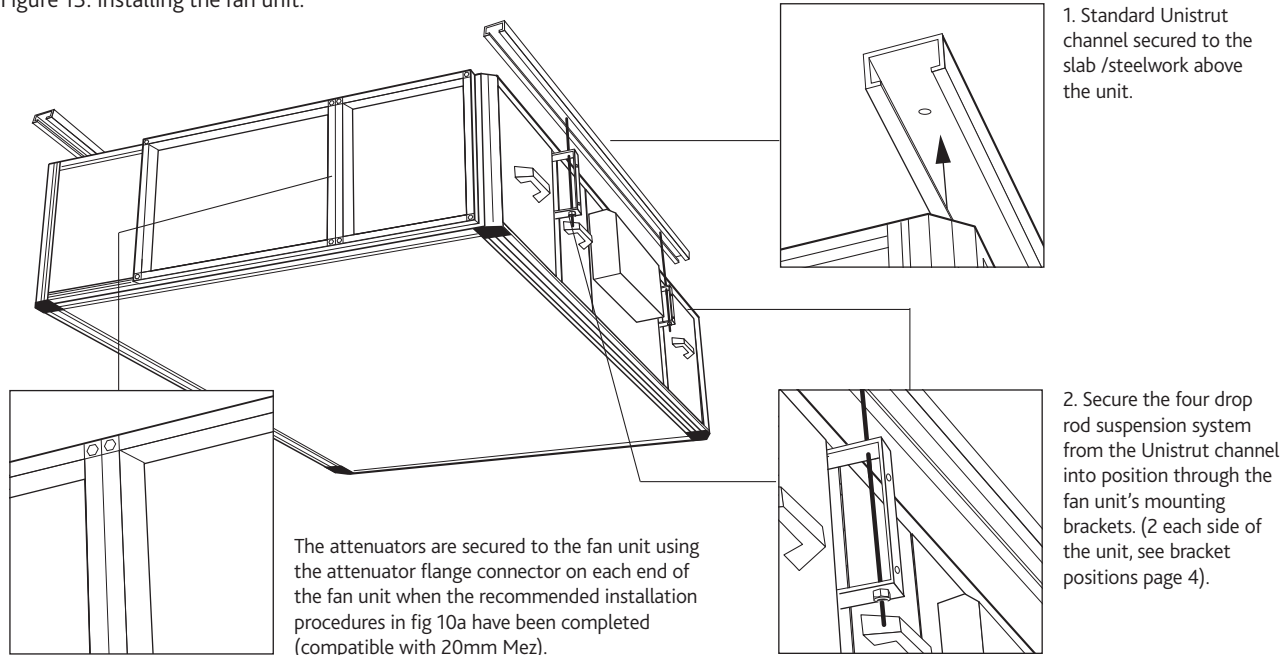
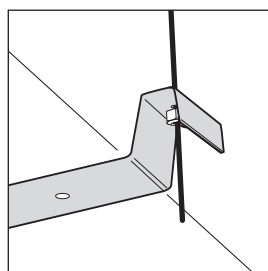
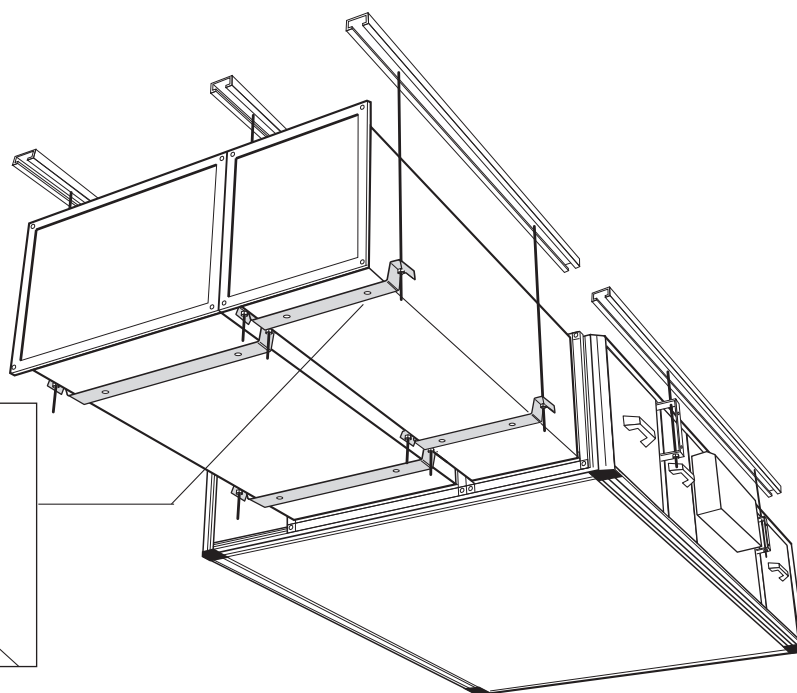

Figure 14. Installing the unit attenuators.

1. Secure standard Unistrut channel to the slab/ steelwork above the attenuators.
2. Secure M8 drop rods from the Unistrut channel into position.
3. Raise up the attenuator into position and attach the four piece support brackets onto the drop rods. (2 on each attenuator).
4. Utilising the 2 x 5.6mm dia holes in each bracket use relevant self tapping screws to fix into position on the underside of the attenuators.
5. Immediately before securing the attenuator to the connector, remove the backing from the Foam Sealing Strip.
6. Secure the attenuators to the attenuator flange connector on the end of the fan unit. (see fig 10).



Four piece support brackets.



XBOXER XBC 10-65 Ecosmart Adapt (Siemens) Control (AS)

6.2 Installing the XBC Weatherproof Roof on Ecosmart (ES) and Basic Control Fan Units (BC)

Having installed the ventilation unit and attenuators, the Weatherproof Roof can now be installed if required.

The Roof assembly and control cover must be secured to the unit using the fixing channel provided.

When the roof has been installed onto the fan unit please ensure that the edges of the roof are fully sealed where it joins the fan unit. This does not apply to the control cover as this will have to be removed if necessary.

Weatherproof Components

Item	Description	Quantity
A	Roof Assembly	1
B	Control Cover	1
C	Fixing Channel	

Optional Exhaust and Inlet Terminals

Item	Description	Quantity
D	Exhaust RT	1
E	Inlet RT	1

Unit Codes for Optional Exhaust and Inlet Terminals

XBC10-EXHAUST-RT
XBC10-INTAKE-RT
XBC15-EXHAUST-RT
XBC15-INTAKE-RT
XBC25-EXHAUST-RT
XBC25-INTAKE-RT
XBC45-EXHAUST-RT
XBC45-INTAKE-RT
XBC55-EXHAUST-RT
XBC55-INTAKE-RT
XBC65-EXHAUST-RT
XBC65-INTAKE-RT

Figure 15. Installing the weatherproof roof, exhaust and intake terminals.

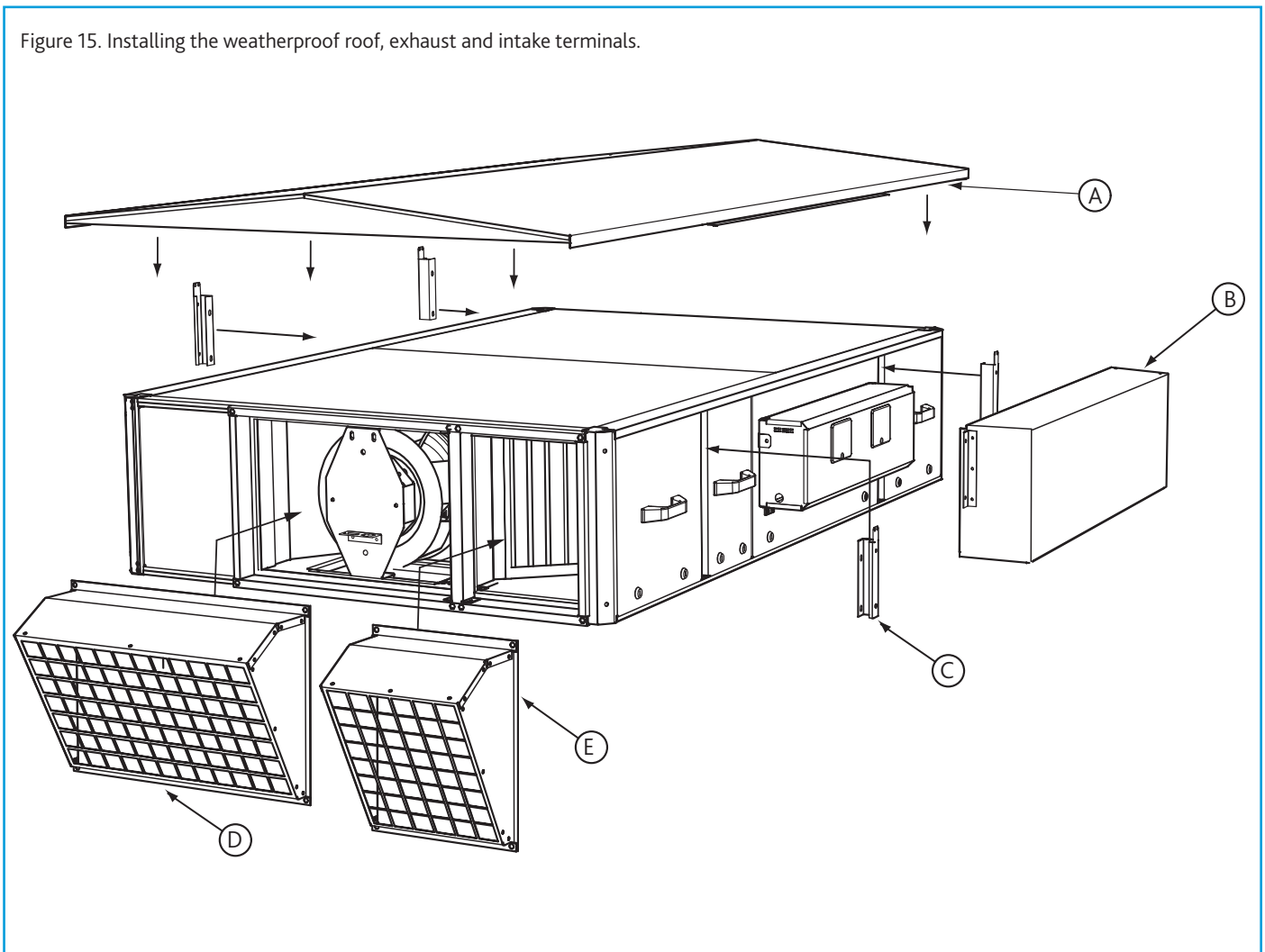

XBOXER XBC 10-65 Ecosmart Adapt (Siemens) Control (AS)

6.3 XBC Motorised Dampers

Internal version (example: XBC15-MD-AS).

External weather proof version (example: XBC15-MD-AS-WP).

If matching length Nuaire silencers (example codes: XBC15-HS-MS16 & XBC15-HE-MS16) are being fitted to the fan unit, the motorised damper (example code XBC15-MD-AS) should be fitted after the silencers (as Figure 16). This ensures that breakout noise levels are kept to a minimum.

Where unmatched silencers are being fitted to the fan unit, the motorised damper should be fitted before the silencers.

The motorised damper units will be supplied loose and are designed to fit directly onto the flange connector (by others).

- Fully interlocking parallel blades, half inch diameter electroplated mild steel spindle.
- Nylatron bushes and external nylon/aluminium blade interconnection linkage.
- Fitted with Belimo SM230A-S drive open/drive close actuator complete with switch.
- Motorised damper wiring will require connection on site and possible extension of the cable looms.

6.5 Constant Pressure Range (CP) - Controlling Static Pressure at Fan Inlet

Ecosmart constant pressure extract fans are supplied to control the static pressure at the fan inlet.

This set up is suitable for the majority of applications. When ancillaries with high pressure losses are fitted to the inlet side of the fan, the low pressure tapping must be moved from the fan chamber to a location upstream of the ancillaries, as shown below in Figure 17.

Failure to do this will result in excessive pressure being applied to the dampers at the rooms when the system is running in trickle mode.

Figure 16. Motorised damper installation options.

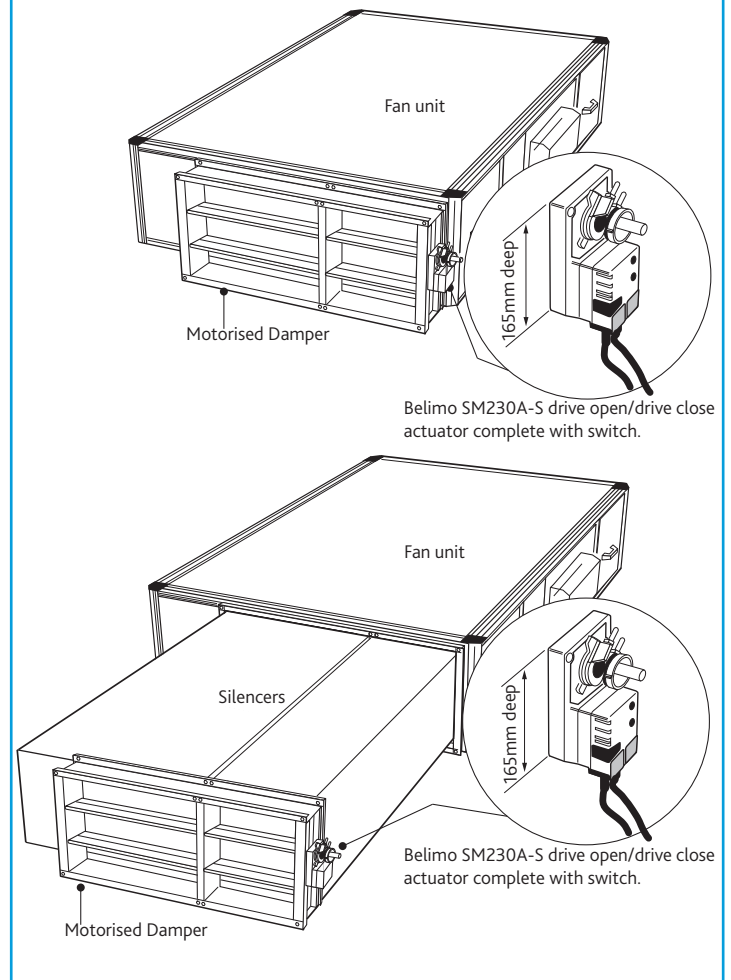
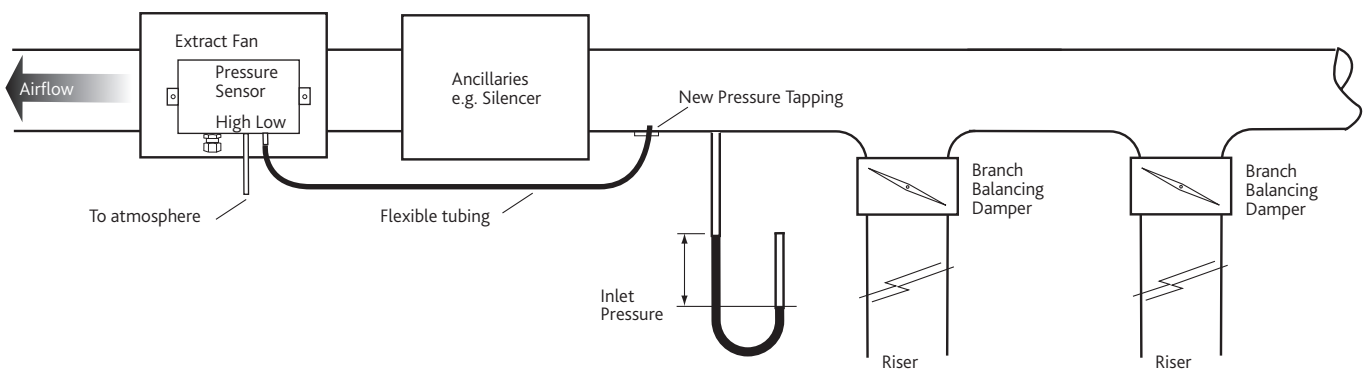

Figure 17. Constant pressure tapping locations.



6.4 Dirty Filter Pressure Switch

XBC units come with pre fitted pressure tappings for use with the dirty filter alarms (supplied loose) on both the supply and extract airstreams. The IP54 pressure switch is equipped with a red visual LED alarm which will illuminate when the pressure reading surpasses that set by the adjustable knob.

6.4.1 Mounting the Switches

Using the four mounting lugs provided, mount the pressure switches to a flat vertical surface using fixings appropriate for the surface. Any fixings used must have a maximum diameter of 8.0 mm. Do not tighten the fixings so much that the base of the device is deformed.

6.4.2 Connecting Pressure Tubing

IMPORTANT

Pressure tubing must not be kinked. Pay particular attention to this point if running hoses over an edge, it is better to form a loop.

For connection to the pressure switch, two fittings inherent in the housing are provided for hoses with an internal diameter of 6.0 mm.

- Connect a hose from the after filter (AF) pressure tapping to socket P1 which is located on the lower section of the housing.

XBOXER XBC 10-65 Ecosmart Adapt (Siemens) Control (AS)

- Connect a hose from the before filter (BF) pressure tapping to socket P2 which is located on the middle section of the housing.

After you have installed the hoses, it is absolutely essential to check them for tightness of fit at the connection points and to make sure that they run without any kinks.

6.5.1 Wiring

The cable gland is designed for cables with alternative sheath diameters of 7 mm or 10 mm. Only use these sizes. Otherwise the screw cable connection cannot seal adequately. The connections are intended for crimp-type sockets, 6.3 mm.

- Remove switch cover.
- Wire the main unit to the terminal block within the switch as per the below wiring diagrams (see Figure 1) ensuring the feed line is fused to suit Max 1.5A / 250 Vac.
- Refit switch cover.

6.5.2 Setting Switch Pressure

Make absolutely certain that there is no voltage on the electrical connections before you carry out any setting on the pressure switch, there is the possibility of an electric shock if you accidentally touch live parts.

Nuaires recommend the pressure switch be set to trigger when the filters experience a 125 Pa increase above the clean filter resistance for the largest commissioned airflow rate. Use the adjustment dial to set the pressure at which the switch will trip. When the pressure falls below this set value, the switch returns to its resting position.

Figure 18. Dirty filter switch wiring.

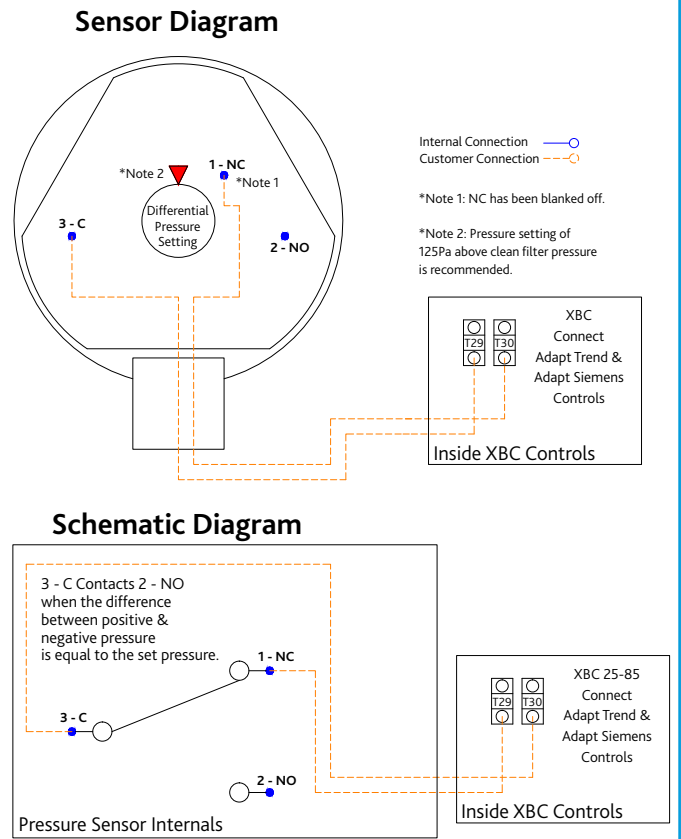

Figure 19. Access side view of pressure tapping layout of units with standard handing.

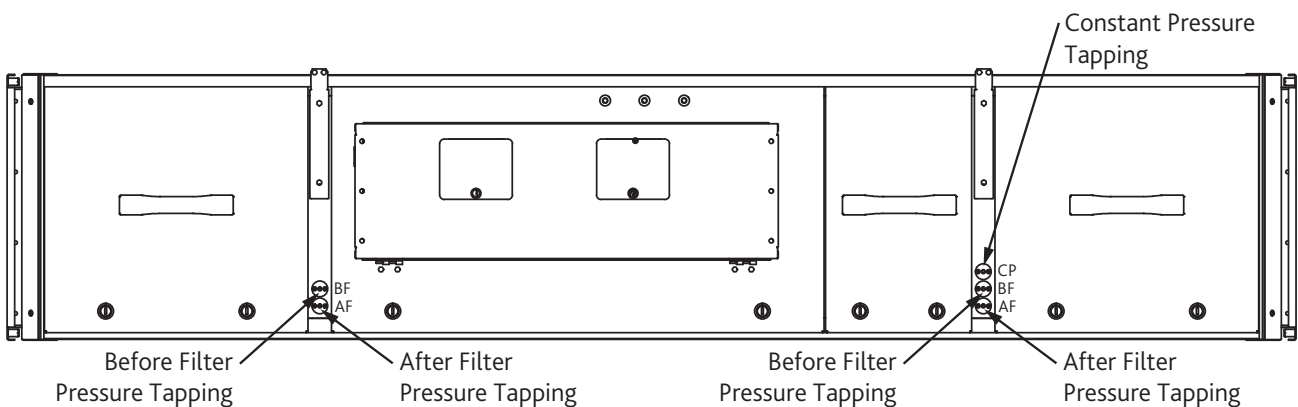
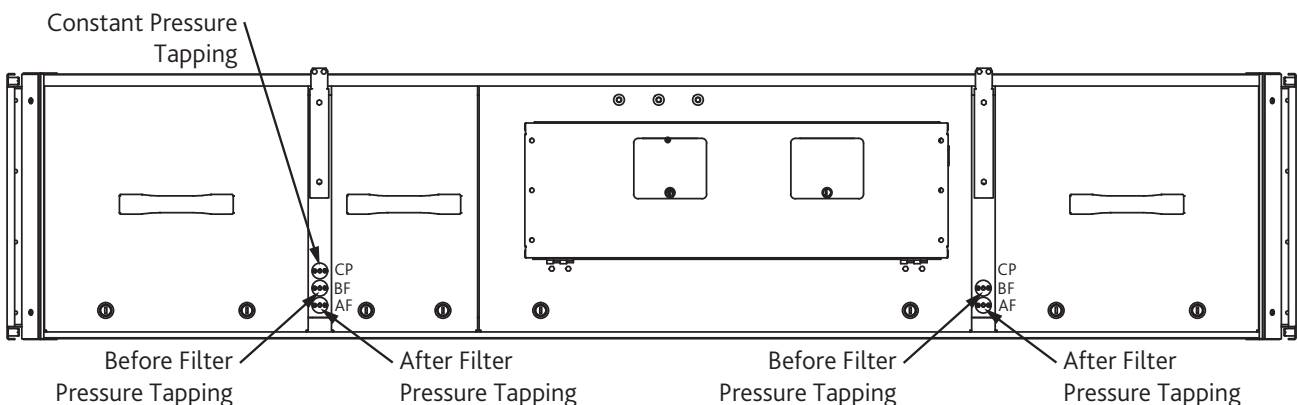
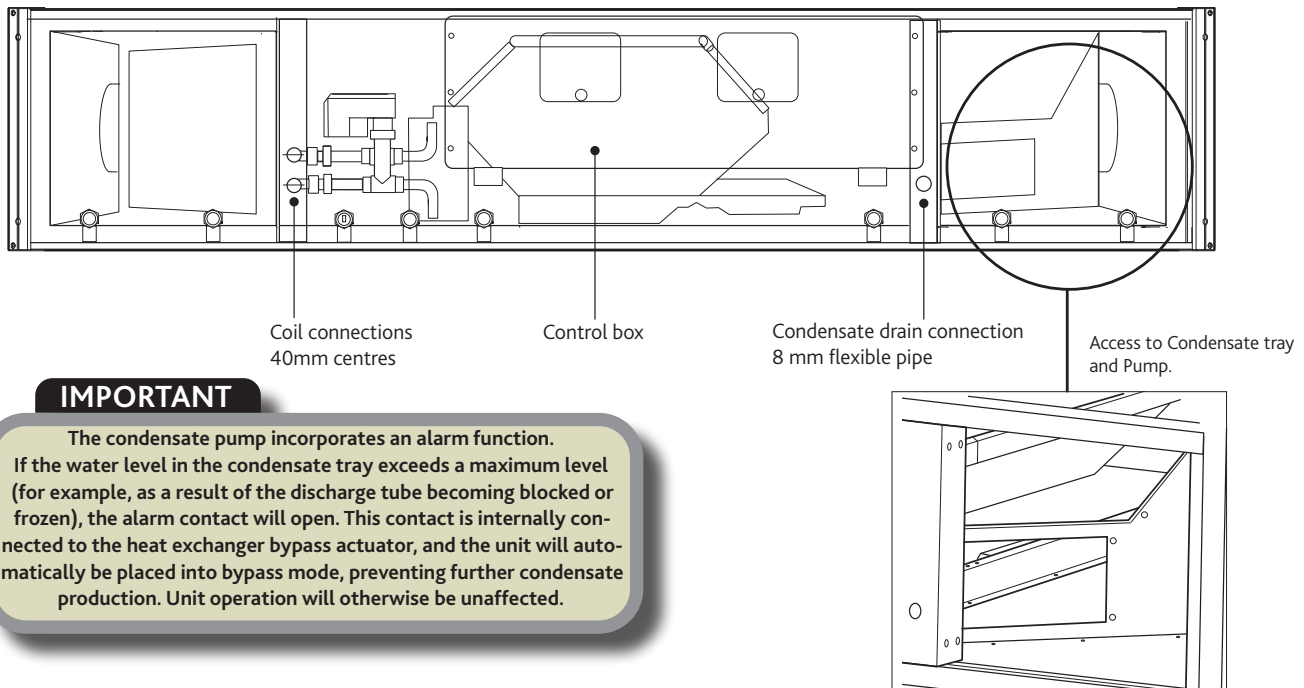

Figure 20. Access side view of pressure tapping layout of units with opposite handing.



XBOXER XBC 10-65 Ecosmart Adapt (Siemens) Control (AS)

Figure 21. Control side of unit showing coil and condensate connections.



7.0 Commissioning and Setting To Work

(Note – not all of the components listed here are necessarily included with the equipment supplied).

7.1 Filters

Remove filter access panels (observe and note airflow direction labels), inspect filters for contamination with construction debris, replace as necessary. Replace access panels.

Filter pressure drops will depend on actual flow rate and condition. Observe and record filter pressure drops after performance commissioning. Typically, filter “dirty” condition occurs when the initial filter “clean” readings have been increased by 125Pa.

If filter manometers, pressure switches or indicators have been fitted, they should be set or adjusted to reflect the commissioned system operation.

7.2 Heating Coils LPHW

Observe the Flow and Return connection labels on the unit. Drain and bleed valves are located on the coil (see fig 19). Other valves may be required in the system pipe-work depending on the installation (by others).

Where the wet system is at risk of frost damage, the addition of a proprietary anti-freeze solution to the water is recommended. Note that any frost protection offered by the unit’s integral control system will not operate if the power supply to the unit is interrupted.

Ecosmart frost protection is activated on any Ecosmart unit fitted with LPHW heating, when the outlet air temperature is 4°C or below. The unit reacts by shutting down the fan to prevent a ‘wind chill’ effect reducing the temperature to a point whereby the coil could freeze and burst. The unit will also drive open the LPHW valve to a fully open position to allow full water flow through the coil and the main PCB will close the ‘Heat demand’ contacts. These contacts could be used to send a signal to activate the boiler and/or valve to open to provide heat if not already doing so.

Piped connections should be made to the unit using appropriate techniques, and all pipework must be independently supported. No hot work is permitted within one metre of the unit.

Ensure that installed pipework runs do not prevent or restrict access to the unit at any point.

The completed installation (including the connections within the unit, as these may be disturbed during installation) shall be pressure tested to the project engineer’s specification (**This is a condition of the unit warranty**).

7.3 Fan Sections

Access to the fan section is via lift off panels (see Figure 1 & Figure 21).

For non-Ecosmart units, wiring to the fan motor / unit terminal box should be mechanically protected and in made in accordance with the details on the motor name plate and diagram attached to the unit.

With the unit electrically isolated, rotate the fan impeller / drive manually, checking that it spins freely.

Check all fixings are secure.

Units must not be operated without all access panels in place – damage to equipment or injury to personnel may result. Units must not be operated unless control interlocks are in place – damage to equipment may result.

Test run motor for condition and correct rotation.

Check that the correct current overloads are fitted and that the current being drawn does not exceed the motor nameplate value. Excessive current normally indicates that the ductwork system resistance is different to design.

7.4 Access to fan unit

Access to fan sections on non-control and control side of the unit as well as access to dampers and actuators is shown in Figure 1.

IMPORTANT

Isolation - Before commencing work, make sure that the unit, switched live and Nuair control are electrically isolated from the mains supply.

This page has been intentionally left blank

8.0 Description Of Control - Software Strategy

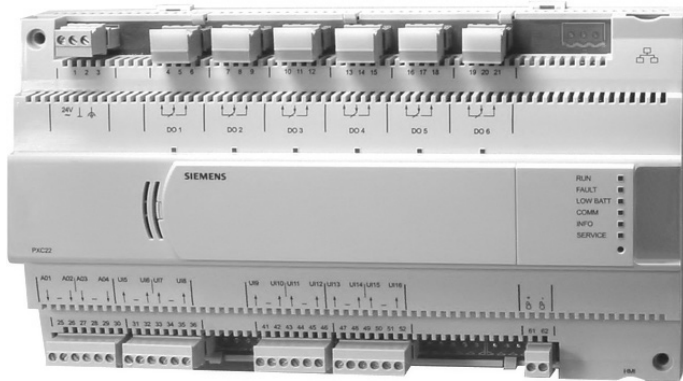

8.1 Unit Contains The Following Controllable Items:

- Inlet damper (if fitted).
- Extract damper (if fitted).
- Heat recovery & bypass damper.
- Heating coil.
- Supply fan speed.
- Extract fan speed.

8.2 Enable Signal

The unit can be enabled via the following methods:

- Software switch via strategy.
- Switched live (230VAC) input, PIR etc. via digital input.
- Low voltage contacts via digital input.
- Night cooling / summer free-cooling strategy.

When the enable signal is removed, the unit will run on for a time defined by the run-on setpoint. If an electric heater is fitted, the fans will automatically run-on for an extra 2 minutes, without heating, in order to dissipate residual heat.

8.3 Occupancy Control

When a Trend occupancy sensor is selected via UI4 & 5 software module, the control will look for a Trend OCC-U sensor in the appropriate input.

An occupied signal will give an enable signal.

0V = Occupied

14V = Unoccupied

8.4 Boost

When the control receives a boost signal the fans will run at boost speed. Once the signal is removed the fans will run on for a time defined by the boost run-on setpoint.

8.5 Trickle Mode

When trickle mode is active, the fans will run at their minimum speed even when there is no enable signal. Heating and cooling will also function in this mode if available.

8.6 CO₂ Control

When a CO₂ sensor is connected, CO₂ control is enabled via the CO₂ software switch and an enable signal is received, ventilation will increase to reduce CO₂ concentration the target CO₂ setpoint. The target CO₂ sensor setpoint can be changed as one of the commissioning setpoints.

8.7 Supply Temperature Control

While an enable signal is present, this mode modulates heating, cooling & heat exchanger bypass dampers with the aim of the supply air reaching the temperature setpoint. Please note that heating and cooling outputs will only function if the HeatingType or CoolingType setpoints are set to heating or cooling options.

8.8 Frost Protection

Should the internal temperature of the unit fall below a value defined in the commissioning variables, the control will override all heating/cooling logic to open the LPHW or CW control valves, if fitted. This is to allow any protective flow through the heating/cooling coils. The supply fan will also stop and the appropriate frost protection software module will enter an alarm state. This period will last for a minimum of 5 minutes by default. The fault relay will also open.

Please note that frost protection will only function if the HeatingType or CoolingType switches are set to LPHW or CW.

8.9 Night Cooling / Summer Free Cooling

Once enabled in software, this routine uses an individual time schedule to cool the fabric of the building at night using only the external air. This mode only functions if the daytime temperature is above the setpoint, cooling is possible and if the cooling air is not too cold.

8.10 Alarms

8.10.1 CRITICAL ALARM (LATCHING)

Once in critical alarm state the unit will drive all heating and cooling outputs to 0V. Other functions continue as normal. The critical alarm is latched and required manual reset to clear.

Causes of critical alarm:

- Fan fail via alarm circuit 1.
- Heater overtemp via alarm circuit 1.

8.10.3 Maintenance Alarms (Non-Latching)

Once in maintenance alarm state the only action taken is de-energising of the fault relay. Once the trigger is removed, the alarm will reset automatically.

Causes of maintenance alarm:

- Sensor failure
- Low supply temperature, default 8°C.
- Frost protection routine active, default 4°C (Only runs if water valves are selected as fitted).
- Excessively high supply temperature reading (Will stop heating).
- Filter fault

All alarms have a hold off period set by the setpoint "Alarm delay".

8.10.2 Thermal Trip

In case of software failure, as a final resort, the electric heater is protected by a fail-safe thermal overload switch. This switch disables the heater controller via a contactor once the temperature reaches 80°C. When this occurs, the critical alarm will latch in software.

Once the unit cools, the contactor will re-engage but the heater signal will remain at 0V until the critical fault is reset in software or by power cycle.

XBOXER XBC 10-65 Ecosmart Adapt (Siemens) Control (AS)

9.0 Description Of Control - Touch Screen Ancillary

Below is an optional control solution ancillary for your application. For the full range and technical details, please contact Nuaire.

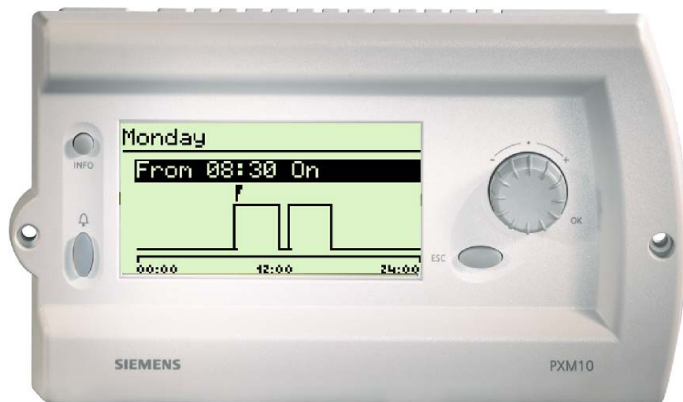

PXM10 Touch Screen Display (9 x 5 inch).

Local operator unit for monitoring and operation of ONE PX compact or PX modular automation station.

- High-grade display with adjustable contrast.
- Easy operation with a push-dial, giving direct access to the required plant information.
- Choice of generic view or "Favourites" view for operation and display of plant functions (alarm handling, time schedules, calendars, set point adjustments, display of measured values, etc.).
- System date and time setting
- Optimized for use in a fixed location

The PXM10 unit is suitable for mounting in control panel fronts or vertical panels (e.g. remote operating panels or similar units). The unit is also suitable for DIN rail snap mounting.

10.0 Electrical Details

The electrical wiring must be carried out by competent persons, in accordance with good industry practice and should conform to all governing and statutory bodies i.e. IEE, CIBSE etc.

10.1 Supply

The control is powered by a 240Vac 50Hz supply. This must be isolated local to the unit and fitted with appropriate overcurrent and fault protection.

10.1.1 Electric Heater Supply

For models with electric heating, the heating circuit is powered by a separate, higher current, 240VAC supply.

This must be isolated local to the unit and fitted with appropriate overcurrent protection. The main supply is still required.

Electric Heater models require two separate supplies, each with an appropriate overcurrent current protection device.

10.1.2 Electrical Supply Details - FLC

Unit Code	Main Circuit (FLC)	Electric Heater Circuit (Electric Heater Models Only*)
XBC10-H-*AS	1.5 A	6 A
XBC15-H-*AS	2.8 A	13 A
XBC25-H-*AS	6.4 A	19 A
XBC45-H-*AS	6.9 A	19A
XBC55-H-*AS	6.9 A	38 A
XBC65-H-*AS	8 A	38 A

*Electric Heater models require two separate supplies, each with an appropriate overcurrent current protection device.

10.2 Volt Free Contacts

Note that the volt free contacts are not fused. If these are used to power any external equipment, the installer must provide adequate fusing or other protections.

These contacts are rated at 2A resistive.

Run connections - The relay is powered when the fan is running.

Fault connections - No fault = the relay is powered.

Fault = the relay is unpowered.

Heat demand - the relay is powered when heating is selected.

Cool demand - the relay is powered when cooling is selected.

10.3 Switched Live

Switch Live (SL) terminal - A signal of 100-230V AC will activate the switched live signal.

Switch Live 2 Boost (SL2) terminal - A signal of 100-230V AC will activate the switched live 2 (Fan Boost) signal.

Volt free versions of the switched live signals are also available at terminals T33-T34 & T35-T36. Link two contacts to activate the signal.

10.4 Damper Connections

A fan start delay can be imposed to allow the damper time to open. This is adjustable via the strategy.

10.5 Network Settings

Default IP address: 192.168.11.12
Subnet mask: 255.255.255.0

A copy of the strategy is stored in the EDoS (Engineering Data on Site) portion of memory.

XBOXER XBC 10-65 Ecosmart Adapt (Siemens) Control (AS)

10.6 Connection Chart

Description	TD	Short Name	Subsystem	Signal Address	Block Type	Signal Type	Unit	Min	Max
Fresh Air Temp	AHU'2Sensors'1FreshAir	1FreshAir	C	1.1	AI	R1K	°C	0	50
Supply Air Temp	AHU'2Sensors'2SupAlr	2SupAlr	C	1.2	AI	R1K	°C	-50	80
Extract Air Temp	AHU'2Sensors'3ExtAir	3ExtAir	C	1.3	AI	R1K	°C	-50	80
CO2 Sensor	AHU'2Sensors'4CO2	4CO2	C	1.4	AI	U10	Parts Per Million	0	2000
Fan Speed Cntrl	AHU'2Sensors'5FnSdCnt	5FnSdCnt	C	1.5	AI	U10	%	0	10
Alm Critical	AHU'3DigIns'AlmCritC1	AlmCritC1	C	1.6	BI	D20	Nml/Alm		
Alm Maintenance	AHU'3DigIns'AlmFitC2	AlmFtC2	C	1.7	BI	D20	Nml/Alm		
Enable Hware	AHU'3DigIns'EnaHW	EnaHW	C	1.8	BI	D20	No, Yes		
Boost Ena Hware	AHU'3DigIns'BoostHW	BoostHW	C	1.9	BI	D20	No, Yes		
OCC PIR Hware	AHU'3DigIns'OccPIR	OccPIR	C	1.10	BI	D20	UnOcc/Occ		
SupFan AirFlo	AHU'3DigIns'SpFnDPS	SpFnDPS	C	1.11	BI	D20	NoFlo/Flow		
ExtFan AirFlo	AHU'3DigIns'ExtFnDPS	ExtFnDPS	C	1.12	BI	D20	NoFlow/Flow		
Extract Speed	AHU'6Outpts'4ExtFan	4ExtFan	C	4.1	AO	Y10S	%	0	100
Supply Speed	AHU'6Outpts'3SupFan	3SupFan	C	4.2	AO	Y10S	%	0	100
Heating Sig	AHU'6Outpts'7HtgSig	7HtgSig	C	4.3	AO	Y10S	%	0	100
Cooling Sig	AHU'6Outpts'91ClgSig	91ClgSig	C	4.1	AO	Y10S	%	0	100
Bypass Dmp	AHU'6Outpts'5DmpCnt	5DmpCnt	C	5.1	BO	Q250	Reclaim/Bypass		
Fault Relay	AHU'6Outpts'92FltRly	92FltRly	C	5.2	BO	Q250	Off, On		
Fan Enabled Rly	AHU'6Outpts'2FanEna	2FanEna	C	5.3	BO	Q250	Off, On		
Chilled Dmd Relay	AHU'6Outpts'8ClgDmd	8ClgDmd	C	5.4	BO	Q250	No, Yes		
Heat Dmd Relay	AHU'6Outpts'6HtgDmd	6HtgDmd	C	5.5	BO	Q250	No, Yes		
IO Damper	AHU'6Outpts'11IODmp	11IODmp	C	5.6	BO	Q250	Close, Open		

XBOXER XBC 10-65 Ecosmart Adapt (Siemens) Control (AS)

10.7 Terminals - Wire Connections

Figure 22. This control unit utilises WAGO's CAGE CLAMP® S terminal blocks, allowing for quick and easy connection.

PUSH IN TERMINATION - Stripped solid conductors, fine-stranded conductors with ferrules, or ultrasonically "bonded" conductors are simply pushed in until they hit the backstop. No tool required.

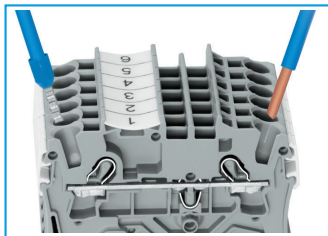

TERMINATION OF FINE-STRANDED CONDUCTORS - Open the clamp by inserting an operating tool (as shown below) until it clicks into position. Then insert the conductor and remove the operating tool to complete the connection.

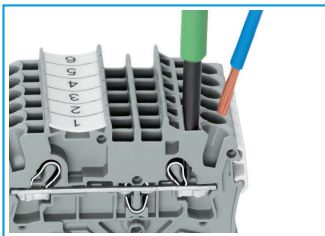

CONDUCTOR REMOVAL - Insert an operating tool in to the operating slot to remove the conductor, just like the original CAGE CLAMP® terminals blocks.

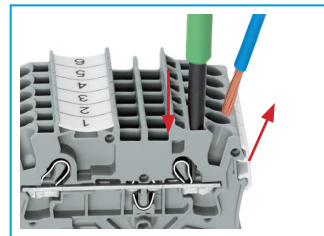

JUMPERS - Terminal blocks can be connected together to increase the number of terminals at the same potential using push-in jumpers. In these cases the terminals are treated as one conductor.

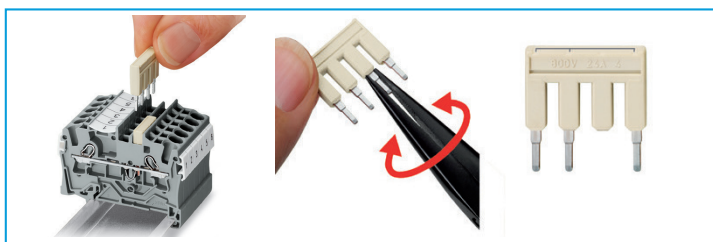

JUMPER REMOVED - Insert the operating tool blade between the jumper and the partition wall of the dual jumper slots, then lift up the jumper.

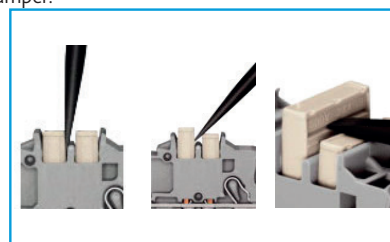

DOUBLE DECK TERMINAL BLOCK - Each deck has a different potential (2-conductor), which creates a space saving on the rail. Decks can be connected to adjacent terminal blocks and/or the top to the bottom deck.

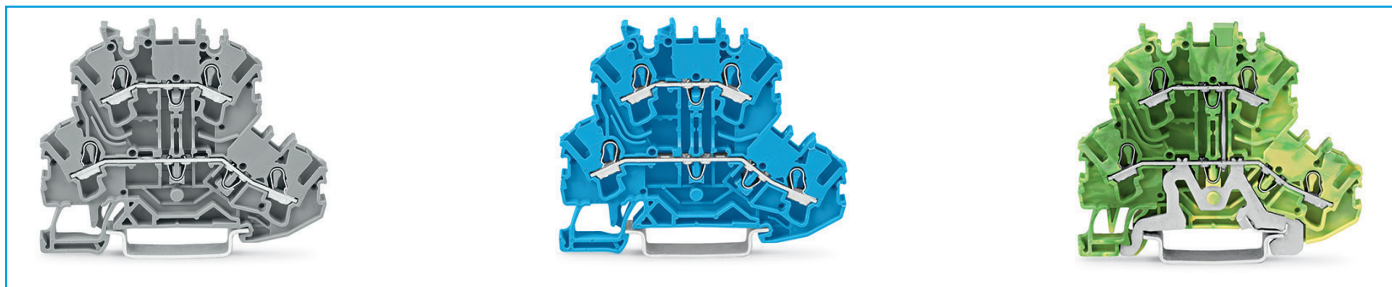

EARTH TERMINAL BLOCKS

The earth terminal block (green/yellow) has a direct electrical connection to the DIN rail, with the earthing foot (earth connection only).



FUSE TERMINALS

Replaceable cartridge fuses are housed in quick release fuse terminals.

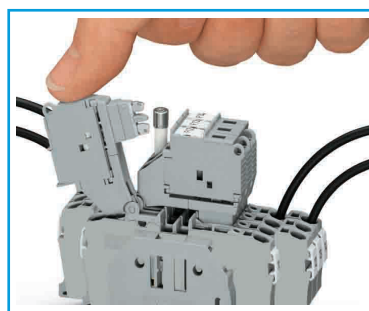

XBOXER XBC 10-65 Ecosmart Adapt (Siemens) Control (AS)

11.0 Connection and Wiring Diagrams

11.1 Hardware Positions On The Unit

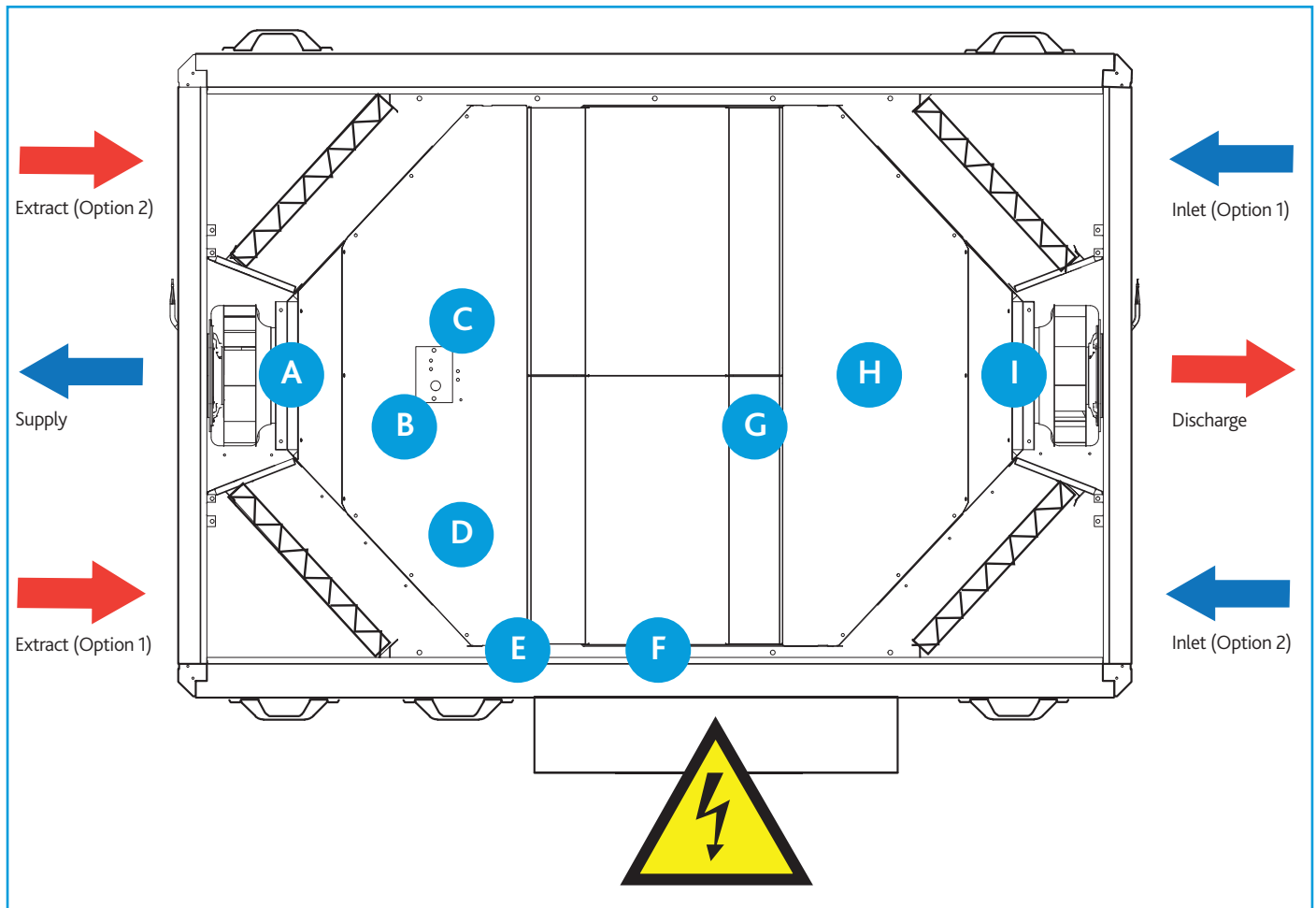

KEY TO HARDWARE POSITIONS

- A) Supply fan (drive & health)
- B) Delivery air temperature sensor
- C) Extract air temperature sensor
- D) Re-heater trip (electric heater models only)
- E) LPHW re-heat drive (LPHW models only)
- F) Bypass damper drive
- G) Condensate pump alarm
- H) Fresh air temperature
- I) Extract fan (drive & health)

XBOXER XBC 10-65 Ecosmart Adapt (Siemens) Control (AS)

11.2 Physical Layout

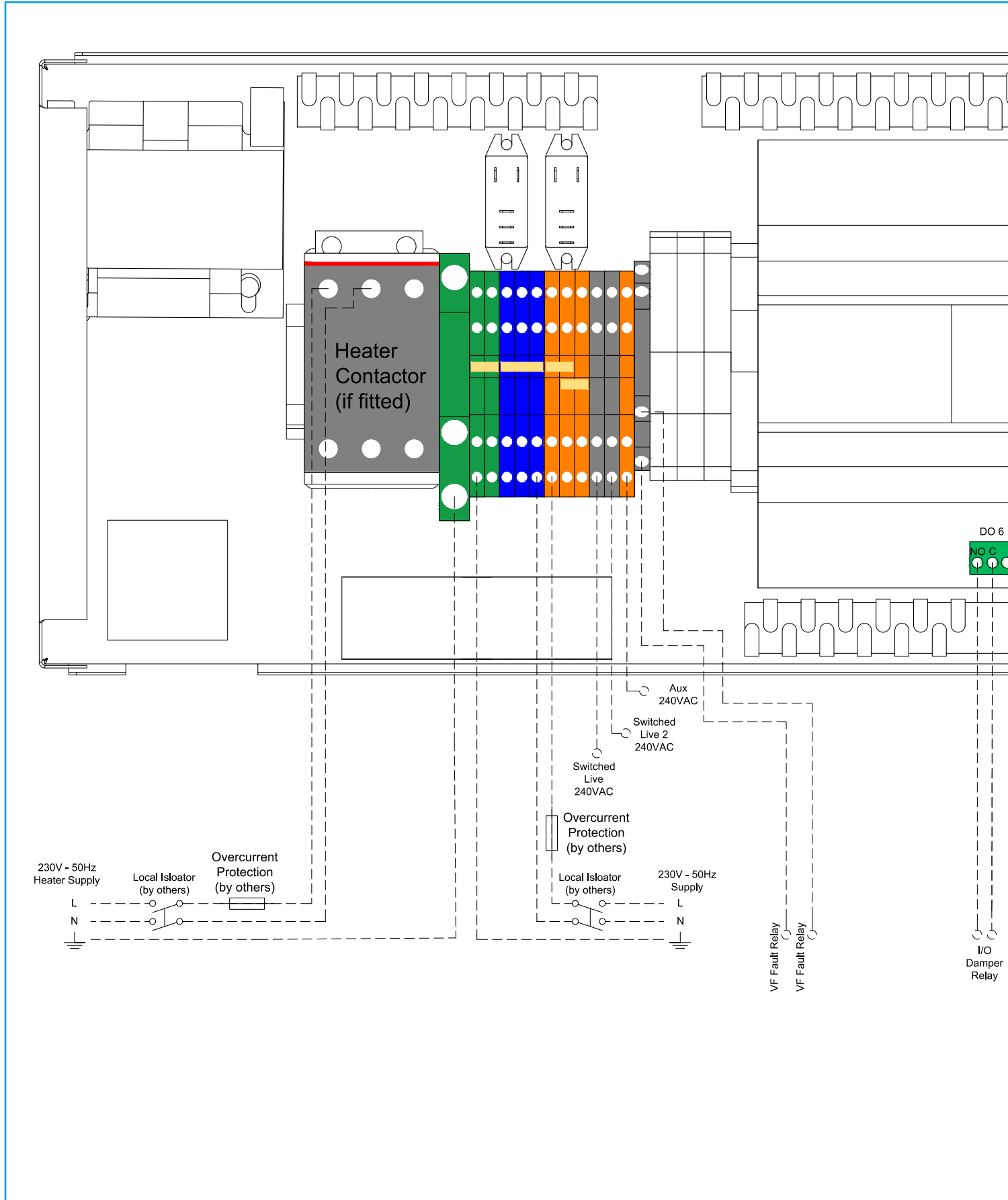

XBOXER XBC 10-65 Ecosmart Adapt (Siemens) Control (AS)

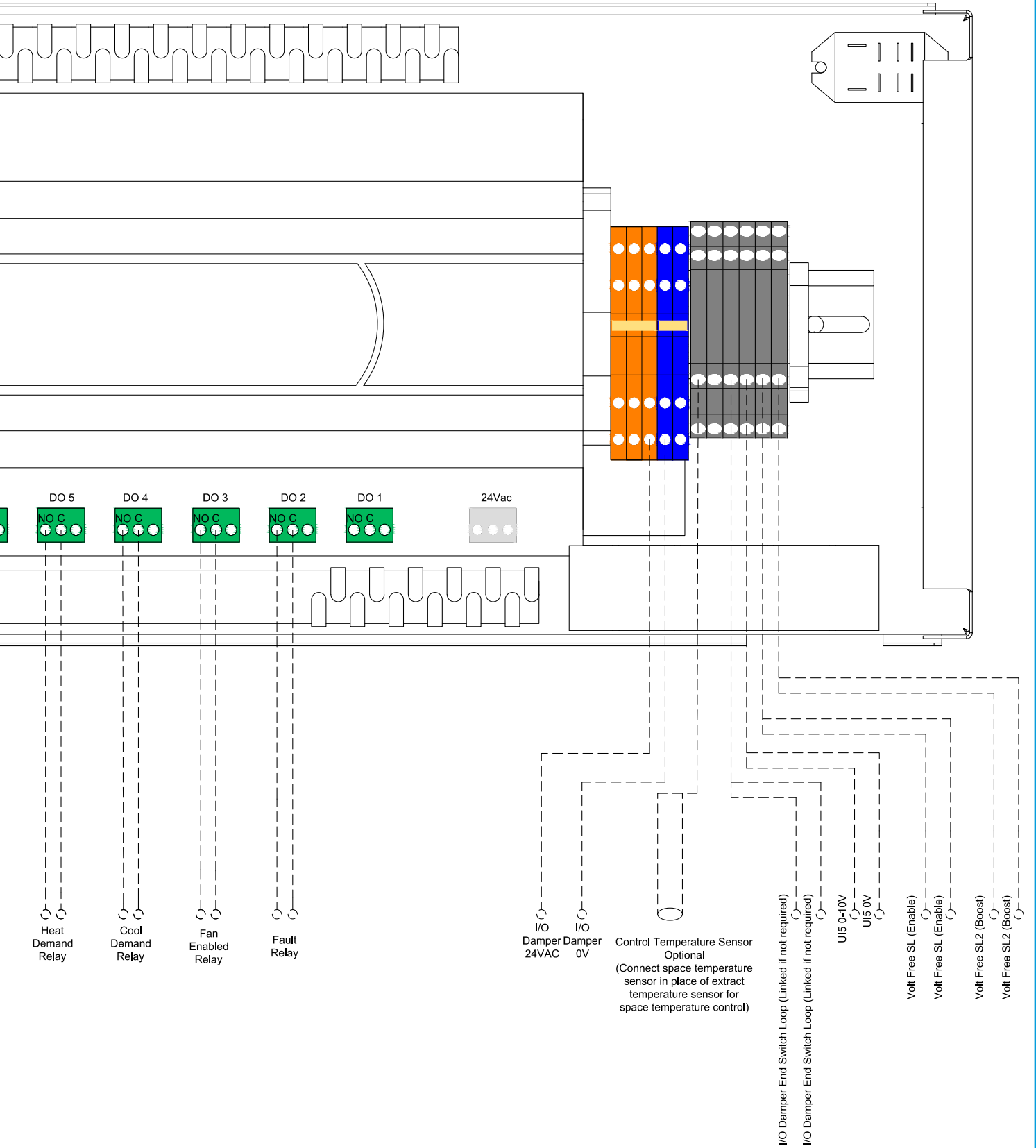

XBOXER XBC 10-65 Ecosmart Adapt (Siemens) Control (AS)

11.3 XBC10-15 (No Heater/LPHW)

Siemens Control XBC10-15

Key:

Internal Factory Connection 
Optional External Connection 

A1 : 24VAC Bypass Damper Actuator
A4 : Tacho Alarm Converter
A5 : Inlet/Outlet Dampers (Optional)

F1 : Auxiliary Fuse 1A
F2 : Supply Fan Fuse 8A
F3 : Extract Fan Fuse 8A
F4 : Condensate Pump Fuse 1A
F6 : ELV Fuse 2.5A

R1 : 240VAC Switched Live Input SPDT
R2 : 240VAC Switched Live 2 (Boost) Input SPDT
R3 : 24VAC Condensate Pump Alarm DPDT

S1 : Fresh Air Temp. Ni1000
S2 : Supply Air Temp. Ni1000
S3 : Extract Air Temp Ni1000
S4 : Space Air Temp Ni1000

TR : Isolating Transformer 240VAC - 24VAC
W1 : Condensate Pump Alarm Contacts

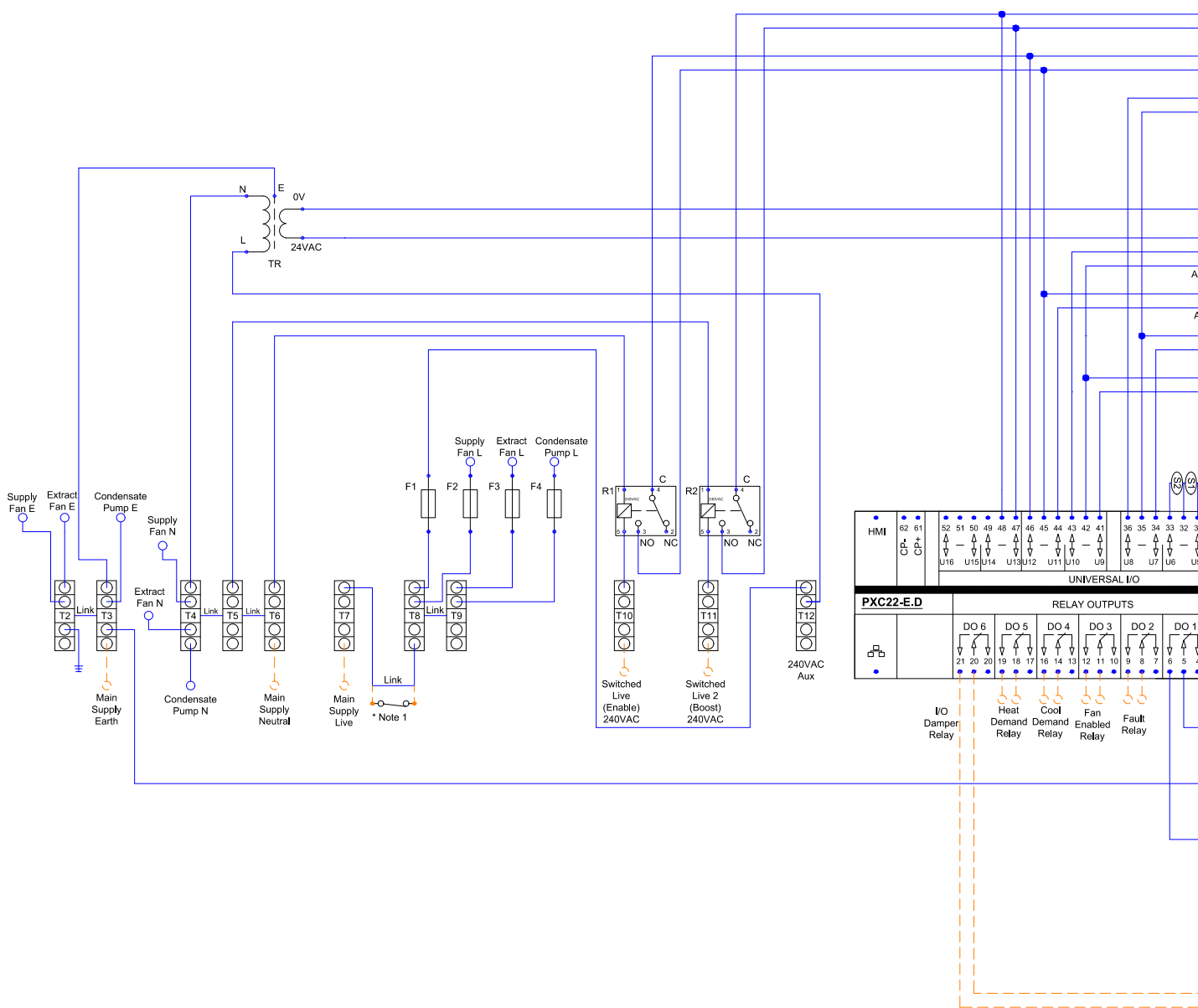

* Note1 Emergency shutdown circuit. Break to remove power, Remove link T7-T8 to use.
* Note2 Connect external S4 sensor in place of S3 sensor for space temperature control.
* Note3 Shutoff damper end-switch loop. Remove link T29-T30 to include within alarm circuit 2

XBOXER XBC 10-65 Ecosmart Adapt (Siemens) Control (AS)

Control (No Heater / LPHW)

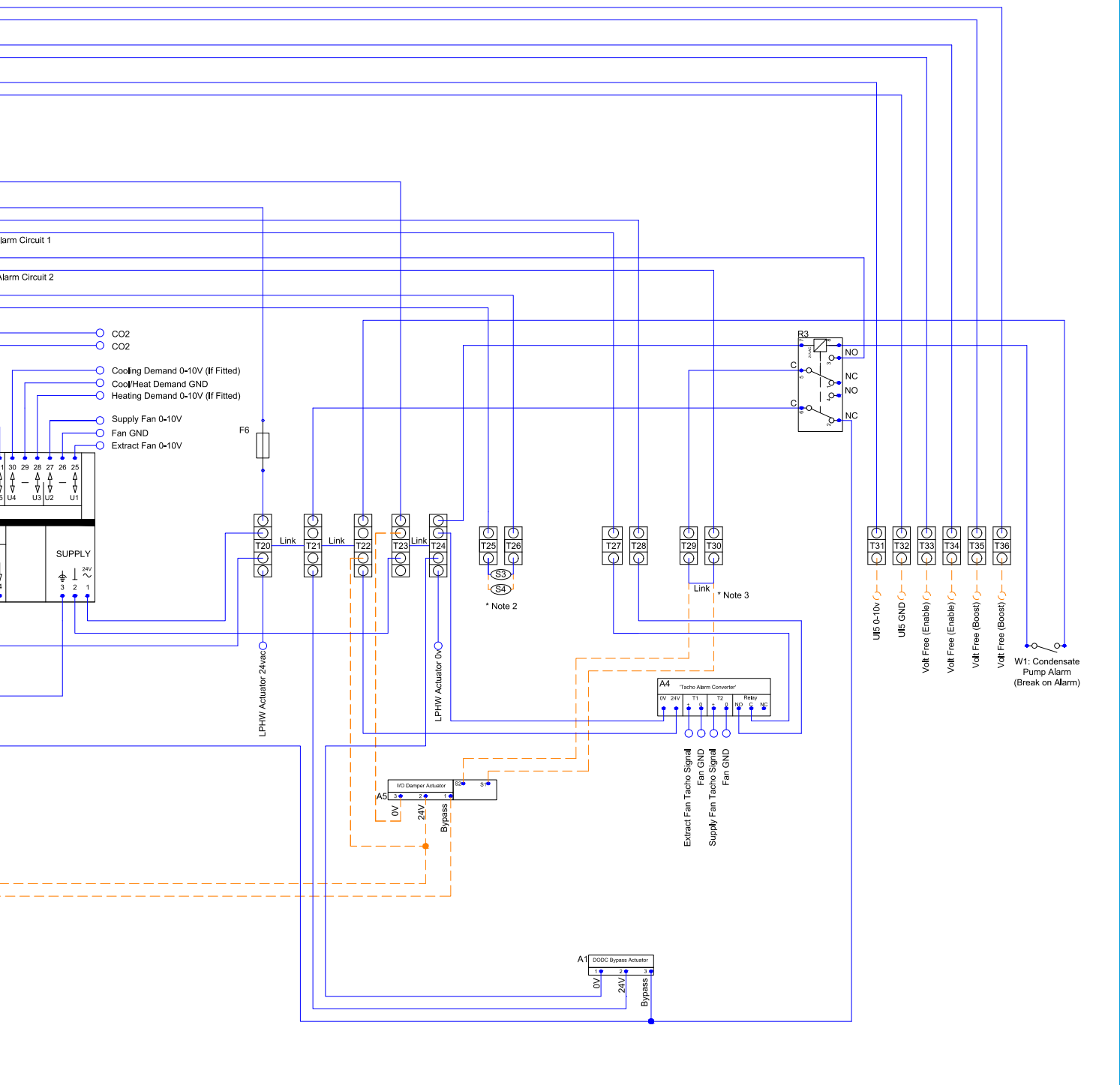



XBOXER XBC 10-65 Ecosmart Adapt (Siemens) Control (AS)

11.4 XBC25-65 (No Heater/LPHW)

Siemens Control XBC25-65

Key:

Internal Factory Connection 
Optional External Connection 

A1 : 24VAC Bypass Damper Actuator
A2 : 24VAC Bypass Damper Actuator
A5 : Inlet/Outlet Dampers (Optional)

F1 : Auxiliary Fuse 1A
F2 : Supply Fan Fuse 8A
F3 : Extract Fan Fuse 8A
F4 : Condensate Pump Fuse 1A
F6 : ELV Fuse 2.5A

R1 : 240VAC Switched Live Input SPDT
R2 : 240VAC Switched Live 2 (Boost) Input SPDT
R3 : 24VAC Condensate Pump Alarm DPDT

S1 : Fresh Air Temp. Ni1000
S2 : Supply Air Temp. Ni1000
S3 : Extract Air Temp Ni1000
S4 : Space Air Temp Ni1000

TR : Isolating Transformer 240VAC - 24VAC

W1 : Condensate Pump Alarm Contacts
W2 : Supply Fan Motor Alarm Contacts
W3 : Extract Fan Motor Alarm Contacts

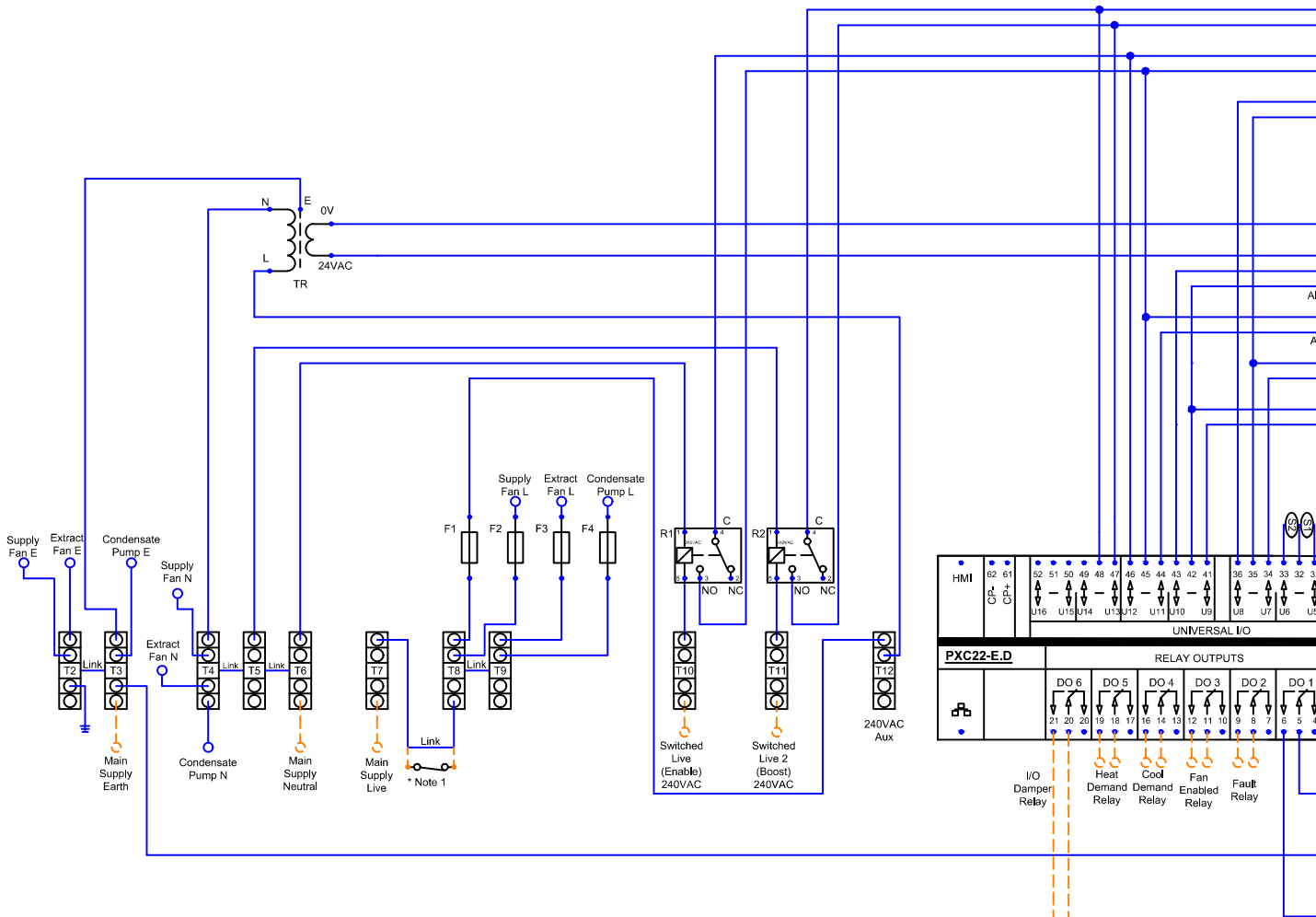

* Note1 Emergency shutdown circuit. Break to remove power. Remove link T7-T8 to use.
* Note2 Connect external S4 sensor in place of S3 sensor for space temperature control.
* Note3 Shutoff damper end-switch loop. Remove link T29-T30 to include within alarm circuit 2

XBOXER XBC 10-65 Ecosmart Adapt (Siemens) Control (AS)

Control (No Heater / LPHW)

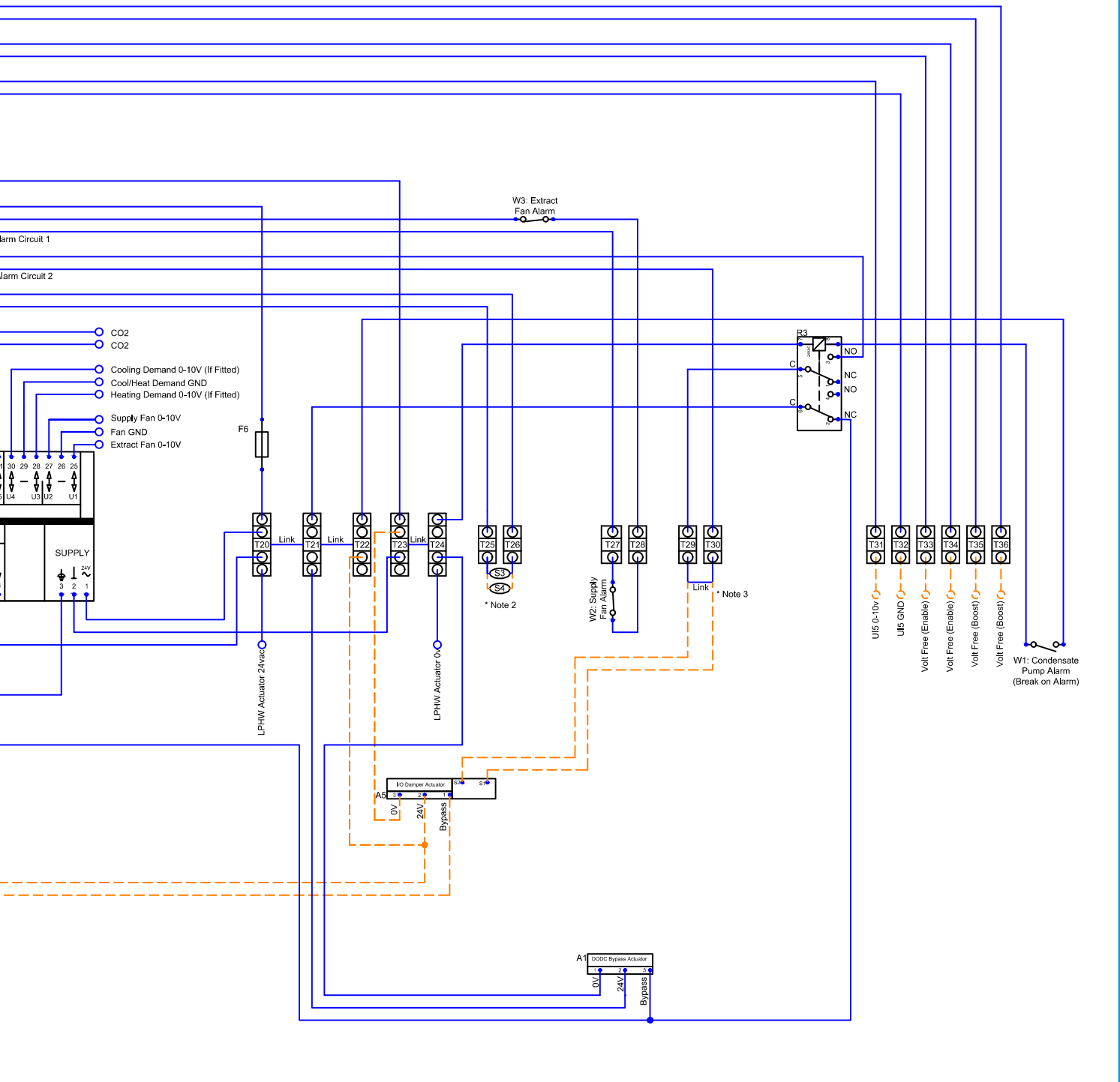

XBOXER XBC 10-65 Ecosmart Adapt (Siemens) Control (AS)

11.5 XBC10-15 (Electric Heater)

Siemens Control XBC10-15

Key:

Internal Factory Connection 
Optional External Connection 

A1 : 24VAC Bypass Damper Actuator
A3 : Electric Heater Controller
A4 : Tacho Alarm Converter
A5 : Inlet/Outlet Dampers (Optional)

F1 : Auxiliary Fuse 1A
F2 : Supply Fan Fuse 8A
F3 : Extract Fan Fuse 8A
F4 : Condensate Pump Fuse 1A
F6 : ELV Fuse 2,5A

R1 : 240VAC Switched Live Input SPDT
R2 : 240VAC Switched Live 2 (Boost) Input SPDT
R3 : 24VAC Condensate Pump Alarm DPDT
R5 : 240VAC Heater On-Delay Relay (3 Seconds)

C1 : Electric Heater Trip Contactor 240VAC 11kW

S1 : Fresh Air Temp. Ni1000
S2 : Supply Air Temp. Ni1000
S3 : Extract Air Temp Ni1000
S4 : Space Air Temp Ni1000

TR : Isolating Transformer 240VAC - 24VAC

W1 : Condensate Pump Alarm Contacts
W4 : Heater Thermal Trip

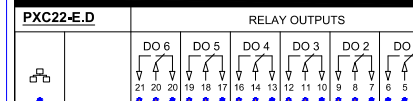
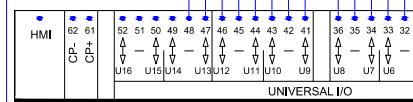
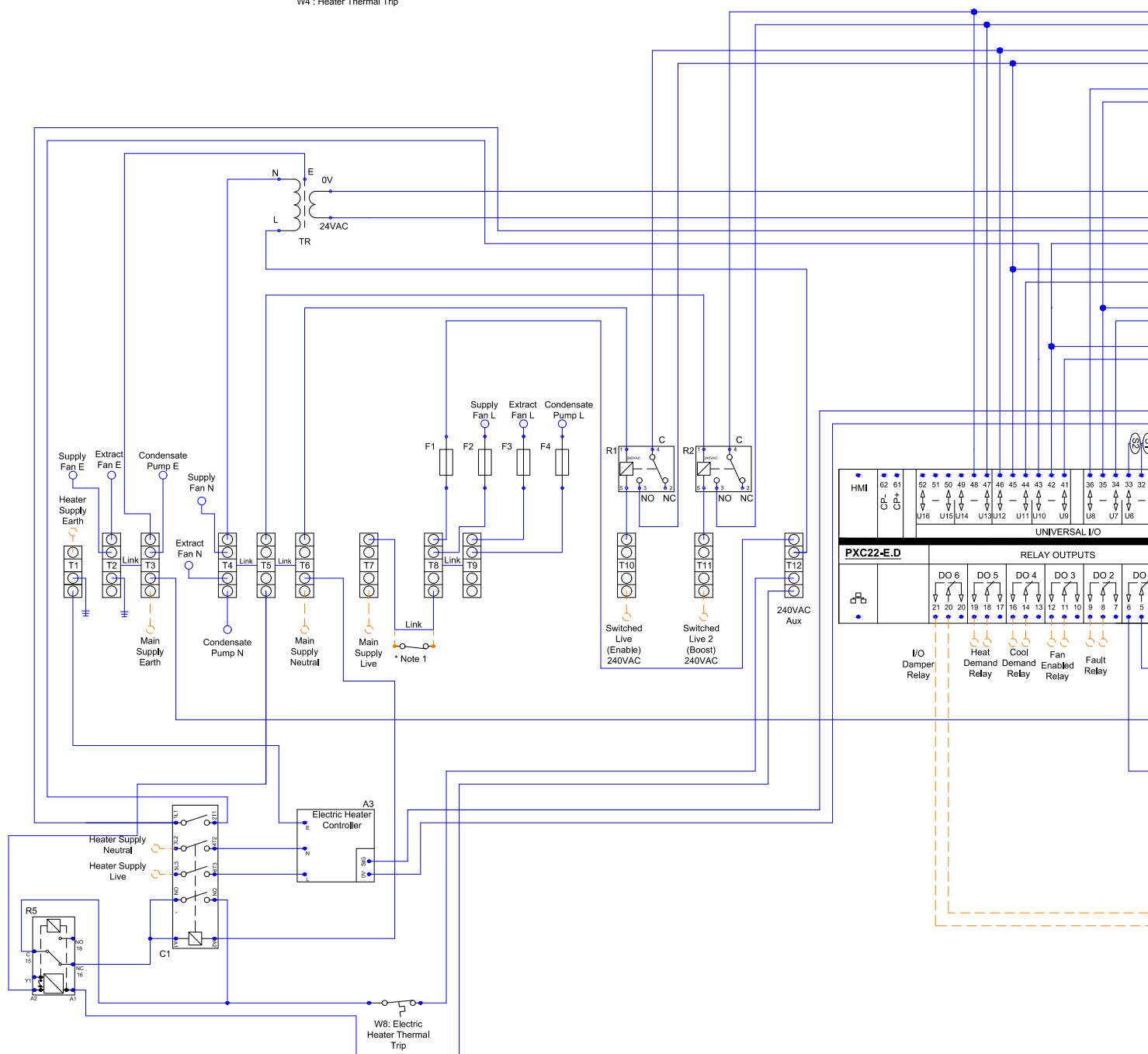

- * Note1 Emergency shutdown circuit. Break to remove power. Remove link T7-T8 to use.
- * Note2 Connect external S4 sensor in place of S3 sensor for space temperature control.
- * Note3 Shutoff damper end-switch loop. Remove link T29-T30 to include within alarm circuit 2

XBOXER XBC 10-65 Ecosmart Adapt (Siemens) Control (AS)

Control (Electric Heater)

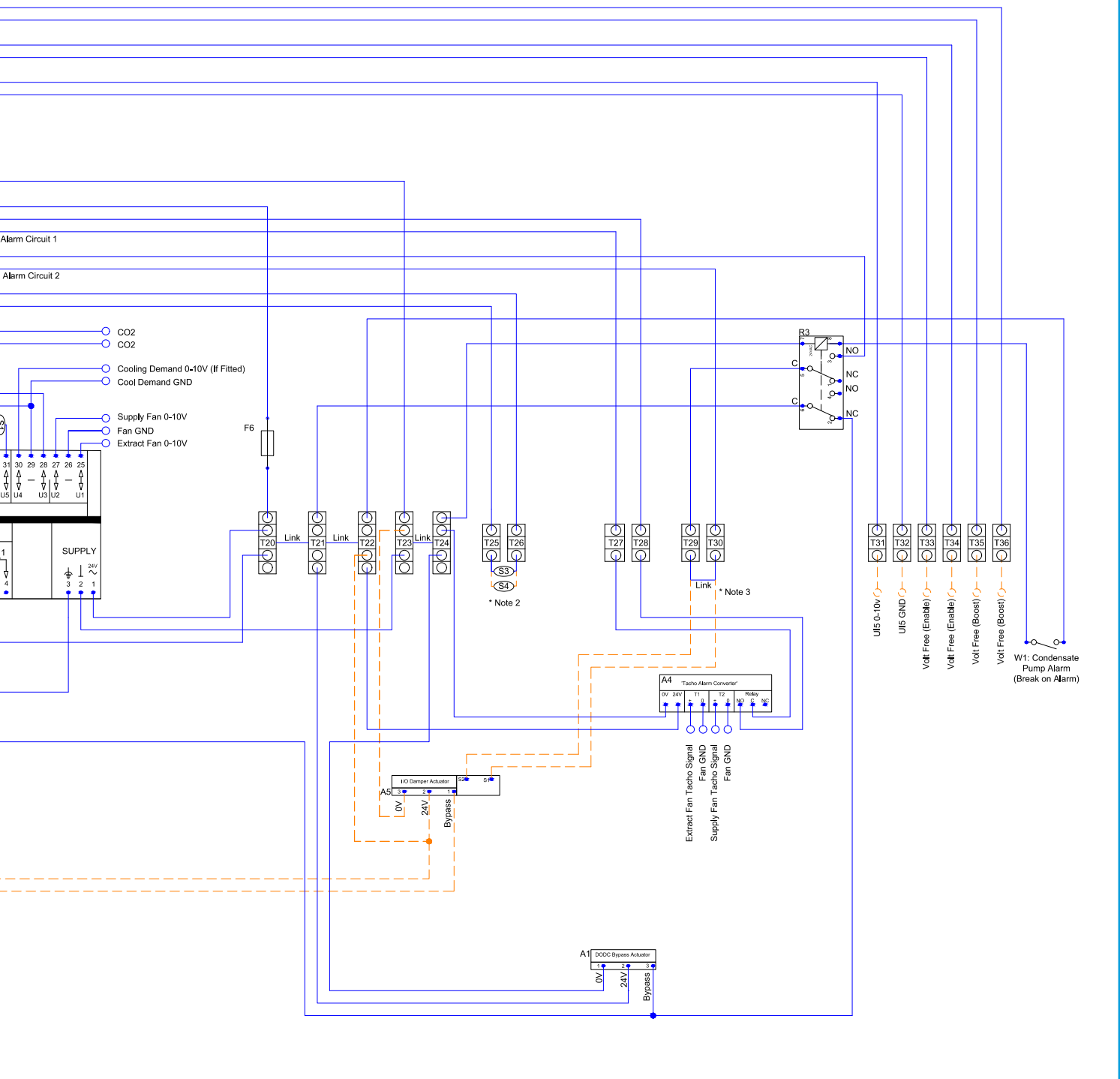



XBOXER XBC 10-65 Ecosmart Adapt (Siemens) Control (AS)

11.6 XBC25-65 (Electric Heater)

Siemens Control XBC25-65

Key:

Internal Factory Connection 
Optional External Connection 

A1 : 24VAC Bypass Damper Actuator
A3 : Electric Heater Controller
A5 : Inlet/Outlet Dampers (Optional)

F1 : Auxiliary Fuse 1A
F2 : Supply Fan Fuse 8A
F3 : Extract Fan Fuse 8A
F4 : Condensate Pump Fuse 1A
F6 : ELV Fuse 2.5A

R1 : 240VAC Switched Live Input SPDT
R2 : 240VAC Switched Live 2 (Boost) Input SPDT
R3 : 24VAC Condensate Pump Alarm DPDT
R5 : 240VAC Heater On-Delay Relay (3 Seconds)

C1 : Electric Heater Trip Contactor 240VAC 11kW

S1 : Fresh Air Temp. Ni1000
S2 : Supply Air Temp. Ni1000
S3 : Extract Air Temp Ni1000
S4 : Space Air Temp Ni1000

TR : Isolating Transformer 240VAC - 24VAC

W1 : Condensate Pump Alarm Contacts
W2 : Supply Fan Motor Alarm Contacts
W3 : Extract Fan Motor Alarm Contacts
W4 : Heater Thermal Trip

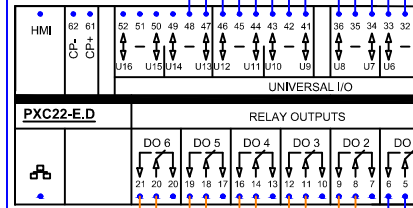
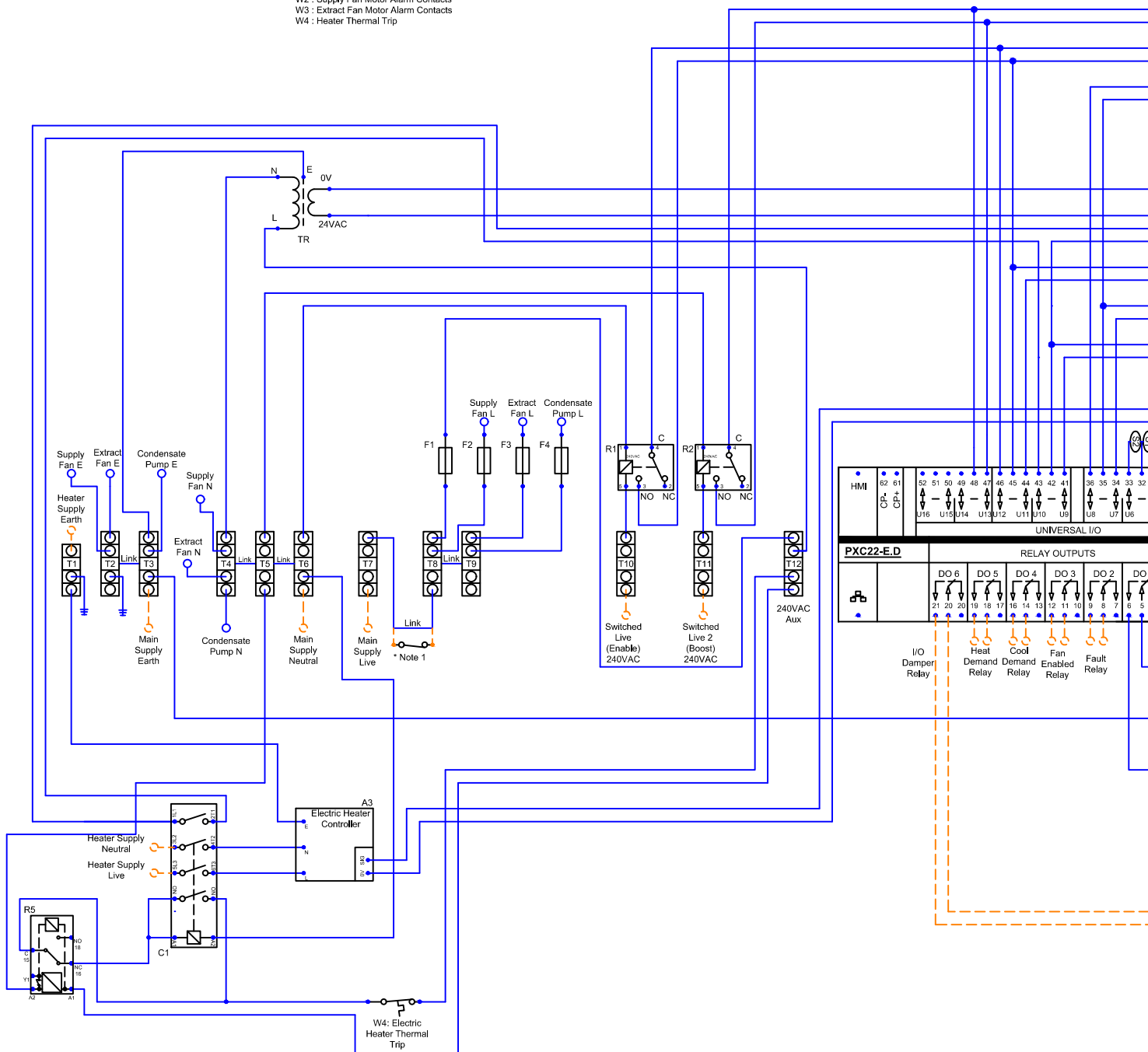

- * Note1 Emergency shutdown circuit. Break to remove power. Remove link T7-T8 to use.
- * Note2 Connect external S4 sensor in place of S3 sensor for space temperature control.
- * Note3 Shutoff damper end-switch loop. Remove link T29-T30 to include within alarm circuit 2

XBOXER XBC 10-65 Ecosmart Adapt (Siemens) Control (AS)

Control (Electric Heater)

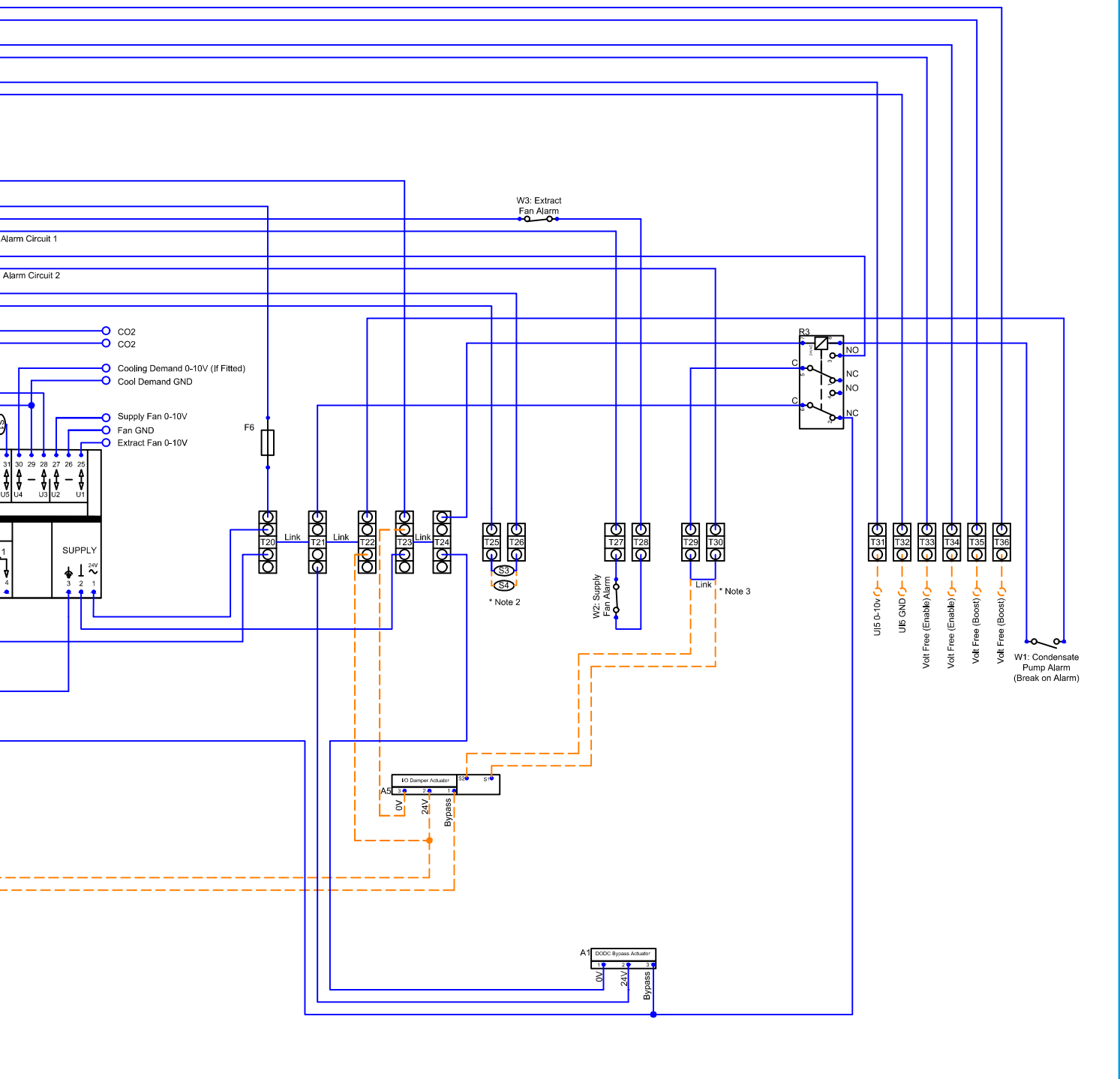

XBOXER XBC 10-65 Ecosmart Adapt (Siemens) Control (AS)

12.0 Maintenance

It is recommended that PPE is always used during the maintenance of Air Handling Equipment – gloves, eye shields and respiratory mask.

IMPORTANT

Isolation - Before commencing work, make sure that the unit and Nuair control are electrically isolated from the mains supply.

In some Ecosmart units and in some third party controls, variable speed drives (inverters) are used to provide fan speed control. After the fan is isolated, allow at least 5 minutes for the capacitors in the inverter to discharge before commencing any work on the unit.

12.1 Dampers

Regularly check that the damper blades move freely.

12.2 Filters (4 x G4 Fitted as standard)

Disposable filters should be changed when an appropriate pressure drop is achieved.

12.3 Heating Coils

Coils should have their finned surface examined for accumulation of dirt, lint and biological contaminants or similar.

If necessary, wash down affected areas with a mild detergent solution and a soft brush. Care should be taken not to damage the finned surface and any cleaning fluids should be rinsed away with water. A compressed air line may be used to blow out any solids between fins. Do not probe the coil fin block with metal objects as damage may cause leaks.

Drain lines should be checked to ensure that they are unobstructed and free draining.

Drain pans should be flushed out periodically to remove contamination.

Note: The unit application may require particular attention to this item – Check with Building Management personnel for details.

12.4 Counterflow Plate Heat Exchanger

The heat exchanger block is normally protected from dust and contamination by upstream pre-filters. It is possible to clean the unit with compressed air in the case of dust deposits or by spraying with a mild detergent solution for grease deposits. Solvents, strong alkaline, acidic or any products that may be aggressive to aluminium should not be used. Do not use cleaning water over a temperature of 50 °C.

Drain lines should be checked to ensure that they are unobstructed and free draining. Traps should be checked that they are fully primed and functioning.

Drain pans should be flushed out periodically to remove contamination, and chemical treatments may be used to provide protection between service visits.

Note: The unit application may require particular attention to this item – Check with Building Management personnel for details.

12.5 Fans and Motors

Fan bearings should be manually checked at regular intervals for condition. Standard fan bearings are supplied as 'sealed for life' and have an anticipated life of 40,000 hours.

Motors have an enclosed bearing housing and are pre-greased for life. Check all fixings are secure.

12.6 General

Inspect all internal and external surfaces to check for corrosion or peeling of painted surfaces.

Thoroughly clean affected areas with a wire brush, apply a coat of zinc rich primer or similar, and re-touch with suitable finishing paint. Ensure tightness of all nuts, bolts, and fixings.

Check all components for general condition.

13.0 Service Schedule

Typical—will depend on site conditions

	6 MONTHS	12 MONTHS
G4 FILTERS	✓ or	✓
F7 FILTERS	✓	
DAMPERS		✓
DAMPER ACTUATORS		✓
VENT WATER COILS		✓
COIL FINNED SURFACES		✓
CHECK DRAIN LINES + DRIP TRAY	✓	✓
CHECK DRAIN PANS	Building Schedule?	✓
NUTS, BOLTS, FIXINGS SECURE		✓
FAN BEARINGS	✓	
ELECTRIC HEATERS		✓
ELECTRICAL WIRING		✓
FAN IMPELLER	✓	
GENERAL		✓

14.0 Warranty

5 year warranty on Ecosmart models for peace of mind. Basic control models have a 2 year warranty. The warranty starts from the day of delivery and includes parts and labour for the first year. The remaining period covers replacement parts only.

This warranty is void if the equipment is modified without authorisation, is incorrectly applied, disassembled misused or not installed commissioned and maintained in accordance with the details contained in this manual and general good practice.

The product warranty applies to the UK mainland and in accordance with Clause 14 of our Conditions of Sale. Customers purchasing from outside of the UK should contact Nuair International Sales office for further details.

15.0 After Sales Enquiries

For technical assistance or further product information, including spare parts and replacement components, please contact the After Sales Department.

Telephone 02920 858 400
aftersales@nuaire.co.uk

DECLARATION OF INCORPORATION AND INFORMATION FOR SAFE INSTALLATION, OPERATION AND MAINTENANCE

We declare that the machinery named below is intended to be assembled with other components to constitute a system of machinery. All parts except for moving parts requiring the correct installation of safety guards comply with the essential requirements of the Machinery Directive. The machinery shall not be put into service until the system has been declared to be in conformity with the provisions of the EC Machinery Directive.

Signature of manufacture representatives:

Name:		Position:	Date:
1) C. Biggs		Technical Director	13. 05. 16.
2) A. Jones		Manufacturing Director	13. 05. 16.

Designation of machinery: XBOXER XBC Ecosmart Adapt Siemens (AS) Models

Machinery Types: Supply & Extract fans with Heat Recovery

Relevant EC Council Directives: 2006/42/EC (Machinery Directive)

Applied Harmonised Standards: BS EN ISO 12100, BS EN ISO 13857 EN60204-1, BS EN ISO 9001

Applied National Standards: BS848 Parts 1, 2.2 and 5

Note: All standards used were current and valid at the date of signature.

INFORMATION FOR SAFE INSTALLATION, OPERATION AND MAINTENANCE OF NUAIRE VENTILATION EQUIPMENT

To comply with EC Council Directives 2006/42/EC Machinery Directive and 2014/30/EU (EMC).
To be read in conjunction with the relevant product documentation (see 2.1)

1.0 GENERAL

1.1 The equipment referred to in this Declaration of Incorporation is supplied by Nuairé to be assembled into a ventilation system which may or may not include additional components. The entire system must be considered for safety purposes and it is the responsibility of the installer to ensure that all of the equipment is installed in compliance with the manufacturers recommendations and with due regard to current legislation and codes of practice.

2.0 INFORMATION SUPPLIED WITH THE EQUIPMENT

2.1 Each item of equipment is supplied with a set of documentation which provides the information required for the safe installation and maintenance of the equipment. This may be in the form of a Data sheet and/or Installation and Maintenance instruction. Each unit has a rating plate attached to its outer casing. The rating plate provides essential data relating to the equipment such as serial number, unit code and electrical data. Any further data that may be required will be found in the documentation. If any item is unclear or more information is required, contact Nuairé.

2.3 Where warning labels or notices are attached to the unit the instructions given must be adhered to.

3.0 TRANSPORTATION, HANDLING AND STORAGE

3.1 Care must be taken at all times to prevent damage to the equipment. Note that shock to the unit may result in the balance of the impeller being affected.

3.2 When handling the equipment, care should be taken with corners and edges and that the weight distribution within the unit is considered. Lifting gear such as slings or ropes must be arranged so as not to bear on the casing.

3.3 Equipment stored on site prior to installation should be protected from the weather and steps taken to prevent ingress of contaminants.

4.0 OPERATIONAL LIMITS

4.1 It is important that the specified operational limits for the equipment are adhered to e.g. operational air temperature, air borne contaminants and unit orientation.

4.2 Where installation accessories are supplied with the specified equipment e.g. wall mounting brackets. They are to be used to support the equipment only. Other system components must have separate provision for support.

4.3 Flanges and connection spigots are provided for the purpose of joining to duct work systems. They must not be used to support the ductwork.

4.4 **Local Environment - Humidity.** Ambient humidity (the humidity at the unit's installed location) shall be within the range: 10 to 95% (for controls, non-condensing). Air humidity (the humidity of the air passing through the unit) shall be within the range: 10 to 95% (for controls, non-condensing).

5.0 INSTALLATION REQUIREMENTS

In addition to the particular requirements given for the individual product, the following general requirements should be noted.

5.1 Where access to any part of equipment which moves, or can become electrically live are not prevented by the equipment panels or by fixed installation detail (e.g. ducting), then guarding to the appropriate standard must be fitted.

5.2 The electrical installation of the equipment must comply with the requirements of the relevant local electrical safety regulations.

5.3 For EMC all control and sensor cables should not be placed within 50mm or on the same metal cable tray as 230V switched live, lighting or power cables and any cables not intended for use with this product.

6.0 COMMISSIONING REQUIREMENTS

6.1 General pre-commissioning checks relevant to safe operation consist of the following:
Ensure that no foreign bodies are present within the fan or casing.
Check electrical safety e.g. Insulation and earthing.
Check guarding of system.
Check operation of Isolators/Controls.
Check fastenings for security.
Other commissioning requirements are given in the relevant product documentation.

7.0 OPERATIONAL REQUIREMENTS

7.1 Equipment access panels must be in place at all times during operation of the unit, and must be secured with the original fastenings.

7.2 If failure of the equipment occurs or is suspected then it should be taken out of service until a competent person can effect repair or examination. (Note that certain ranges of equipment are designed to detect and compensate for fan failure).

8.0 MAINTENANCE REQUIREMENTS

8.1 Specific maintenance requirements are given in the relevant product documentation.

8.2 It is important that the correct tools are used for the various tasks required.

8.3 If the access panels are to be removed for any reason the electrical supply to the unit must be isolated. A minimum period of two minutes should be allowed after electrical disconnection before access panels are removed. This will allow the impeller to come to rest.

8.4 **NB: Care should still be taken however since airflow generated at some other point in the system can cause the impeller to "windmill" even when power is not present.**

8.5 Care should be taken when removing and storing access panels in windy conditions.



FOR MORE INFORMATION

www.nuaire.co.uk

COMMERCIAL

www.nuaire.co.uk/commercial

Nuaire: A Trading Division of Polypipe

Western Industrial Estate | Caerphilly | CF83 1NA

t +44 (0)29 2085 8200 | f +44 (0)29 2085 8222 | e info@nuaire.co.uk

www.nuaire.co.uk

As part of our policy of continuous product development Nuaire reserves the right to alter specifications without prior notice.
Telephone calls may be recorded for quality and training purposes.