

DRI-365



Whole House Positive Input Ventilation Unit Installation Manual



1.0 SAFETY INFORMATION

- The provision of the electrical supply and the connection of the unit to the electrical supply must be carried out by a qualified electrician.
- Isolate from power supply before removing any covers. During installation / maintenance ensure all covers are fitted before switching on the mains supply.
- All-pole disconnection from the mains as shown in the wiring diagram must be incorporated within the fixed wiring and shall have a minimum contact separation of 3mm in accordance with latest edition of the wiring regulations.
- This unit must be earthed.
- Ducting must be securely fixed with screws to the spigot to prevent access to live parts. Duct runs terminating close to the fan must be adequately protected by suitable guards.
- This appliance should not be used by children or persons with reduced physical, sensory or mental capabilities or lack of experience and knowledge, unless they have been given supervision or instruction concerning the safe use of the appliance by a person responsible for their safety. Children shall not play with the appliance. Cleaning and user maintenance shall not be carried out by children.
- Precautions must be taken to avoid the back-flow of gases into the room from the open flue or gas or other fuel-burning appliances.

1.1 Symbols



GENERAL WARNING

Signifies a general warning regarding hazard specified by supplementary information.



ELECTRIC SHOCK

This unit must be completely electrically isolated before any panels are removed. Check mains supply and control connections.



ROTATING PARTS

This unit contains fast moving rotational parts which may start automatically. It is the sole responsibility of the installer to adequately guard these components.



REFER TO INSTRUCTION MANUAL

Read and understand the installation and maintenance manual before installing, operating or maintaining this product.

1.2 Important Information

This manual contains important information on the safe and appropriate assembly, transport, commissioning, operation, maintenance, disassembly and simple troubleshooting of the product.

While the product has been manufactured according to the accepted rules of current technology, there is still a danger of personal injury or damage to equipment if the following general safety instructions and the warnings contained in these instructions are not complied with.

- **Read these instructions completely and thoroughly before working with the product.**
- **Keep these instructions in a location where they are accessible to all users at all times.**
- **Always include the operating instructions when you pass the product on to third parties.**

1.3 Personal Protective Equipment

The following minimum Personal Protective Equipment (PPE) is recommended when interacting with Nuaire product:

- **Protective Steel Toed Shoes** - when handling heavy objects.
- **Full Finger Gloves (Marigold PU800 or equivalent)** - when handling sheet metal components.
- **Semi Fingerless Gloves (Marigold PU3000 3DO or equivalent)** - when conducting light work on the unit requiring tactile dexterity.
- **Safety Glasses** - when conducting any cleaning/cutting operation or exchanging filters.
- **Reusable Half Mask Respirators** - when replacing filters which have been in contact with normal room or environmental air.

Nuaire would always recommend a site specific risk assessment by a competent person to determine if any additional PPE is required.

2.0 INTRODUCTION

The unit is a unique low energy Positive Input Ventilation (PIV) unit. Unlike conventional PIV units which only draw in external air via the loft in a "cold roof", the unit is capable of drawing in external air from a roof location via an inlet spigot fitted with a low energy open/close damper.

It is not necessary for the home owner to program or operate the unit in any way, as the 365 is fully automatic and intelligently decides which location the fresh air will be supplied from.

If the loft temperature is below 24°C then the unit will take fresh air from the loft. If the loft temperature is above 24°C then cool fresh air will be taken from outside the dwelling. If the loft temperature is 19°C to 24°C and the house is cooler than this, then the unit goes into heat recovery mode. The unit will increase in speed and supply more air to the property.

The unit can be boosted to obtain maximum ventilation by the operation of a boost switch.

3.0 MECHANICAL INSTALLATION

Successful operation of the fan depends entirely upon the unit being installed strictly in accordance with these instructions. Please read through this guide in its entirety before commencing installation and follow step by step to ensure a satisfactory completion.

Installation must be completed by competent persons, in accordance with good industry practice and should conform to all governing and statutory bodies i.e. IEE, CIBSE, etc.

Isolate from power supply before removing any covers. During installation / maintenance ensure all covers are fitted before switching on the mains supply.

All-pole disconnection from the mains as shown in the wiring diagram must be incorporated within the fixed wiring and shall have a minimum contact separation of 3mm in accordance with latest edition of the wiring regulations.

Precautions must be taken to avoid the back-flow of gases into the room from the open flue of gas or other fuel-burning appliances.

This appliance should not be used by children or persons with reduced physical, sensory or mental capabilities or lack of experience and knowledge, unless they have been given supervision or instruction concerning the safe use of the appliance by a person responsible for their safety. Children shall not play with the appliance. Cleaning and user maintenance shall not be carried out by children.

CAUTION: In order to avoid a hazard due to inadvertent resetting of the thermal cut-out, this appliance must not be supplied through an external switching device, such as a timer, or connected to a circuit that is regularly switched on and off by the utility.

3.1 Loft Inspection

Check to ensure that the loft has adequate ventilation. There may be occasions where a loft is so well sealed that additional ventilation may have to be provided by the owner/occupier.

Ensure that all water tanks are covered and sealed.

Check that all water pipes are lagged.

Ensure that any extract fans are discharging to outside and not into the loft.

Check that the loft hatch is tightly sealed.

Ensure that all holes in the ceilings are sealed i.e. ceiling light fittings etc. A visual inspection of any flues or chimneys for leakage in the loft should be carried out by the installer. If any leakage points are found, or if there is any doubt at all, then the installer should advise the house owner/provider as soon as possible and seek instruction from them before proceeding with the installation.

3.2 Ceiling Diffuser Installation

3.2.1 Ceiling Diffuser Location

The diffuser has a unique air throw pattern and it is essential that it is located correctly in the central hallway in single storey properties or in the ceiling of the top floor landing on 2 or more storey dwellings. The diffuser discharges air evenly in all directions along the underside of the ceiling.

SMOKE ALARMS -It is also important to ensure that the diffuser is NOT placed within 1 metre of a smoke alarm.

Where a floor/room is more than 4.5m tall, the fan unit must be fitted with a 3 storey aluminium diffuser and requirements in section 5.2 followed.

If the diffuser cannot be repositioned, two sides of the diffuser must be closed off using the air dams supplied to encourage the air through the remaining open sides that faces at least 1.5 metres of unobstructed area away from the smoke alarm sensor.

Speed Setting	Minimum Distance Between Diffuser & Wall
1	100mm
2	155mm
3	400mm
4	625mm
5	850mm
6	1000mm

3.2.2 Directing Airflow

Air dams should be fitted as needed, to alter the direction of airflow required. Two air dams are supplied and will fit on any of the diffuser sides to guide airflow away from a smoke detector and/or obstructions.

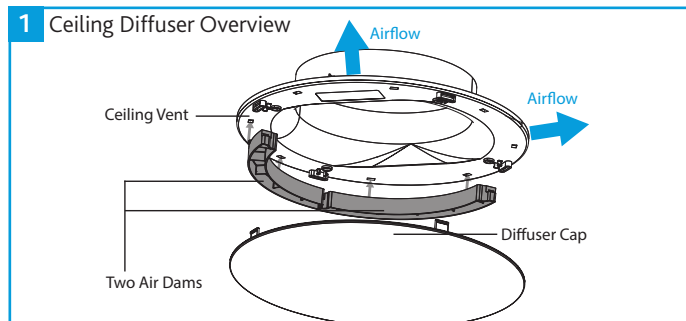

3.2.3 Mounting Ceiling Diffuser

To install the diffuser, use the tear-out template from the lid of the unit packaging and trace the shape onto the ceiling between two convenient joists. Once the shape has been cut out, position the ceiling vent by aligning the label on the ceiling vent with the narrowest point of the ellipse and secure it in place using the 4 screws and plugs provided.

Finally attach the diffuser cap to the frame using the four built-in press on clips provided.

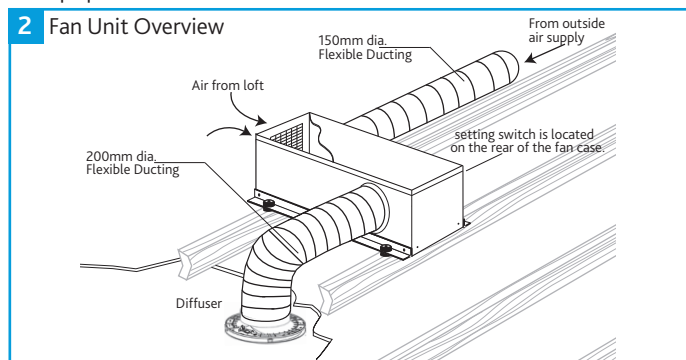

3.3 Fan Unit Installation

3.3.1 Mounting Fan Unit (Standard Configuration)

Connect the two 'L' shape fixing brackets to the long sides of the unit with the M5 screws (provided) then lower the unit with the "L" shape fixing brackets attached to the unit onto the joists. Mark 4 holes through the brackets so that the holes will be centrally positioned over a joist.

Locate anti-vibration mounts (supplied) above and below each bracket fixing joint hole and, using 4 suitable screws (not provided) and washers, fix the unit to the joists. **Do not over-tighten the fixings.**

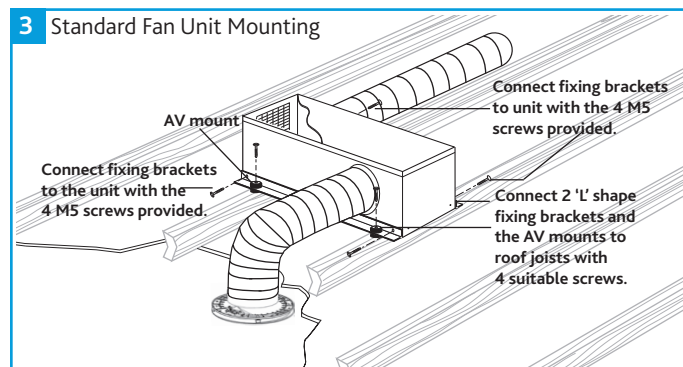

4 Anti-Vibration Mount Installation

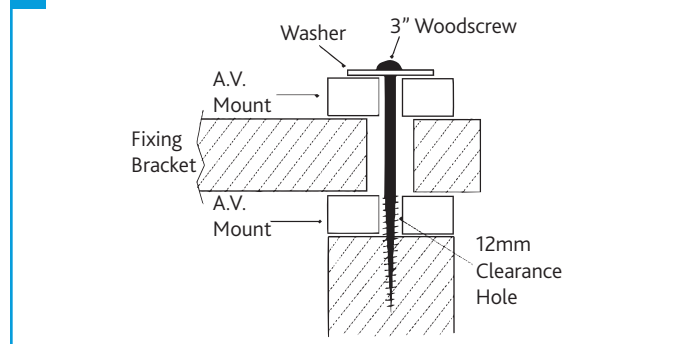

3.3.2 Mounting Fan Unit (Optional Configuration)

Using a similar procedure the two 'L' shape fixing brackets can also be mounted on the short sides of the DRI-365 unit if an alternative mounting position is required.

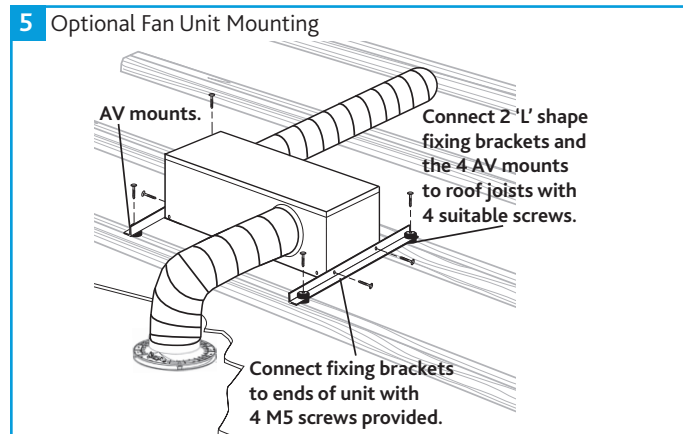

3.4 Air Intake & Ducting Connections

Any air intake terminal **MUST** be installed in accordance with appropriate regulation.

As a guide, the BS5440 series of British Standards deals with this issue and currently states that an air intake must be at a minimum distance of 300mm from a gas boiler balanced flue. Installers are advised to be aware of the requirements of this standard when installing 'through the wall' supply air ducting. Similarly, supply and extract air grilles should be at least 300mm apart.

As explained previously the unit is capable of drawing in external air from different roof locations via an air inlet spigot (see overleaf).

Air inlet locations are as follows:

- Soffit Installation: The soffit through a grille and ducting, supplied by others.
- Wall Installation: Wall grille and ducting, supplied by others.

The following installation materials, not supplied with the unit, can be purchased separately, direct from Nuair.

Tel: 02920 858500

E-mail: info@nuaire.co.uk

Kit Type	Part No.	Description
DRI365-SOFFITKIT	775229	128mm x 260mm soffit grille
	PVC933WH	3m length of 222mm x 90mm flexible PVC ducting for use on soffit inlets
	FLD1150	5m length of 150mm dia insulated ducting
	RDC150	150mm duct connector for connecting 222 x 90 flexible duct to 150mm duct
	777483	2m length insulated flexible ducting
	DT33	Qty 8 dynotie zip ties, used for connecting ducting to spigots
DRI365-WALLKIT	FLD1150	5m length of 150mm dia. Insulated ducting
	777483	2m length insulated flexible ducting.
	PVC604WH	Outlet grille
	PVC130-6WH	150mm telescopic pipe
	DT33	Qty 8 dynotie zip ties, used for connecting ducting to spigots

3.4.2 Wall Installation

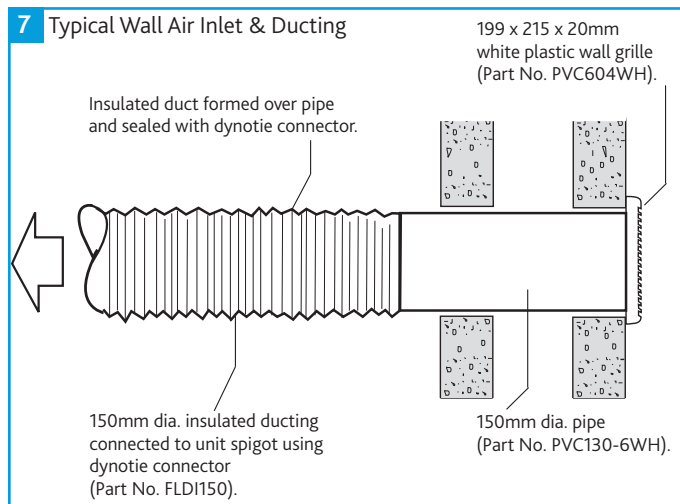

3.4.1 Soffit Installation

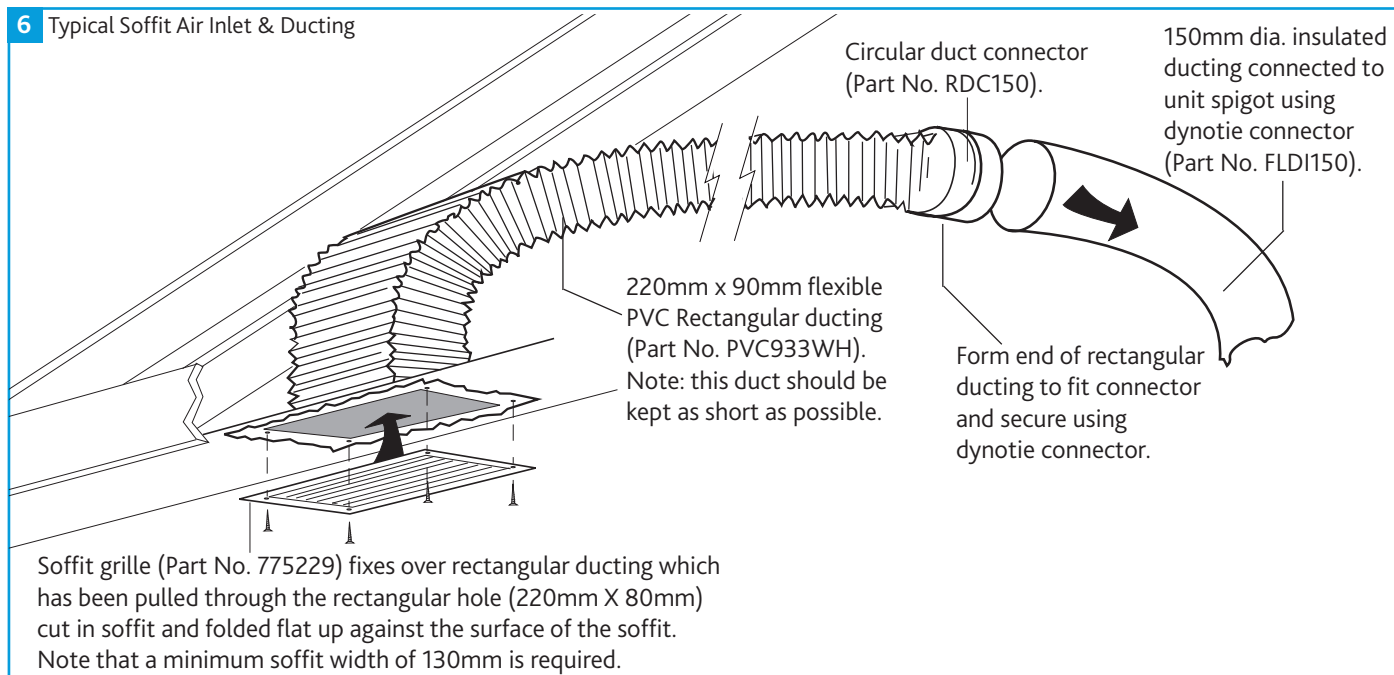

3.5 Remote Sensor

DRI-365 units are supplied with 15 metres of 2 core cable pre-wired and ready to connect to the Remote Sensor.

The Remote Sensor is used in conjunction with the units internal sensor to allow the system to operate in "Heat Recovery Mode".

The sensor is fitted with an LED indicator which is capable of providing various status information if required:

- **FLASHING RED** - after 5 years from commissioning to indicate that the filters need cleaning or replacement.
- **PERMANENT RED** - to indicate a failure.
- **GREEN** - to indicate when the system is in 'Heat Recovery Mode'.
- **AMBER** - which indicates normal operation.

If it is desired to disable the LED function completely the LED itself may be 'bent' over to one side in order to render it 'blind' to the user.

8 Remote Sensor

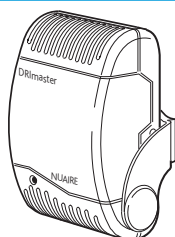

3.5.1 Remote Sensor Installation

For good EMC engineering practice, power supply output cables and any sensor cables should not be placed within 50mm of other cables or each other.

The Remote Temperature Sensor incorporates a clip-in fixing bracket which can be removed for easy fitting to a suitable surface.

- Select a suitable location for the sensor e.g. close to ceiling height in a bedroom or hallway BUT NOT WITHIN 3 METRES of the diffuser.
- Arrange the connecting cable in position. Leave approx. 75mm of the cable free at the mounting point to ease the connection of the cable.
- Carefully separate the sensor from the fixing bracket using a small screwdriver.
- Fix the bracket to the wall and arrange the end of the cable to fall through the slot cut in the bracket.
- Carefully separate the two sensor halves to reveal the wiring connection terminals.
- Feed the twin cable through the cut out rear half and connect the two wires to the terminals.
- Reassemble the sensor body halves.
- Clip the sensor body in the fixing bracket arms and adjust the sensor body to the desired position.

The remote sensor is connected to the circuit board via the supplied 2 core cable and into the connector labelled 'Remote Sensor' on the circuit board.

9 Remote Sensor Installation

15m sensor connection wire (pre-wired to unit).

Allow approx 75mm of wire through for fitting to the backplate.

Wire can be located behind a wall panel or fixed to wall surface.

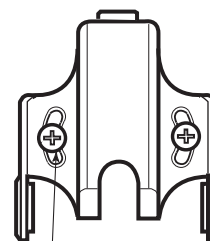
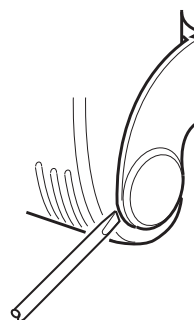
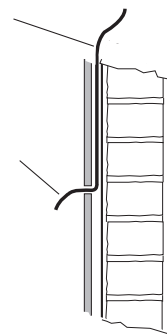

Bracket Fixing Screws

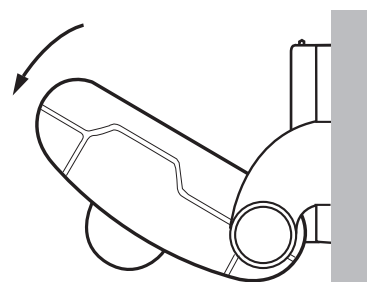
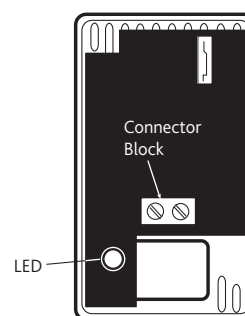

4.0 ELECTRICAL INSTALLATION

The electrical connection of the unit must be carried out by a qualified electrician.

4.1 Electrical Information

Voltage: 230V 1ph 50Hz
Consumption: 2W(min) 24W(max)
Fuse Size: 3A

4.2 Wiring

This unit **MUST** be earthed.

The three core cable from the mains power supply should be connected to a fixed wiring installation, via a fused isolator, in accordance with current IEE wiring regulations.

Isolate from power supply before removing any covers. During installation / maintenance ensure all covers are fitted before switching on the mains supply.

Before the unit is operational, additional wiring is necessary:

- A 230V single phase supply is required to be connected to the circuit board within the unit, via the electrical gland (supplied) on the side of the Drimaster365.
- A boost switch (supplied) is to be connected to the circuit board with two core cable (supplied), via the grommet at the front of the unit.
- The remote sensor (supplied) is to be connected to the circuit board with two core cable (supplied), via the grommet at the front of the unit.

5.0 CONTROLS

5.1 Fan Speed Adjustment

The unit has 6 air volume (speed) settings. The setting switch is located on the rear of the fan case. 6 speed indicator lights on the rear panel of the fan unit include LED's that, when illuminated, indicate the corresponding air volume for the unit.

For example, a one bedroom, one person bungalow recommended setting would be speed 1. A five bedroom, seven person detached house recommended setting would be speed 6. The installer would advise this on install.

On initial set up when power is connected the first 3 LED's will flash randomly for approximately 2 minutes and will then set at its default factory setting (speed 2). To select another speed setting simply press the reset button until the required setting is selected.

A boost switch (supplied) is to be connected to the circuit board within the unit with 2 core cable (supplied). This 2 core cable is to pass through the unit as shown opposite. The switch is to be located within the home for the householder to be able to boost the unit if required.

The unit air volume can be manually boosted to maximum speed by operation of the boost switch. This is to obtain maximum ventilation from the unit should the householder require it.

5.2 Smoke / Carbon Monoxide Alarm Automatic Shut Down

If the unit is required to switch off in the event of smoke/CO detection, alarms are available with separate relay bases from companies such as:

Kidde – www.kiddesafetyeurope.co.uk

Aico Ltd – www.aico.co.uk

This is a mandatory requirement for all units installed in a 3 Storey property.

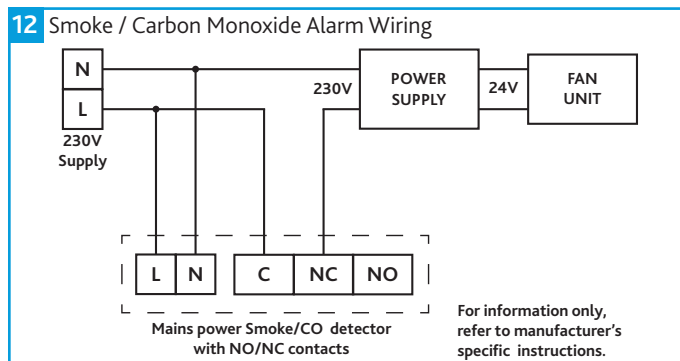
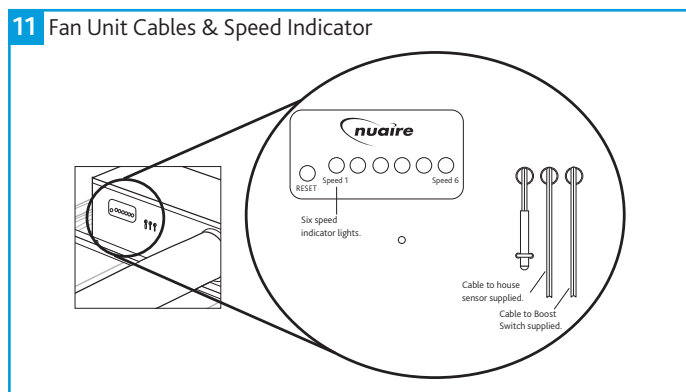
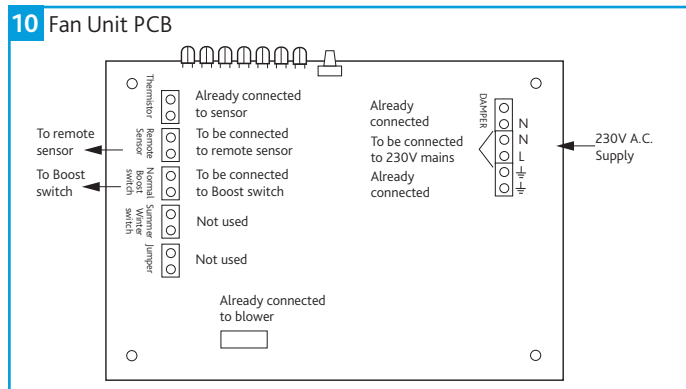

6.0 MAINTENANCE

It is important that maintenance checks are recorded and that the schedule is always adhered to, in all cases, the previous report should be referred to.

Isolate from power supply before removing any covers. During installation / maintenance ensure all covers are fitted before switching on the mains supply.

The unit does not require any maintenance other than a filter change and a check of electrical connections every 5 years, failure to do so may impair the performance and energy efficiency of this unit. New filters can be purchased direct from Nuair using the following code:

- 777389 (5 year filter).

Dust can occasionally accumulate through static, on the diffuser and the adjacent ceiling. This can be removed if required by vacuuming.

A clear distance of 500mm should be available above the unit to allow access for maintenance.

6.1 Filter Replacement

Once every 5 years the filter requires replacement. To replace the filter:

- Make sure the power to the unit is off.
- Open the lid of the fan unit by removing the 5 screws which hold the lid on.
- Remove the filter.
- Replace the filter.
- Replace and secure the lid.

7.0 FAQ

While very rare, issues with newly installed units can occur. Typically these issues can be easily solved by referring to the below table.

Symptom	Cause	Solution
Fan not running.	NO power to the unit (Display is NOT lit).	Ensure unit has not been switched off or that the local fuse has not blown.
	Software error - Power to the unit (Display is lit).	If electricity present, power off, wait and power on again – this may restart the unit.
	Fan failure - Power to the unit ('F' is flashing on display).	Fan has failed and a replacement unit is required.
	High loft temperature.	This is normal, see temperature control options.

8.0 WARRANTY

The 5 year warranty starts from the day of delivery and includes parts and labour for the first year. The remaining period covers replacement parts only.

This warranty is void if the equipment is modified without authorisation, is incorrectly applied, misused, disassembled, or not installed, commissioned and maintained in accordance with the details contained in this manual and general good practice.

The product warranty applies to the UK mainland and in accordance with Clause 14 of our Conditions of Sale. Customers purchasing from outside of the UK should contact Nuair International Sales office for further details.

Failure to maintain the unit as recommended will invalidate the warranty.

9.0 END-OF-LIFE AND RECYCLING

Ensure that Nuair product is made safe from any electrical / water / refrigerant supplies before dismantling commences. This work should only be undertaken by a qualified person in accordance with local authority regulations and guidelines, taking into account all site based risks.

Where possible Nuair use components which can be largely recycled when the product reaches its end-of-life:

- Fans, motors, controls, actuators, cabling and other electrical components can be segregated into WEEE recycling streams.
- Sheet metal parts, aluminium extrusion, heating/cooling coils and other metallic items can be segregated and fully recycled.
- EPP, plastic ducting, nylon corner pieces, plastic heat exchangers, packaging material and other plastic components can be segregated into mixed plastic and widely recycled.
- Cardboard packaging, wood, used filters and other paper components can be largely recycled or fully processed in energy from waste centres.
- Remaining Items can be further segregated and processed in accordance with the zero waste hierarchy. Please call After Sales Support for further information on items not listed above.

10.0 AFTER SALES AND REPLACEMENT PARTS

For technical assistance or further product information, including spare parts and replacement components, please contact the After Sales Department.

If ordering spares please quote the serial number of the unit together with the part number, if the part number is not known please give a full description of the part required. The serial number will be found on the identification plate attached to the unit casing.

Additionally a QR code linking directly to the Nuair Ltd. website is located behind the diffuser plate and can be used to order spare parts and replacement components.

Telephone 02920 858 400
aftersales@nuair.co.uk

Technical or commercial considerations may, from time to time, make it necessary to alter the design, performance and dimensions of equipment and the right is reserved to make such changes without prior notice.

