



Long Cased Axial Fans

High Temperature 300°C / 400°C for 2 hours

Installation Manual



1.0 SAFETY INFORMATION

- The provision of the electrical supply and the connection of the unit to the mains must be carried out by a qualified electrician.
- Isolate from power supply before removing any covers. During installation / maintenance ensure all covers are fitted before switching on the mains supply.
- All-pole disconnection from the mains as shown in the wiring diagram must be incorporated within the fixed wiring and shall have a minimum contact separation of 3mm in accordance with latest edition of the wiring regulations.
- This unit must be earthed.
- Ducting must be securely fixed with screws to the spigot to prevent access to live parts. Duct runs terminating close to the fan must be adequately protected by suitable guards.
- Precautions must be taken to avoid the back-flow of gases into the room from the open flue of gas or other fuel-burning appliances.
- This appliance should not be used by children or persons with reduced physical, sensory or mental capabilities or lack of experience and knowledge, unless they have been given supervision or instruction concerning the safe use of the appliance by a person responsible for their safety. Children shall not play with the appliance. Cleaning and user maintenance shall not be carried out by children.

1.1 Hazard Symbols



GENERAL WARNING

Signifies a general warning regarding hazard specified by supplementary information.



ELECTRIC SHOCK

This unit must be completely electrically isolated before any panels are removed. Check mains supply and control connections.



ROTATING PARTS

This unit contains fast moving rotational parts which may start automatically. It is the sole responsibility of the installer to adequately guard these components.



REFER TO INSTRUCTION MANUAL

Read and understand the installation and maintenance manual before installing, operating or maintaining this product.

1.2 Important Information

This manual contains important information on the safe and appropriate assembly, transport, commissioning, operation, maintenance, disassembly and simple troubleshooting of the product.

While the product has been manufactured according to the accepted rules of current technology, there is still a danger of personal injury or damage to equipment if the following general safety instructions and the warnings contained in these instructions are not complied with.

- **Read these instructions completely and thoroughly before working with the product.**
- **Keep these instructions in a location where they are accessible to all users at all times.**
- **Always include the operating instructions when you pass the product on to third parties.**

1.3 Personal Protective Equipment

The following minimum Personal Protective Equipment (PPE) is recommended when interacting with Nuaire product:

- **Protective Steel Toed Shoes** - when handling heavy objects.
- **Full Finger Gloves (Marigold PU800 or equivalent)** - when handling sheet metal components.
- **Semi Fingerless Gloves (Marigold PU3000 3DO or equivalent)** - when conducting light work on the unit requiring tactile dexterity.
- **Safety Glasses** - when conducting any cleaning/cutting operation or exchanging filters.
- **Reusable Half Mask Respirators** - when replacing filters which have been in contact with normal room or environmental air.

Nuaire would always recommend a site specific risk assessment by a competent person to determine if any additional PPE is required.

2.0 INTRODUCTION

Nuaire's Axus range of Long Cased Axial Flow Fans with one off high temperature operation are produced in sixteen case sizes from 315mm diameter to 1600mm diameter with duties up to 65m³/s.

Impellers are manufactured in aluminium alloy or steel. These high performance impellers have been selected to provide a range of units that will suit your specific requirements. Note: Nuaire will not accept responsibility for damaged units when unauthorised personnel have altered blade angles.

The fans are available for three phase operation only.

The units are designed for:

S1 DUTY Day to day operation and in the event of fire a one off emergency use.

The range has been designed for ease of installation into new or existing ductwork systems. The optional supporting brackets can be located any where around the circumference of the flange allowing the fan to be installed in any mounting plane. Fan units are suitable for internal and external use.

Anti-vibration Mounting kits are available as an ancillary. A full range of additional ancillaries is available including:

Matching flanges, matching attenuators, mounting brackets, flexible connectors, inlet cones and backdraught dampers.

EN12101-3 compliant, refer to EC certificate of conformity, 10086-CPR-672476.

2.1 Code Description:

AX 63 AD - 2 1 A 7 + 13M
 | | | | | | | | | |
 1 2 3 4 5 6 7 8 9 10

- | | |
|---------------------------|--|
| 1. Range: | Long Case Axial Fans |
| 2. Impeller Size (cm): | 31 to 160 |
| 3. Impeller Reference: | Contact Nuaire |
| 4. Guide Vanes: | * = Guide Vanes
- = No Guide Vanes |
| 5. Motor Poles: | 2, 4, 6 or 8 |
| 6. Blade Angle Reference: | Contact Nuaire |
| 7. Impeller Material: | A = Aluminium
S = Steel |
| 8. Motor Type: | 7 = Three Phase 300°C/2hr
8 = Three Phase 400°C/2hr |
| 9. Speed Control: | + = Must Be VSD Controlled
- = No Speed Control |
| 10. Further Options: | Contact Nuaire |

3.0 DELIVERY & HANDLING

All equipment is inspected prior to despatch and leaves the factory in good condition. Upon receipt of the equipment an inspection should be made and any damage indicated on the delivery note. Particulars of damage and/or incomplete delivery should be endorsed by the driver delivering the goods before offloading by the purchaser.

No responsibility will be accepted for damage sustained during the offloading from the vehicle or on the site thereafter. All claims for damage and/or incomplete delivery must be reported to Nuaire within two days of receipt of the equipment.

The fan impeller is carefully balanced and centralised in the fan case, it is therefore essential that great care is exercised when handling the unit. Check the weight on the rating plate details before attempting to lift and always use a spreader as shown (Figure 1), never pass lifting slings through the impeller.

Care must be taken when handling a unit/attenuator assembly fitted with flexible connectors as the connectors can be distorted or damaged.

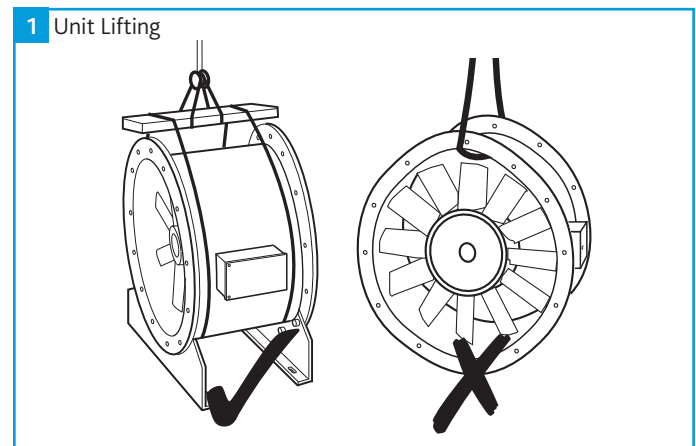

4.0 INSTALLATION

Installation must be carried out by competent personnel, in accordance with good industry practice, the appropriate authority and in conformance with all statutory and governing regulations e.g. IEE, CIBSE, COSHH, HVCA, ATEX, BSI & EN standards etc.

Before commencing installation check that all material, including optional ancillaries are available to complete the installation. Every unit is tested and serialised at works and a test certificate produced, the details recorded on the fan side rating plate should also be referred to before handling and installation.

Any damages or deviations should be immediately reported to the seller/supplier/agent quoting the order and product details from the product rating plate.

Do not reverse impeller direction of operation as performance of the unit is drastically reduced. Do not alter the blade angle of impeller without the permission of Nuairé, doing so may invalidate your warranty.

Isolation - Before commencing work, make sure that the unit, switched live and Nuairé controls are electrically isolated from the mains supply.

The list below states the main characteristics of the AXUS axial fan range certified for operation at 300°C for 2 hours. The unit:

- Is thermally uninsulated.
- May be located in smoke reservoir and non-smoke reservoir applications.
- Is dual purpose i.e. suitable for day-to-day operation and one-off emergency use.
- Suitable for mounting in horizontal, intermediate, or vertical orientation.
- Flow A, motor-impeller, and Flow B, impeller-motor operation.

The list below states the main characteristics of the AXUS axial fan range certified for operation at 400°C for 2 hours. The unit:

- Is thermally uninsulated.
- May be located in smoke reservoir and non-smoke reservoir applications.
- Is dual purpose i.e. suitable for day-to-day operation and one-off emergency use.
- Suitable for mounting in horizontal, intermediate, or vertical orientation.
- Flow A, motor-impeller, and Flow B, impeller-motor operation.

4.1 Mechanical Installation

Rotate the fan impeller by hand to ensure free and smooth rotation and that no transit or handling damage has occurred, observe the direction of flow/direction of rotation arrow and ensure that:

- **All optional accessories such as support brackets, attenuators, inlet cones, guards, flexible connectors etc. are assembled to the fan.**
- **AV mounts isolate the fan only. Attenuators, backdraught dampers and other 'significant mass' accessories should form part of the fixed ductwork after the flexible connection.**
- **The optional support brackets are correctly fitted, at any position around the circumference, but suit the installation plane.**
- **External termination box is accessible to the electrician.**
- **When offering the fan to the ducted system that both inlet and outlet connections are perfectly aligned.**
- **In order to ensure performance is as stated, a minimum distance of twice the fan diameter is required between the appliance and any bends in the ductwork.**

4.1.1 Horizontal on Floor or Supported from Wall etc.

Optional resilient mountings should be attached to the unit mounting brackets at this stage. If the unit is supported from a wall, supporting brackets should be used. Position and align the unit with the ductwork in both horizontal and vertical planes and pack height under mounting feet if necessary.

Attenuators, anti-back draught dampers form part of the fixed ductwork after the flexible connectors.

4.1.2 Suspended Horizontally or Vertically

Anti-Vibration (A.V.) mounts must be arranged so that they are used in **compression** only. A suspended steel under frame would be necessary (by others) to support the unit, standing on A.V. mounts.

4.2 Electrical Installation

4.2.1 Motors

Motors are totally enclosed and protected to IP55 (Dust and low pressure water jets). Motors comply with BS5000, EN600034 and IEC34-1.

The motors have sealed for life ball bearings in units up to 132mm frame size. For frame sizes of 160mm and above motors are of the re-greaseable type. Enclosures are to IP55 with class H insulation. Motors are tested in accordance with EN12101-3.

Please note the requirements for maintenance of the motor. Failure to comply with the recommendations will invalidate any warranty claim.

4.2.2 Wiring

Electrical supply wiring connection is to an externally mounted terminal box on the case exterior. The box is pre-wired to the motor with heat resisting cable.

4.2.3 Connection Details

Check that the voltage full load and starting current on the fan rating label is suitable for your supply. Units for external use require weatherproof conduit and glands.

Single speed motors below 4kW

Single speed motors below 4kW are suitable for Direct On Line starting only.

Single speed motors 4kW and above

Single speed motors 4kW and above are supplied with Star / Delta capability but Direct On Line starting is recommended as the simplest means for emergency equipment operation.

Two speed motors

Two speed motors are supplied TAP or PAM single winding or Dual Wound. All two speed types are designed for Direct On Line starting on both speeds unless otherwise specified.

4.3 Wiring Diagrams

4.3.1 Single Speed - Three Phase (3kw and below)

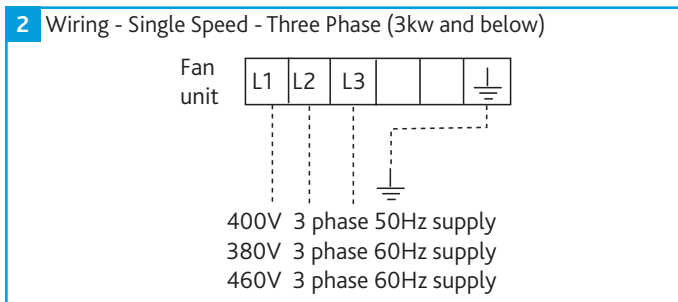

4.3.2 Two Speed - Dual Wound Motor (D.O.L. Starting Both Speeds) - Three Phase

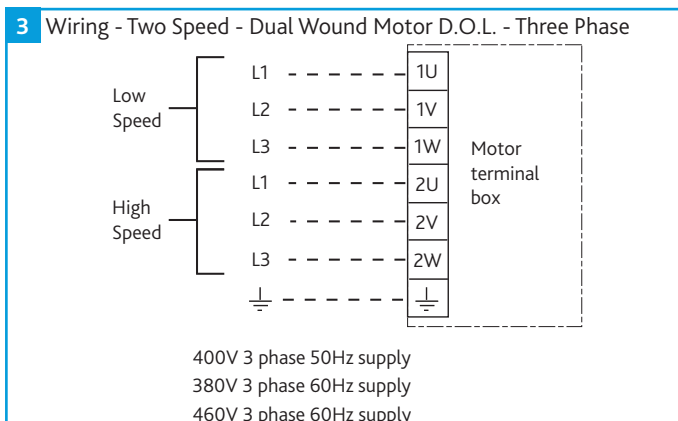

4.3.3 D.O.L. Starting (3kW and below) - Three Phase

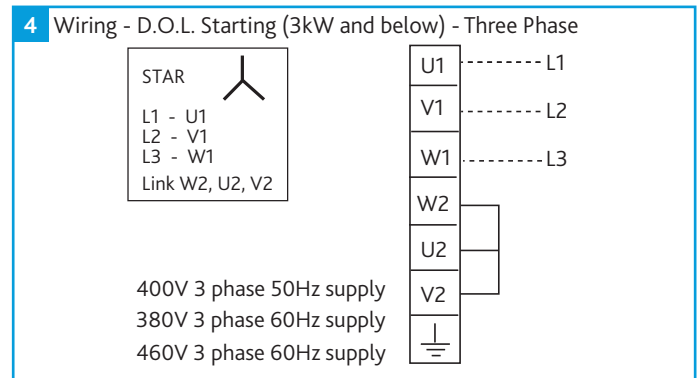

4.3.4 Star / Delta Starter (4kW and above) - Three Phase

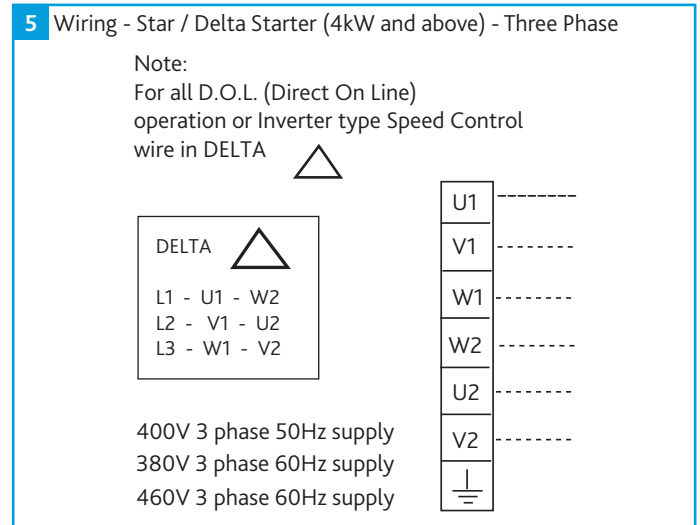

4.3.5 Electronic Speed Control - Three Phase

Total length of motor leads should not exceed 50 metres. If a screened cable is used, maximum length should be 25 metres. Consult our Technical Department if you wish to use longer leads.

Inverters are configured to suit specific fans and control applications as described on the Customer Order, free of charge.

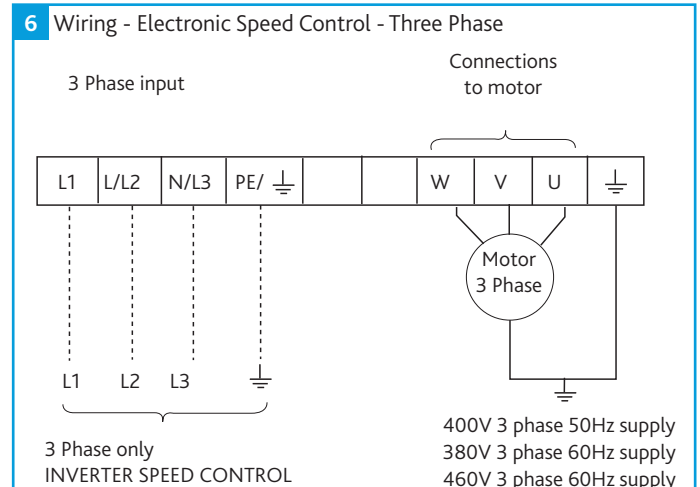

4.4 Start-Up Procedure

Ensure that the impeller rotation follows the label arrow indicator on the casing. Should the direction be incorrect on three phase units, reverse any two of the supply leads. Care should be taken to set correct rotation as incorrect rotation may result in damage to the motor. Equipment should be run for approx. 30 minutes to ensure correct operation. If any fault occurs, the equipment should be switched off. Do not re-start until the fault has been rectified.

For specialist connections not shown always refer to the wiring diagram supplied with the unit. In the event of query or uncertainty contact NUAIRE directly before any connection is made.

4.5 Optional Inverter Control for F300/2 Axis Range

High temperature Axis fans F300 Series have been tested with frequency converters to BS EN 12101-3:2015, and may be used with suitable frequency converters under emergency fire mode conditions providing they are operated at full speed and are selected to meet the parameters described in the table below.

Test parameters used in / derived from test series - ref C.6.2 (n)

Test Parameter	Result
Inverter Type	PWM
Filters Fitted	NO
Switching Frequency	4 kHz
Ramp Up Time	30 seconds
Maximum Peak Voltage (Vmax)	156
Maximum Peak To Peak Voltage (Vp)	436
Maximum Voltage Rise $du/dt = 0.8Vp/dt$ (V/nS)	1.659

5.0 SPECIFIC COMMISSIONING AND SERVICING REQUIREMENTS

300°C for 2 hours / 400°C for 2 hours Motors for Smoke Extract Fans

Exposure temperature/time: 300°C for 2 hours / 400°C for 2 hours

These motors are used to provide a SAFETY FUNCTION for people in the event of fire in public premises or in the home: they are therefore subject to strict constraints concerning their operating and maintenance.

Operating Constraints

- i. Check on the nameplate that the selected motor corresponds to the maximum exposure temperature and duration.
- ii. Non ventilated motors MUST be placed in the airflow from the driven fan. Ventilated motors can be placed outside the flow.
- iii. AFTER THE MOTOR HAS BEEN SUBJECTED TO ONE EMERGENCY DUTY OPERATION, IT MUST BE REPLACED.
- iv. With variable speed control. Ensure that the maximum speed never exceeds the speed of the motor supplied by the mains and that the delivered power corresponds to the previous definitions. The motor should be equipped with PTC thermistors connected to the protection system during S1 duty and switched off during S2 duty (operation during an emergency).

These qualifications ensure the qualification of the driven fan by the manufacturer.

Maintenance Constraints

Regular service visits must be performed on the installation AT LEAST EVERY 6 MONTHS, incorporating the following checks:

i. Checking the insulation resistance ($R > 100$ MOhms, 500V DC)

- If the drain holes are blocked, open them to eliminate any accumulated condensation.
- If $R < 100$ MOhms, dry the stator in an oven and check the insulation resistance. If the fault persists, replace the stator.
- The stator must be replaced 5 years after installation or after 20,000 hours of operation.

ii. Cooling check

- Ensure there is no dust or grease in the entire ventilation circuit (housing fins, motor cover/fan if fitted driven fan).
- Ensure the motor runs normally when switched on for a few minutes.

iii. Bearing check (C3 or C4 play)

Run the motor during each maintenance visit. When the motor is cold, a high level of noise is caused by the texture of the grease. This does not indicate a bearing fault.

S2 duty only:

The bearings must be replaced by an identical type every 5 years. Ensure the motor runs normally when switched on for a few minutes.

S1 duty and Emergency in S2 duty:

a) Permanently greased bearings.

300°C / 400°C range; replace on 2 pole motors after 10,000 hours of operation and on motors with 4 poles or more after 20,000 hours.

b) Re-greaseable bearings

The information on the motor nameplates must be strictly respected (grease quantity, grease quality and re-greasing frequency). The bearings must be replaced after 20,000 hours of operation.

6.0 MAINTENANCE

It is important that maintenance checks are recorded and that the schedule is always adhered to, in all cases, the previous report should be referred to.

6.1 Routine Maintenance

- Clean all areas of unit of dust or fibres and treat any areas of corrosion, including lifting lugs / eye bolts.
- Check all areas and ensure no damage is present on units i.e. impeller cracked, fan cowl bent, foot cracked etc.
- Check all access doors for leakage and if necessary locks should be adjusted and any replacement gasket materials should be replaced as required.
- Check insulation resistance is adequate, it is imperative this is checked after any prolonged shut down period.
- Check all fasteners and tighten if necessary.
- Ensure no excessive vibration.

6.2 Every 3 Months

- Check sealing of motor and gland plate is in good condition.

6.3 Annually

- Thoroughly inspect the unit and its components for corrosion, acting immediately to treat/restore any damaged areas.
- Check all cables are in good condition and all electrical terminals within the unit are tight.
- Check all earth connections.
- Check all cables are in good condition.
- Check bearing condition and if necessary re-grease bearings for 160 motor frames and larger.

6.4 Motor Repair

Due to unit certification EN12101-3 and in compliance with the construction products directive, the motor must be returned to the motor manufacturer for replacement.

7.0 WARRANTY

The 3 year warranty starts from the day of delivery and includes parts and labour for the first year. The remaining period covers replacement parts only.

This warranty is void if the equipment is modified without authorisation, is incorrectly applied, misused, disassembled, or not installed, commissioned and maintained in accordance with the details contained in this manual and general good practice.

The product warranty applies to the UK mainland and in accordance with Clause 14 of our Conditions of Sale. Customers purchasing from outside of the UK should contact Nuaire International Sales office for further details.

Failure to maintain the unit as recommended will invalidate the warranty.

8.0 END-OF-LIFE AND RECYCLING

Where possible Nuaire use components which can be largely recycled when the product reaches its end-of-life:

- Fans, motors, controls, actuators, cabling and other electrical components can be segregated into WEEE recycling streams.
- Sheet metal parts, aluminium extrusion, heating/cooling coils and other metallic items can be segregated and fully recycled.
- Cardboard packaging, wood, used filters and other paper components can be largely recycled or fully processed in energy from waste centres.
- Remaining items can be further segregated for energy from waste centres or, as a last resort, sent to landfill. Please call After Sales Support for further information on items not listed above.

Ensure that Nuaire product is made safe from any electrical / water / refrigerant supplies before dismantling commences. This work should only be undertaken by a qualified person in accordance with local authority regulations and guidelines, taking into account all site based risks.

9.0 AFTER SALES AND REPLACEMENT PARTS

For technical assistance or further product information, including spare parts and replacement components, please contact the After Sales Department.

If ordering spares please quote the serial number of the unit together with the part number, if the part number is not known please give a full description of the part required. The serial number will be found on the identification plate attached to the unit casing.

Telephone 02920 858 400
aftersales@nuaire.co.uk

Technical or commercial considerations may, from time to time, make it necessary to alter the design, performance and dimensions of equipment and the right is reserved to make such changes without prior notice.

EU DECLARATION OF INCORPORATION AND INFORMATION FOR SAFE INSTALLATION, OPERATION AND MAINTENANCE

We declare that the machinery named below is intended to be assembled with other components to constitute a system of machinery. All parts except for moving parts requiring the correct installation of safety guards comply with the essential requirements of the Machinery Directive. The machinery shall not be put into service until the system has been declared to be in conformity with the provisions of the EC Machinery Directive.

Product: AXUS AXIAL FAN
Type: AX
Relevant EU Council Directives: 2006/42/EC (MACHINERY DIRECTIVE)

Applied EU Harmonised Standards: EN 60204-1:2006+A1:2009+AC:2010;
 EN ISO 12100:2010; EN ISO 13857:2008;
 EN ISO 9001:2015

Signature of manufacture representatives:

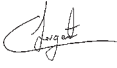
Name:	Position:	Date:
1) A. Thomas 	Technical Director	06. 08. 21
2) C. Sargent 	Manufacturing Director	06. 08. 21

Basis of Self Attestation: BS EN ISO 9001, BSI Cert No. FM 665203

Nuaire: A Trading Division of Polypipe, Western Industrial Estate, Caerphilly, CF83 1NA.

EU Authorised Representative: Eurolink Europe Compliance Limited, 25 Herbert Place, Dublin D02 AY86, Republic of Ireland.

All standards used were current and valid at the date of signature.

INFORMATION FOR SAFE INSTALLATION, OPERATION AND MAINTENANCE OF NUAIRE VENTILATION EQUIPMENT

To comply with EC Council Directives 2014/30/EU (EMC), 2014/35/EU (Low Voltage Directive). To be read in conjunction with the relevant product documentation (see 2.1)

1.0 GENERAL

1.1 The equipment referred to in this Declaration of Incorporation is supplied by Nuaire to be assembled into a ventilation system which may or may not include additional components. The entire system must be considered for safety purposes and it is the responsibility of the installer to ensure that all of the equipment is installed in compliance with the manufacturers recommendations and with due regard to current legislation and codes of practice.

2.0 INFORMATION SUPPLIED WITH THE EQUIPMENT

2.1 Each item of equipment is supplied with a set of documentation which provides the information required for the safe installation and maintenance of the equipment. This may be in the form of a Data sheet and/or Installation and Maintenance instruction.

2.2 Each unit has a rating plate attached to its outer casing. The rating plate provides essential data relating to the equipment such as serial number, unit code and electrical data. Any further data that may be required will be found in the documentation.

If any item is unclear or more information is required, contact Nuaire.

2.3 Where warning labels or notices are attached to the unit the instructions given must be adhered to.

3.0 TRANSPORTATION, HANDLING AND STORAGE

3.1 Care must be taken at all times to prevent damage to the equipment. Note that shock to the unit may result in the balance of the impeller being affected.

3.2 When handling the equipment, care should be taken with corners and edges and that the weight distribution within the unit is considered. Lifting gear such as slings or ropes must be arranged so as not to bear on the casing.

3.3 Equipment stored on site prior to installation should be protected from the weather and steps taken to prevent ingress of contaminants.

4.0 OPERATIONAL LIMITS

4.1 It is important that the specified operational limits for the equipment are adhered to e.g. operational air temperature, air borne contaminants and unit orientation.

4.2 Where installation accessories are supplied with the specified equipment e.g. wall mounting brackets. They are to be used to support the equipment only. Other system components must have separate provision for support.

4.3 Flanges and connection spigots are provided for the purpose of joining to duct work systems. They must not be used to support the ductwork.

4.4 **Local Environment - Humidity.** Ambient humidity (the humidity at the unit's installed location) shall be within the range: 10 to 95% (for controls, non-condensing).
 Air humidity (the humidity of the air passing through the unit) shall be within the range: 10 to 95% (for controls, non-condensing).

5.0 INSTALLATION REQUIREMENTS

In addition to the particular requirements given for the individual product, the following general requirements should be noted.

5.1 Where access to any part of equipment which moves, or can become electrically live are not prevented by the equipment panels or by fixed installation detail (e.g. ducting), then guarding to the appropriate standard must be fitted.

5.2 The electrical installation of the equipment must comply with the requirements of the relevant local electrical safety regulations.

5.3 For EMC all control and sensor cables should not be placed within 50mm or on the same metal cable tray as 230V switched live, lighting or power cables and any cables not intended for use with this product.

6.0 COMMISSIONING REQUIREMENTS

6.1 General pre-commissioning checks relevant to safe operation consist of the following:
 Ensure that no foreign bodies are present within the fan or casing.
 Check electrical safety e.g. Insulation and earthing.
 Check guarding of system.
 Check operation of Isolators/Controls.
 Check fastenings for security.
 Other commissioning requirements are given in the relevant product documentation.

7.0 OPERATIONAL REQUIREMENTS

7.1 Equipment access panels must be in place at all times during operation of the unit, and must be secured with the original fastenings.

7.2 If failure of the equipment occurs or is suspected then it should be taken out of service until a competent person can effect repair or examination (Note that certain ranges of equipment are designed to detect and compensate for fan failure).

8.0 MAINTENANCE REQUIREMENTS

8.1 Specific maintenance requirements are given in the relevant product documentation.

8.2 It is important that the correct tools are used for the various tasks required.

8.3 If the access panels are to be removed for any reason the electrical supply to the unit must be isolated.

8.4 A minimum period of two minutes should be allowed after electrical disconnection before access panels are removed. This will allow the impeller to come to rest.
NB: Care should still be taken however since airflow generated at some other point in the system can cause the impeller to "windmill" even when power is not present.

8.5 Care should be taken when removing and storing access panels in windy conditions.

UK DECLARATION OF INCORPORATION AND INFORMATION FOR SAFE INSTALLATION, OPERATION AND MAINTENANCE

We declare that the machinery named below is intended to be assembled with other components to constitute a system of machinery. All parts except for moving parts requiring the correct installation of safety guards comply with the essential requirements of the Machinery Directive. The machinery shall not be put into service until the system has been declared to be in conformity with the provisions of the EC Machinery Directive.

Product: AXUS AXIAL FAN
Type: AX
Relevant UK Council Directives: 2008 No. 1597, The Supply of Machinery (Safety) Regulations 2008;

Applied UK Harmonised Standards: BS EN 60204-1:2006+A1:2009+AC:2010; BS EN ISO 12100:2010; BS EN ISO 13857:2008; BS EN ISO 9001:2015

Signature of manufacture representatives:

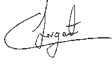
Name:	Position:	Date:
1) A. Thomas 	Technical Director	06. 08. 21
2) C. Sargent 	Manufacturing Director	06. 08. 21

Basis of Self Attestation: BS EN ISO 9001, BSI Cert No. FM 665203

Nuaire: A Trading Division of Polypipe, Western Industrial Estate, Caerphilly, CF83 1NA.

All standards used were current and valid at the date of signature.

INFORMATION FOR SAFE INSTALLATION, OPERATION AND MAINTENANCE OF NUAIRE VENTILATION EQUIPMENT

To comply with UK Regulations: The Supply of Machinery (Safety) Regulations 2008 and Electromagnetic Compatibility Regulations 2016. To be read in conjunction with the relevant product documentation (see 2.1)

1.0 GENERAL

1.1 The equipment referred to in this Declaration of Incorporation is supplied by Nuaire to be assembled into a ventilation system which may or may not include additional components. The entire system must be considered for safety purposes and it is the responsibility of the installer to ensure that all of the equipment is installed in compliance with the manufacturers recommendations and with due regard to current legislation and codes of practice.

2.0 INFORMATION SUPPLIED WITH THE EQUIPMENT

2.1 Each item of equipment is supplied with a set of documentation which provides the information required for the safe installation and maintenance of the equipment. This may be in the form of a Data sheet and/or Installation and Maintenance instruction. Each unit has a rating plate attached to its outer casing. The rating plate provides essential data relating to the equipment such as serial number, unit code and electrical data. Any further data that may be required will be found in the documentation. If any item is unclear or more information is required, contact Nuaire.

2.2 Where warning labels or notices are attached to the unit the instructions given must be adhered to.

3.0 TRANSPORTATION, HANDLING AND STORAGE

3.1 Care must be taken at all times to prevent damage to the equipment. Note that shock to the unit may result in the balance of the impeller being affected.

3.2 When handling the equipment, care should be taken with corners and edges and that the weight distribution within the unit is considered. Lifting gear such as slings or ropes must be arranged so as not to bear on the casing.

3.3 Equipment stored on site prior to installation should be protected from the weather and steps taken to prevent ingress of contaminants.

4.0 OPERATIONAL LIMITS

4.1 It is important that the specified operational limits for the equipment are adhered to e.g. operational air temperature, air borne contaminants and unit orientation.

4.2 Where installation accessories are supplied with the specified equipment e.g. wall mounting brackets. They are to be used to support the equipment only. Other system components must have separate provision for support.

4.3 Flanges and connection spigots are provided for the purpose of joining to duct work systems. They must not be used to support the ductwork.

4.4 **Local Environment - Humidity.** Ambient humidity (the humidity at the unit's installed location) shall be within the range: 10 to 95% (for controls, non-condensing). Air humidity (the humidity of the air passing through the unit) shall be within the range: 10 to 95% (for controls, non-condensing).

5.0 INSTALLATION REQUIREMENTS

In addition to the particular requirements given for the individual product, the following general requirements should be noted.

5.1 Where access to any part of equipment which moves, or can become electrically live are not prevented by the equipment panels or by fixed installation detail (e.g. ducting), then guarding to the appropriate standard must be fitted.

5.2 The electrical installation of the equipment must comply with the requirements of the relevant local electrical safety regulations.

5.3 For EMC all control and sensor cables should not be placed within 50mm or on the same metal cable tray as 230V switched live, lighting or power cables and any cables not intended for use with this product.

6.0 COMMISSIONING REQUIREMENTS

6.1 General pre-commissioning checks relevant to safe operation consist of the following:
 Ensure that no foreign bodies are present within the fan or casing.
 Check electrical safety e.g. Insulation and earthing.
 Check guarding of system.
 Check operation of Isolators/Controls.
 Check fastenings for security.

6.2 Other commissioning requirements are given in the relevant product documentation.

7.0 OPERATIONAL REQUIREMENTS

7.1 Equipment access panels must be in place at all times during operation of the unit, and must be secured with the original fastenings.

7.2 If failure of the equipment occurs or is suspected then it should be taken out of service until a competent person can effect repair or examination (Note that certain ranges of equipment are designed to detect and compensate for fan failure).

8.0 MAINTENANCE REQUIREMENTS

8.1 Specific maintenance requirements are given in the relevant product documentation.

8.2 It is important that the correct tools are used for the various tasks required.

8.3 If the access panels are to be removed for any reason the electrical supply to the unit must be isolated.

8.4 A minimum period of two minutes should be allowed after electrical disconnection before access panels are removed. This will allow the impeller to come to rest.

NB: Care should still be taken however since airflow generated at some other point in the system can cause the impeller to "windmill" even when power is not present.

8.5 Care should be taken when removing and storing access panels in windy conditions.