

AXUS SVT2

300°C for 2hr

High Temperature Impulse Axial Fans Installation and Maintenance

CE The EMC Directive
2004/108/EC
The Low Voltage
directive
2006/95/EC

Introduction

The Nuairé SVT2 impulse unit comprises a high temperature axial fan with specially designed inlet and outlet attenuators which, along with the fan unit, are encased in a Galvanised steel acoustic enclosure.

Fan Coding Descriptions

SVT2 - 1 (A-E)
1 2 3

1. AXUS Impulse fan
2. Case size
3. Impeller blade angle

The Nuairé SVT2 unit comprising fan/motor assembly, and inlet & outlet silencers shall be certified for high temperature operation at 300°C for 2 hours, the range shall have been type tested to EN12101-3.

The units shall be either 2 speed or inverter driven providing, low speed for day to day environmental ventilation and one off operation for emergency ventilation (SI duty). They shall also be suitable for reversible operation.

Fully reversible options (i.e similar duty in both airflow directions) are available, please contact Nuairé for details.

The unit shall have a unique mounting bracket, which shall enable the bracket to be positioned as a "first fix" component with the unit being fitted as a "second fix" component, avoiding possible mechanical damage.

The Nuairé SVT2 unit shall have inlet guards for safety purposes and also to prevent debris being sucked through the fan.

It also has a specially designed airflow deflector to direct the jet stream from the fan at the required angle sufficient to overcome the natural buoyancy effect of the smoke. (see page 2 for adjusting).

EN12101-3 compliant, refer to EC certificate of conformity, 0086-CPD-467873.

Handling

Always handle the units carefully to avoid damage and distortion. If mechanical aids are used to lift the unit, spreaders should be employed and positioned so as to prevent the slings, webbing etc. making contact with the the casing.

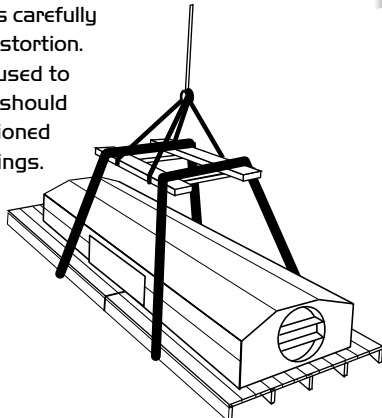

Figure 1.

Installation

Installation must be carried out by competent personnel in accordance with the appropriate authority and conforming to all statutory governing regulations.

1) Fixing the support bracket to the ceiling

The support bracket is included with the unit. Using the four slots in the top side of the bracket attach to the ceiling ensuring that it is firmly fixed and able to take the weight (100kg) of the SVT2 unit.

Figure 2.

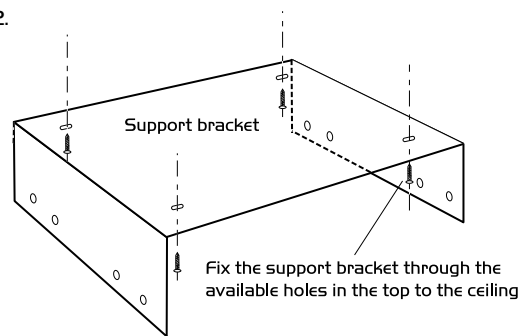

2) Fitting the SVT2 unit to the support bracket

Having fixed the support bracket the SVT2 unit can now be raised up into position between the support bracket on the ceiling and attached when required using the holes through the sides of the bracket and the unit.

Figure 3.

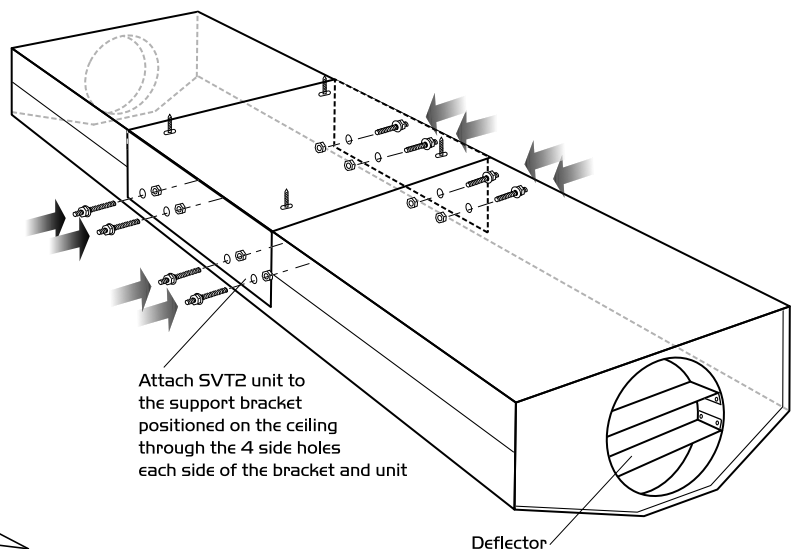

Attach SVT2 unit to the support bracket positioned on the ceiling through the 4 side holes each side of the bracket and unit

Deflector

3) Adjusting the SVT2 Deflector blades

The Deflector blades are factory set for horizontal discharge (default setting) but can be adjusted for downward deflection using the following procedure.

1. Adjust top blade (A) by removing the 2 screws at the front either side of the blade, tilt down and replace the screws.
2. Adjust bottom blade (B) by removing the 2 screws at the back either side of the blade, tilt upwards and replace the screws.

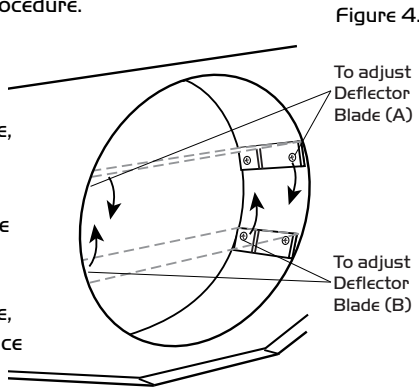
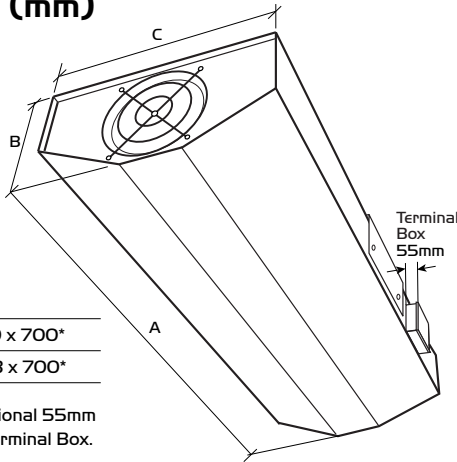

Figure 4.

Dimensions (mm)

Figure 5.



Dimensions A x B x C

SVT2-1	2300 x 320 x 700*
SVT2-2	2300 x 403 x 700*

*Please allow an additional 55mm for the width of the Terminal Box.

Electrical Information

Motors are totally enclosed and protected to IP55 (Dust and low pressure water jets). Motors comply with B55000, EN600034 and IEC34-1. Enclosures are to IP55 with class H insulation. Motors are tested in accordance with EN12101-3 2002. **N.B. Please note the requirements for maintenance of the motor. Failure to comply with the recommendations will invalidate any warranty claim.**

Wiring

Electrical supply wiring connection is to an externally mounted terminal box on the case exterior. The box is pre-wired to the motor with heat resisting cable.

NOTE: If a two speed starter is used it must have 3 contactors. Individual wiring diagrams are included with each unit.

A matched Nuair Inverter Speed Control is available. Please contact Nuair.

Two speed 3 phase TAP/PAM wound motors (D.O.L. starting both speeds)

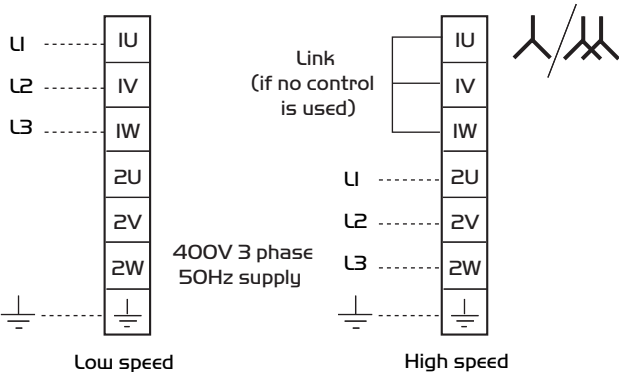

Connection details

Check that the voltage full load and starting current on the fan rating label is suitable for your supply.

Two speed motors

Two speed motors are supplied Tap or Pam single winding.

All two speed types are designed for Direct On Line starting on both speeds only unless otherwise specified.

Note: Tap wound motors require a three contactor control. Individual wiring instructions are included with each unit.

Start up procedure

Ensure that the impeller rotation follows the label arrow indicator on the casing. Should the direction be incorrect on three phase units, reverse any two of the supply leads. Care should be taken to set correct rotation as incorrect rotation may result in damage to the motor. Equipment should be run for approx. 30 minutes to ensure correct operation. If any fault occurs, the equipment should be switched off. **Do not re-start until the fault has been rectified.**

Maintenance

General

Nuair recommends all products maintained in accordance with the HVCA "Standard Maintenance Specification for Mechanical Services in Buildings" - Volume II Ventilating and Air Conditioning. For guidance only due to the different periods of operation from the time of installation and conditions of use, no rigid inspection and maintenance periods can be recommended. We suggest, therefore that the inspection and if necessary cleaning should be carried out at regular intervals of 1000 hours of operation or 3 months, whichever is the sooner. For a routine inspection, check the tightness of all nuts, keys, grub screws and endbolts etc. Remove any build up of dirt or dust with a brush.

Motors

On going maintenance - Induction motors, by their very nature require minimal maintenance. However, a regular regime of inspection is recommended to ensure minor problems do not escalate into breakdowns. Typical intervals would be 1000 hours of operation or 3 months, whichever is the sooner.

Checklist

- No visible damage i.e. impeller cracked, fan cowl bent, foot cracked etc.
- No accumulation of dust or fibres on the frame or around the fan inlet.
- No significant corrosion of the lifting lugs/eyebolts.
- No excessive vibration.
- No loose fasteners.
- Cables and earths are sound.
- Sealing of the motor and gland plate in good condition.
- Insulation resistance adequate, imperative this is checked after prolonged shutdown.

IMPORTANT

For good EMC engineering practice, any sensor cables or switched live cables should not be placed within 50mm of other cables or on the same metal cable tray as other cables.

Specific Commissioning and Servicing Requirements

Motors for Smoke Extract Fans

Exposure temperature/time: 300°C for 120 minutes.
 These motors are used to provide a SAFETY FUNCTION for people in the event of fire in public premises or in the home: they are therefore subject to strict constraints concerning their operating and maintenance.

Operating constraints

- i. Check on the nameplate that the selected motor corresponds to the maximum exposure temperature and duration.
- ii. Non ventilated motors MUST be placed in the airflow from the driven fan. Ventilated motors can be placed outside the flow.
- iii. **AFTER THE MOTOR HAS BEEN SUBJECTED TO ONE EMERGENCY DUTY OPERATION, IT MUST BE REPLACED.**
- iv. With variable speed control. Ensure that the maximum speed never exceeds the speed of the motor supplied by the mains and that the delivered power corresponds to the previous definitions.

These qualifications ensure the qualification of the driven fan by the manufacturer.

Maintenance Constraints

Regular service visits must be performed on the installation at least every 6 months, incorporating the following checks:

i. Checking the insulation resistance (R>100MΩ, 500V DC)

- a) If the drain holes are blocked, open them to eliminate any accumulated condensation.
- b) If R<100MΩ, dry the stator in an oven and check the insulation resistance. If the fault persists, replace the stator.
- c) The stator must be replaced 5 years after installation or after 20,000 hours of operation.

ii. Cooling check

- a) Ensure there is no dust or grease in the entire ventilation circuit (housing fins, motor cover/fan if fitted driven fan).
- b) Ensure the motor runs normally when switched on for a few minutes.

iii. Bearing check (C3 or C4 play)

Run the motor during each maintenance visit. When the motor is cold, a high level of noise is caused by the texture of the grease. This does not indicate a bearing fault.

S2 duty only:

The bearings must be replaced by an identical type every 5 years. Ensure the motor runs normally when switched on for a few minutes.

S1 duty and Emergency in S2 duty:

- a) Permanently greased bearings.

300°C range; replace on 2 pole motors after 10,000 hours of operation and on motors with 4 poles or more after 20,000hours.

- b) Re-greaseable bearings

The information on the motor nameplates must be strictly respected

(grease quantity, grease quality and re-greasing frequency).

The bearings must be replaced after 20,000 hours of operation.

Replacement of parts

When ordering spares it is important to state the unit serial number to ensure that the correct spares will be supplied.

Notes - Fixing bolts, nuts, studs, screws, spacers or washers are not included with these parts and if required, should be clearly specified on the order in addition to the part description number.

Warranty

The three year warranty starts from the day of delivery and includes parts and labour for the first year. The labour element is subject to full, free and safe access to the equipment as recommended by the CDM regulations.

The remaining two years covers replacement parts only.

Note: Installation and maintenance of the equipment must be undertaken as directed in the instructions provided with the unit.

Enquiries

Please contact Nuair Limited for information on any aspects of the motor performance that may need clarification. Contact must be made prior to any remedial action being taken under the warranty.

Please quote the motor serial number in all such cases with detailed description of the problem.

Service Enquiries

Our service department will be happy to provide any assistance or further information required. If you have any comments or queries on any of our products or services please write to the Product Information Manager at the main address on page one of this document.

Customer Services Department

Tel: 02920 858 585



Fax: 02920 858 586

DECLARATION OF INCORPORATION AND INFORMATION FOR SAFE INSTALLATION, OPERATION AND MAINTENANCE

We declare that the machinery named below is intended to be assembled with other components to constitute a system of machinery. The machinery shall not be put into service until the system has been declared to be in conformity with the provisions of the EC Machinery Directive.

Designation of machinery: Axus SVT2 Impulse Fan
Machinery Types: High Temperature Axial Fans
Relevant EC Council Directives: 98/37/EC as amended by 98/79/EC (Machinery Directive)
Applied Harmonised Standards: BS EN ISO 12100-1, BS EN ISO 12100-2, EN294, EN60204-1, BS EN ISO 9001
Applied National Standards: BS848 Parts One, Two and Five

Signature of manufacture representatives:

Name:	Position:	Date:
1) C. Biggs 	Technical Director	20.07.07
2) W. Glover 	Manufacturing Director	20.07.07

INFORMATION FOR SAFE INSTALLATION, OPERATION AND MAINTENANCE OF NUAIRE VENTILATION EQUIPMENT

To comply with EC Council Directives 98/37/EC Machinery Directive and 2004/108/EC (EMC).

To be read in conjunction with the relevant Product Documentation (see 2.1)

1.0 GENERAL

- 1.1 The equipment referred to in this Declaration of Incorporation is supplied by Nuairé to be assembled into a ventilation system which may or may not include additional components.
 The entire system must be considered for safety purposes and it is the responsibility of the installer to ensure that all of the equipment is installed in compliance with the manufacturers recommendations and with due regard to current legislation and codes of practice.

2.0 INFORMATION SUPPLIED WITH THE EQUIPMENT

- 2.1 Each item of equipment is supplied with a set of documentation which provides the information required for the safe installation and maintenance of the equipment. This may be in the form of a Data sheet and/or Installation and Maintenance instruction.
 2.2 Each unit has a rating plate attached to its outer casing. The rating plate provides essential data relating to the equipment such as serial number, unit code and electrical data. Any further data that may be required will be found in the documentation. If any item is unclear or more information is required, contact Nuairé.
 2.3 Where warning labels or notices are attached to the unit the instructions given must be adhered to.

3.0 TRANSPORTATION, HANDLING AND STORAGE

- 3.1 Care must be taken at all times to prevent damage to the equipment. Note that shock to the unit may result in the balance of the impeller being affected.
 3.2 When handling the equipment, care should be taken with corners and edges and that the weight distribution within the unit is considered. Lifting gear such as slings or ropes must be arranged so as not to bear on the casing.
 3.3 Equipment stored on site prior to installation should be protected from the weather and steps taken to prevent ingress of contaminants.

4.0 OPERATIONAL LIMITS

- 4.1 It is important that the specified operational limits for the equipment are adhered to e.g. operational air temperature, air borne contaminants and unit orientation.
 4.2 Where installation accessories are supplied with the specified equipment eg. wall mounting brackets. They are to be used to support the equipment only. Other system components must have separate provision for support.
 4.3 Flanges and connection spigots are provided for the purpose of joining to duct work systems. They must not be used to support the ductwork.
 4.4 In the event of RF interference the fan may increase in speed or make high pitched noises. This is normal and will have no adverse effect on the fan. The speed and noise will return to normal once the interference has subsided.

5.0 INSTALLATION REQUIREMENTS

In addition to the particular requirements given for the individual product, the following general requirements should be noted.

- 5.1 Where access to any part of equipment which moves, or can become electrically live are not prevented by the equipment panels or by fixed installation detail (eg ducting), then guarding to the appropriate standard must be fitted.
 5.2 The electrical installation of the equipment must comply with the requirements of the relevant local electrical safety regulations.
 5.3 For EMC all control and sensor cables should not be placed within 50mm or on the same metal cable tray as 230V switched live, lighting or power cables and any cables not intended for use with this product.

6.0 COMMISSIONING REQUIREMENTS

- 6.1 General pre-commissioning checks relevant to safe operation consist of the following:
 Ensure that no foreign bodies are present within the fan or casing.
 Check electrical safety. e.g. Insulation and earthing.
 Check guarding of system.
 Check operation of Isolators/Controls.
 Check fastenings for security.
 6.2 Other commissioning requirements are given in the relevant product documentation.

7.0 OPERATIONAL REQUIREMENTS

- 7.1 Equipment access panels must be in place at all times during operation of the unit, and must be secured with the original fastenings.
 7.2 If failure of the equipment occurs or is suspected then it should be taken out of service until a competent person can effect repair or examination. (Note that certain ranges of equipment are designed to detect and compensate for fan failure).

8.0 MAINTENANCE REQUIREMENTS

- 8.1 Specific maintenance requirements are given in the relevant product documentation.
 8.2 It is important that the correct tools are used for the various tasks required.
 8.3 If the access panels are to be removed for any reason the electrical supply to the unit must be isolated.
 8.4 A minimum period of two minutes should be allowed after electrical disconnection before access panels are removed. This will allow the impeller to come to rest.
NB: Care should still be taken however since airflow generated at some other point in the system can cause the impeller to "windmill" even when power is not present.
 8.5 Care should be taken when removing and storing access panels in windy conditions.