



Technical Support Dept. T. 02920 858585 F. 02920 858586

# Drimaster - Hints & Tips

## 1.0 On installation

Follow the installation and maintenance document 671104, paying particular attention to;

- I.1. Loft ventilation; whilst the system is fully automatic its obviously drawing air from the loft and this air has to be replaced so.
  - I.1.1. A loft sealed from the outside will have a detrimental effect on the DRIMASTER'S efficiency.
  - I.1.2. A loft floor or room ceilings below which contain unsealed holes or recessed lighting such as spotlights can allow the air to be drawn from the dwelling and hence re circulate it. Also ensure the loft hatch is sealed airtight.
- I.2. The position of the unit's supply air diffuser in the landing ceiling should be carefully considered.
  - I.2.1. Be aware of the possibility of asbestos in the ceilings and the regulations requiring a test before you cut the hole.
  - I.2.2. Site the diffuser so that the airflow from it will be of least annoyance to the householder.
  - I.2.3. Site the diffuser so that nothing i.e. smoke alarms are within 1 Metre of it, and that the air doesn't discharge directly to a wall.

4 Diffuser frame fixing screws  
Airflow from two sides

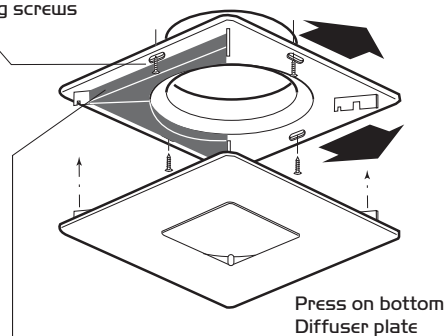

2 Foam strips (supplied) fit on any of the diffuser sides

- I.2.4. Normally the diffuser discharges air from all four sides but is supplied with foam strips to blank any side with the potential for nuisance. (see fig. above).

I.3. The position of the unit.

- I.3.1. Units can be installed suspended from the roof joist...

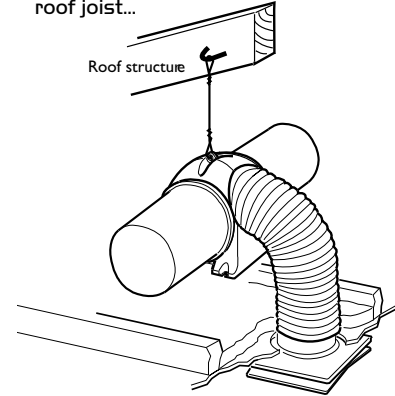

...or mounted on the ceiling joist.

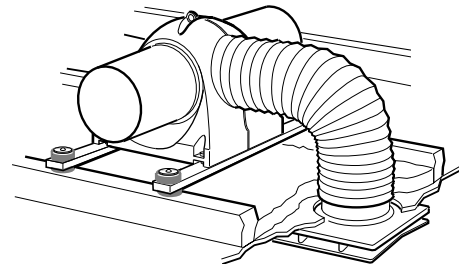

When installing on ceiling joist use the optional anti vibration mounting kit part number 771393 to prevent noise transfer.

- I.3.2. Although the unit is exceptionally quiet try to keep it away from 'over bed' positions.
- I.3.3. The unit is supplied with a pre wired mains to low voltage power supply and a mains fused spur box, as the unit is to be on at all times for effective ventilation ensure the power supply cannot be manually disrupted.
- I.4. Setting to work.
  - I.4.1. Set the DRIMASTER speed appropriate to the size and type of property, see I&M paragraphs 9 & 10.

## 2.0 On maintenance

None required in the first five years.

## 3.0 On spares

The only replaceable items on a DRIMASTER are the filters and they only after five years, should a control or motor defect arise then complete unit replacement is recommended.

0.01



Nuaire Limited Western Industrial Estate Caerphilly United Kingdom CF83 1NA  
Telephone: 029 2085 8200 Facsimile: 029 2088 7033  
Email: info@nuaire.co.uk www.nuaire.co.uk



# Drimaster - Hints & Tips

## 4.0 Trouble-shooting

Complaints are generally that the unit is 'not working' so it will be first necessary to distinguish between an electrical/mechanical malfunction or

whether the unit operates but simply fails to deal with the condensation or mould growth condition.

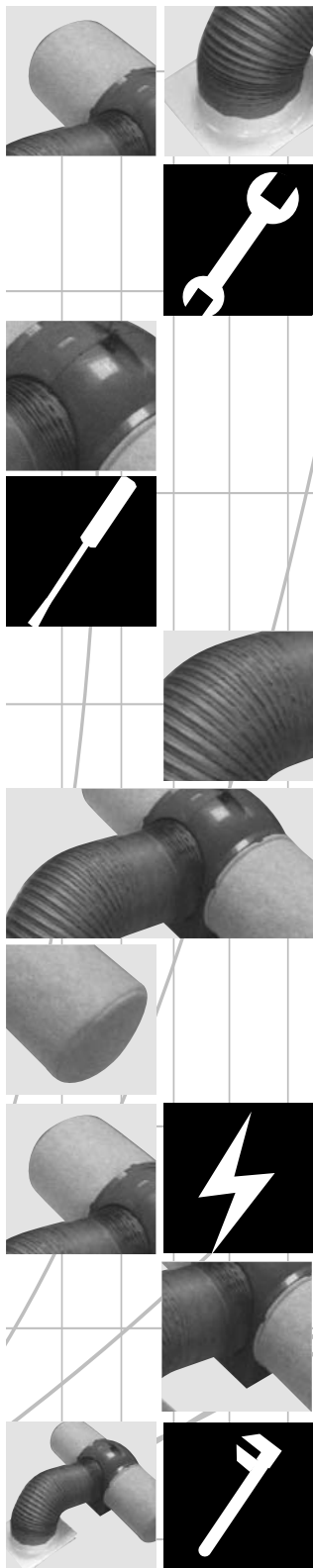

Complaint	Cause and correct	Complaint	Cause and correct
Noise.	<p>Fan speed too high, adjust same.</p> <p>Fan impeller rumble due to shaft centre fix screw loose – tension same.</p> <p>Vibrational noise through ceiling – suspend unit or fit AV kit where unit is on joists.</p>	Draughts/cold.	<p>The movement of air is essential to the process of combating condensation and mould growth and the 'freshness' that results is normal and a sure sign the system is working.</p> <p>Check position of diffuser.</p> <p>Check fan speed and if necessary reduce same.</p>
Not clearing condensation and/or mould growth.	<p>Ensure ALL gaps and holes in ALL ceilings are closed.</p> <p>Ensure air is free to pass throughout property, under doors etc.</p> <p>Increase fan speed.</p> <p>Review tenant lifestyle i.e. drying clothes on radiators.</p> <p>Additional and locally positioned enhancement fans may be required.</p>	Musty smells carried by the air from the diffuser.	<p>Usually due to poor loft ventilation, to fix may require additional tile or soffet vents etc.</p>
Not working would usually suggest that it has at sometime functioned correctly.	<p>Ensure unit hasn't been switched off or that the local fuse hasn't blown.</p> <p>If power at unit (LEDs lit) and unit not running may have shut down on high loft temperature – this is normal, see temperature control options.</p> <p>All three LEDs flashing and fan not running signifies a motor failure – replace the unit.</p> <p>If electricity present, power off, wait and power on again – this may restart the unit.</p>	Black marks appearing on the ceiling in the vicinity of the diffuser.	<p>Not necessarily as a result of a dirty filter but its still worth checking, filters have a five year life.</p> <p>The air from the diffuser tends to swirl across the ceiling and walls and in so doing 'collects' normal house dust particles.. This is not unusual and regular cleaning of the affected area is required to keep this under control.</p>

0.01

