

# squrboXbox

Installation and Maintenance

## squrboXbox. Packaged supply and extract fans with heat recovery

This unit houses two fan units with associated air filters, a plate heat recovery section and an optional supplementary heater (electric or LPHW).

Also fitted are Ecosmart controls that allow individual or linked control of the fans/heater.

### I.0 Coding

The coding structure is: (e.g. S5-XB-RE)

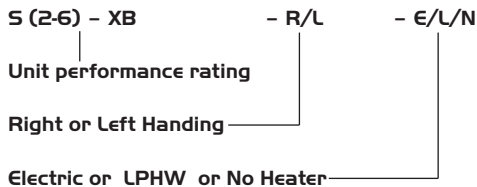

For systems which include supply fans with heating coils, other than where the BMS has control, the appropriate user control is required.

### I.1 Handling

Always handle the units carefully to avoid damage and distortion. Care must be taken to ensure that any slings used for hoisting or lifting equipment employed does not damage the casing or the control module components.

### I.2 Unit Installation

The fan must be fitted indoors, on a secure surface, away from sources of water spray or steam generation. The fan is installed by using drop-rods and bearers (by others figure I). Consideration must be given when supporting the unit that access is still available for maintenance purposes and removal of filters.

**Note that the unit is only suitable for horizontal mounting.**

Figure 1.

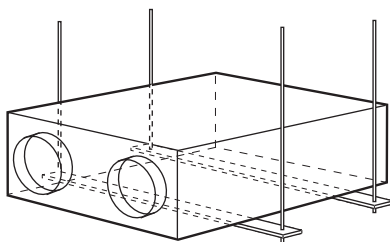

#### IMPORTANT

Isolation - Before commencing work make sure that the unit, switched live and Nuaire control are electrically isolated from the mains supply.

### I.4 Unit Installation

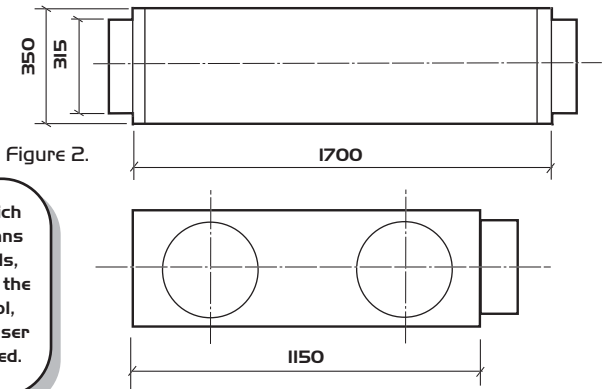
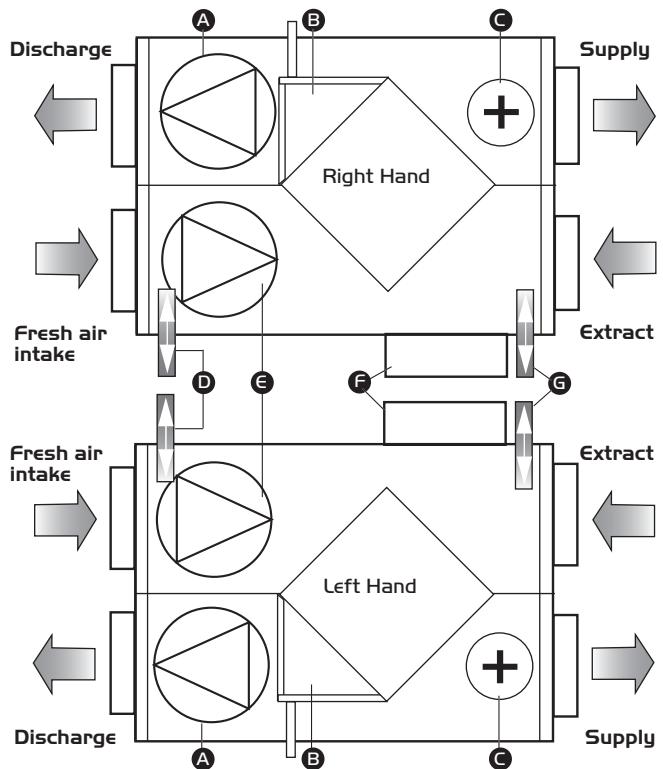

Figure 2.

Figure 3. Plan view (from above).



### I.5 Access for Maintenance -

#### Component location

- A Extract Fan
- B Condensate tray\*\*
- C Heater
- D Supply Filter\*
- E Supply Fan and Heat Exchanger
- F Controls
- G Extract Filter \*

\* regular maintenance required  
 \*\* regular maintenance may be required (dependant on installed conditions).

Other components are unlikely to need attention on a regular basis. Access space around the unit is recommended as being a minimum of 600mm. (See Approved Document FI - 2006 sections 2.6, 2.7).

### 1.6 Installing the Water Circuit

It is recommended that a strainer and isolating valves are fitted (by others) for ease of maintenance. (See figure 4).

Figure 4.

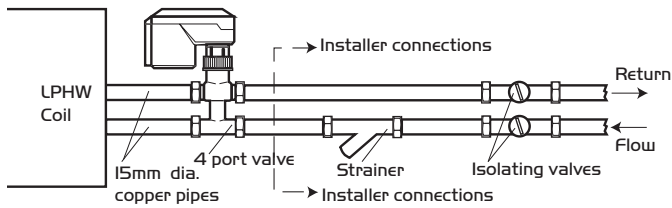

### 2.0 Wiring

The electrical wiring must be carried out by competent persons, in accordance with good industry practice and should conform to all governing and statutory bodies i.e. IEE, CIBSE, COHSE etc.

#### Connections

##### a) Control Connections

**Net** - the 4 IDC plug-in connectors are provided for the connection of compatible sensors, manual controls and for linking the fans together under a common control. If more than 4 connections are required, the junction box (product code ES-JB) should be used (see data cable installation).

**Switch Live (SL) terminal** - A signal of 100-230V a.c. will activate the fan.

**Note that a signal from an isolating transformer will produce an unpredictable result and is not recommended.**

##### b) Damper Connections

- OP** - 230V 50Hz IA max supply to open the damper
- CL** - 230V 50Hz IA max supply to close the damper
- N** - Neutral supply to damper
- RET** - 230V ac return signal from the damper limit switch indicates the damper has reached its operating position. If the return signal is not present, the fan will wait for 1 minute before starting.

**Note: If a damper is not fitted, connect a link wire from OP to RET. This will cancel the delay.**

#### Wiring for fans without Electric Heater

Figure 5.

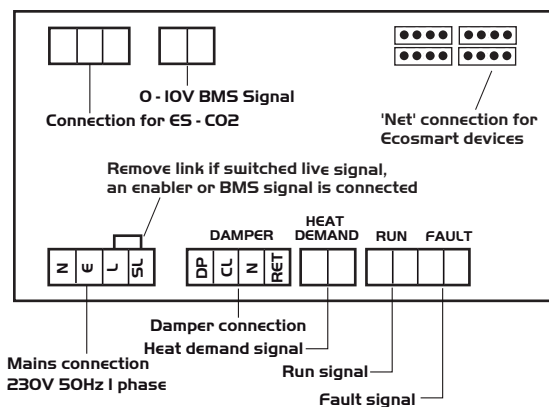

##### c) Volt Free Relay Contacts

Note that the volt free contacts are not fused. If these are used to power any external equipment, the installer must provide adequate fusing or other protections.

These contacts are rated at 5A resistive, 0.5A inductive.

**Run connections** - These contacts are closed when the fan is running.

**Fault connections** - No fault = the contacts are closed. Fault = the contacts are opened.

**Heat demand** - contacts closed when heating is selected.

##### d) Data Cable Installation

A 4-core SELV data cable is used to connect devices. Do not run data cable in the same conduit as the mains cables and ensure there is a 50mm separation between the data cable and other cables. The maximum cable run between any two devices is 300m when it is installed in accordance with the instructions.

**Please note that the total data cable length used in any system must be less than 1000m. Keep the number of cable joints to a minimum to ensure the best data transmission efficiency between devices.**

##### e) Maximum Number of Devices

The maximum number of devices (including fans) that can be connected together via the cable is 32, irrespective of their functions.

##### f) Other Low Voltage Cables

Follow the basic principle (as d). Keep the cable run as short as possible, less than 50 metres.

### Electrical Details

Fans without Electric Heater		Fans with Electric Heater		A (total for unit)
Unit Code	f/c (amps)	Unit Code	f/c (amps)	
S2-XB*N/L	1.7	S2-XB*E	22	
S3-XB*N/L	1.9	S3-XB*E	22	
S4-XB*N/L	2.8	S4-XB*E	23	
S5-XB*N/L	3.3	S5-XB*E	24	
S6-XB*N/L	6.0	S6-XB*E	33	

#### Wiring for fans with Electric Heater

Figure 6.

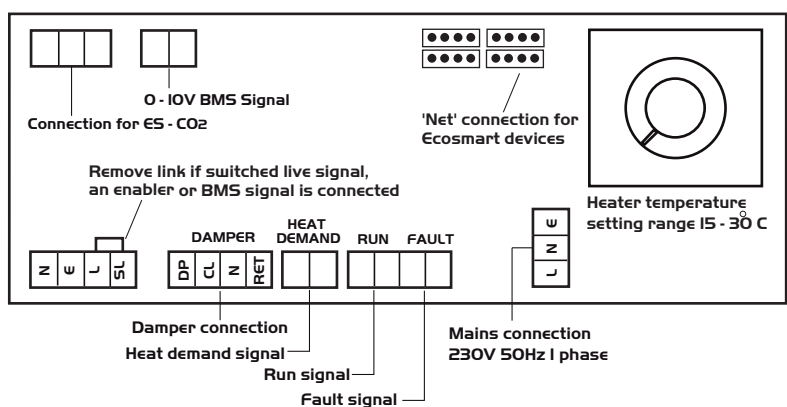

### 3.0 Setting to Work

#### Using the Test Button

The test button allows the individual blowers within the unit to be checked for its operation. If the fan is running already, press the button once to stop the fan, press again to switch on the fan.

**Note that the fan will return to normal operation after 30 seconds.**

#### IMPORTANT

Note: this unit contains two fan units and two controls. Generally, it is recommended that the two fans are operated together (this requires a data link between the controls), but the fans are capable of independent operation if required.

#### LED Indication

- PWR** GREEN: Power on & OK, Standby LED on when fan is not running.
- Fan 1** GREEN: Fan 1 is running, RED: Fan 1 faulty.
- Fan 2** GREEN: Fan 2 is running, RED: Fan 2 faulty.
- Heating\*** GREEN: Heating selected RED: Heating faulty.
- Cooling\*** Not applicable. See note.
- Fault** LED on when a fault is present on unit.
- Frost\*** Not applicable. See note.
- Tx** LED on when the controller is transmitting data.
- Rx** LED on when the controller is receiving data.

\* Note that the control panel is common to all the Ecosmart products and will have indicators for functions that are not available in this particular fan. However these indicators will not be illuminated.

Setting to Work cont.

## BMS Input Signals

The system's response to a 0-10V dc BMS signal is given in the following table.

**Note the BMS signal will override any sensors and user control connected in the system. The voltage tolerance is +/- 125mV and is measured at the fans terminal.**

	Ventilation mode	Cooling mode*	Heating mode*
Local control	0.00	-	-
OFF / trickle	0.25	-	-
Speed 1	0.50	0.75	1.00
Speed 2	1.50	1.75	2.00
Speed 3	2.50	2.75	3.00
Speed 4	3.50	3.75	4.00
Speed 5	4.50	4.75	5.00
Speed 6	5.50	5.75	6.00
Speed 7	6.50	6.75	7.00
Speed 8	7.50	7.75	8.00
Speed 9	8.50	8.75	9.00
Speed 10	9.50	9.75	10.00

\* Only available on relevant unit

## Settings

### Setting the maximum air flow

ii) Ensure the power supply is switched off and that a link wire is connected from the supply L to the SL terminal. Unplug all items connected to the 'Net' connectors.

ii) Switch on the power supply.

iii) Wait for the fan to complete its self-test operation.

Measure the airflow using standard commissioning instruments at a suitable point in the ductwork. If adjustment is required, rotate the pot marked 'MAX' to obtain the desired airflow.

### Setting the minimum trickle airflow (nominal 40%)

i) Repeat the same procedure as for maximum airflow above but without the link wire between supply L and SL terminal. Ensure the trickle switch is in the 'ON' position. Adjustment must be made on the pot marked 'Min'.

ii) Note that the minimum setting (nominally 40%) must be below the maximum setting, otherwise minimum setting will be automatically set to be the same as the maximum.

### Setting the overrun time

A switched live of 100-230V at terminal SL will activate the fan. When the switched live signal is removed the fan will overrun for period set by the dial 'SL run on' - adjust the desired overrun time by rotating clockwise.

### Setting the trickle ventilation facility

Slide the 'trickle' switch O = Off, I = On. With 'trickle' on and power to unit the fan will run at minimum speed until the switch live signal activates it to boost.

### Setting the 'air off' temperature

The adjustment knob is located in the control pack and must be set to the desired 'air off' temperature.

Figure 7.

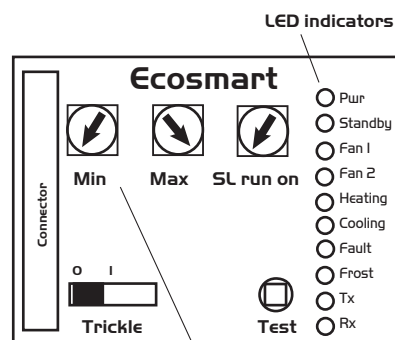

MIN = Minimum speed adjustment  
 MAX = Maximum speed adjustment  
 SL = Switched Live Run-On  
 Run on = Switched Live Run-On  
 Timer adjustment  
 TRICKLE = Selects trickle running:  
 O = off, I = selected  
 TEST = Test button

## 4.0 Maintenance

The first maintenance should be carried out three months after commissioning and thereafter at twelve monthly intervals. These intervals may need to be shortened if the unit is operating in adverse environmental conditions, or in heavily polluted air.

### Lubrication

Motors are fitted with sealed for life bearings and do not require any lubrication.

### General Cleaning and Inspection

Clean and inspect the exterior of the fan unit and associated controls etc. Remove the access panel from the fan unit, inspect and, if necessary, clean the fan and motor assemblies, heat exchanger and condensate tray, and the interior of the case. If the unit is heavily soiled it may be more convenient to remove the various assemblies. Check all parts for security and that the impeller rotates freely, taking care not to disturb the balance. Ensure all control components are secure and clean, refit all access doors. Do not use solvents or corrosive agents for cleaning.

### Filter care/replacement

The filters inside the Scurbo X-BOX unit will require changing on a regular basis. The frequency will depend on the site conditions.

**Note: It is important to allow sufficient time for the heater battery (where fitted) to cool down before beginning work.**

**Remove the access panel and withdraw, remove and replace the filters.**

## Cleaning Control Box and Sensors (if fitted)

Remove covers and carefully clean out interiors as necessary. Check for damage and security of components. Refit covers.

### Replacement of Parts

Should any component need replacing Nuair keep extensive stocks for quick delivery. Ensure that the unit is electrically isolated, before carrying out any work.

When ordering spare parts, please quote the serial number of the unit and the ARC number of the purchase if possible.

**(This information will be available on the fan label).**

### 3 Year Warranty

The 3 year warranty starts from the day of delivery and includes parts and labour for the first year. The remaining 2 years covers replacement parts only. This warranty is conditional on planned maintenance being undertaken.

### Service Enquiries

Nuair can assist you in all aspects of service. Our service department will be happy to provide any assistance required, initially by telephone and if necessary arrange for an engineer to call.

**Telephone 029 2085 8585**  
**Fax 029 2085 8586**



Technical or commercial considerations may, from time to time, make it necessary to alter the design, performance and dimensions of equipment and the right is reserved to make such changes without prior notice.

## DECLARATION OF INCORPORATION AND INFORMATION FOR SAFE INSTALLATION, OPERATION AND MAINTENANCE

We declare that the machinery named below is intended to be assembled with other components to constitute a system of machinery. The machinery shall not be put into service until the system has been declared to be in conformity with the provisions of the EC Machinery Directive.

Designation of machinery: **SQRBOXBOX**  
 Machinery Types: **SQRBOXBOX**  
 Relevant EC Council Directives: **98/37/EC as amended by 98/79/EC (Machinery Directive)**  
 Applied Harmonised Standards: **BS EN ISO 12100-1, BS EN ISO 12100-2, EN294, EN60204-1, BS EN ISO 9001**  
 Applied National Standards: **BS848 Parts One, Two and Five**

### Signature of manufacture representatives:



Name:	Position:	Date:
1) C. Biggs 	Technical Director	20. 07. 07
2) W. Glover 	Manufacturing Director	20. 07. 07

## CE DECLARATION OF CONFORMITY

We declare that the machine named below conforms to the requirements of EC Council Directives relating to Electromagnetic Compatibility and Safety of Electrical Equipment.

Designation of machinery: **SQRBOXBOX**  
 Machinery Types: **SQRBOXBOX**  
 Relevant EC Council Directives: **2004/108/EC (EMC)  
 2006/95/EC (Low Voltage Directive)**  
 Applied Harmonised Standards: **EN55014-1, EN55014-2, EN60335-2-80**  
 Basis of Self Attestation: **Quality Assurance to BS EN ISO 9001  
 BSI Registered Firm  
 Certificate No. FM 149**

### Signature of manufacture representatives:

Name:	Position:	Date:
1) C. Biggs 	Technical Director	20. 07. 07
2) W. Glover 	Manufacturing Director	20. 07. 07

## INFORMATION FOR SAFE INSTALLATION, OPERATION AND MAINTENANCE OF NUAIRE VENTILATION EQUIPMENT

To comply with EC Council Directives 98/37/EC Machinery Directive and 2004/108/EC (EMC).

To be read in conjunction with the relevant Product Documentation (see 2.1)

### 1.0 GENERAL

1.1 The equipment referred to in this Declaration of Incorporation is supplied by Nuairé to be assembled into a ventilation system which may or may not include additional components.  
 The entire system must be considered for safety purposes and it is the responsibility of the installer to ensure that all of the equipment is installed in compliance with the manufacturers recommendations and with due regard to current legislation and codes of practice.

### 2.0 INFORMATION SUPPLIED WITH THE EQUIPMENT

- 2.1 Each item of equipment is supplied with a set of documentation which provides the information required for the safe installation and maintenance of the equipment. This may be in the form of a Data sheet and/or Installation and Maintenance instruction.
- 2.2 Each unit has a rating plate attached to its outer casing. The rating plate provides essential data relating to the equipment such as serial number, unit code and electrical data. Any further data that may be required will be found in the documentation. If any item is unclear or more information is required, contact Nuairé.
- 2.3 Where warning labels or notices are attached to the unit the instructions given must be adhered to.

### 3.0 TRANSPORTATION, HANDLING AND STORAGE

- 3.1 Care must be taken at all times to prevent damage to the equipment. Note that shock to the unit may result in the balance of the impeller being affected.
- 3.2 When handling the equipment, care should be taken with corners and edges and that the weight distribution within the unit is considered. Lifting gear such as slings or ropes must be arranged so as not to bear on the casing.
- 3.3 Equipment stored on site prior to installation should be protected from the weather and steps taken to prevent ingress of contaminants.

### 4.0 OPERATIONAL LIMITS

- 4.1 It is important that the specified operational limits for the equipment are adhered to e.g. operational air temperature, air borne contaminants and unit orientation.
- 4.2 Where installation accessories are supplied with the specified equipment eg. wall mounting brackets. They are to be used to support the equipment only. Other system components must have separate provision for support.
- 4.3 Flanges and connection spigots are provided for the purpose of joining to ductwork systems. They must not be used to support the ductwork.

### 5.0 INSTALLATION REQUIREMENTS

In addition to the particular requirements given for the individual product, the following general requirements should be noted.

- 5.1 Where access to any part of equipment which moves, or can become electrically live are not prevented by the equipment panels or by fixed installation detail (eg ducting), then guarding to the appropriate standard must be fitted.
- 5.2 The electrical installation of the equipment must comply with the requirements of the relevant local electrical safety regulations.
- 5.3 For EMC all control and sensor cables should not be placed within 50mm or on the same metal cable tray as 230V switched live, lighting or power cables and any cables not intended for use with this product.

### 6.0 COMMISSIONING REQUIREMENTS

- 6.1 General pre-commissioning checks relevant to safe operation consist of the following:  
 Ensure that no foreign bodies are present within the fan or casing.  
 Check electrical safety. e.g. Insulation and earthing.  
 Check guarding of system.  
 Check operation of Isolators/Controls.  
 Check fastenings for security.
- 6.2 Other commissioning requirements are given in the relevant product documentation.

### 7.0 OPERATIONAL REQUIREMENTS

- 7.1 Equipment access panels must be in place at all times during operation of the unit, and must be secured with the original fastenings.
- 7.2 If failure of the equipment occurs or is suspected then it should be taken out of service until a competent person can effect repair or examination. (Note that certain ranges of equipment are designed to detect and compensate for fan failure).

### 8.0 MAINTENANCE REQUIREMENTS

- 8.1 Specific maintenance requirements are given in the relevant product documentation.
- 8.2 It is important that the correct tools are used for the various tasks required.
- 8.3 If the access panels are to be removed for any reason the electrical supply to the unit must be isolated.
- 8.4 A minimum period of two minutes should be allowed after electrical disconnection before access panels are removed. This will allow the impeller to come to rest.  
**NB: Care should still be taken however since airflow generated at some other point in the system can cause the impeller to "windmill" even when power is not present.**
- 8.5 Care should be taken when removing and storing access panels in windy conditions.