



ecosun[®]

Application and Installation Guide (excluding Solar Air Collectors)





Application and Installation Guide

for **ecosun**[®] system
(excluding Solar Air Collectors)



Nuaire Limited Western Industrial Estate Caerphilly United Kingdom CF83 INA
Telephone: 029 2085 8441 Facsimile: 029 2085 8442
Email: info@sunwarm.com www.sunwarm.com
Email: info@nuaire.co.uk www.nuaire.co.uk

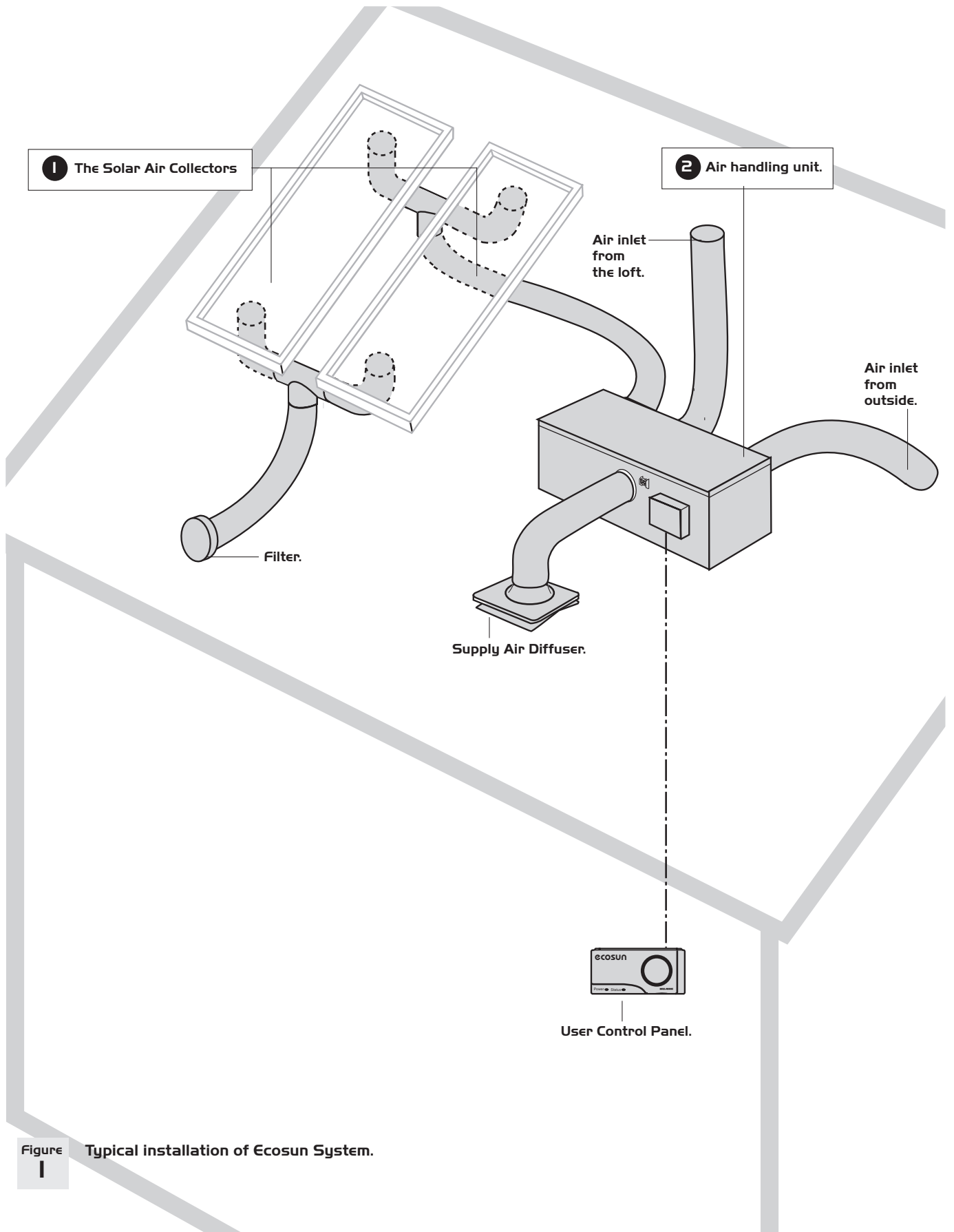

Figure 1 Typical installation of Ecosun System.

I.1 Important Notes to Designers and Installers

The successful operation of the unit depends entirely upon installation and ongoing maintenance being carried out strictly in accordance with these instructions.

Please read this guide in its entirety before installation and then repeat the exercise step by step to ensure satisfactory completion.

Suitably qualified persons may achieve installation of the unit, however the provision of the electrical supply and the connection of the unit to the mains supply should only be carried out by a qualified electrician.

The unit can be installed in a home with a “cold roof” or “warm roof”. These instructions are limited to installation in a home with a “cold roof”. “Warm roofs” vary considerably and advice should be sought from Nuaire on an individual basis.

I.2 General Description

The unit is a unique Low Energy Positive Input Ventilation (LEPIV) unit. Unlike conventional LEPIV units which only draw in external air via the loft in a “cold roof”, the unit is capable of drawing in external air from different roof locations via three air inlet spigots each fitted with their own low energy open/close damper. (See figure 1). The unit's airflow and the opening/closing of each air inlet damper is controlled via an integral intelligent control system that measures, and appropriately responds to, temperatures at the various air inlet locations, the home itself, the “target temperature” selected by the occupants on the user control panel provided and the delivered air temperature into the home.

I.3 Loft inspection

Check to ensure that the loft has adequate ventilation. Look for ridge vents, tile vents, eaves vents and continuous air gaps etc. making sure none are blocked. In older properties these vents may not be provided. However, there should be enough ‘leakage’ to accommodate the requirements of the unit. A useful way of checking such lofts is to close the hatch, switch off the lights and look for any daylight penetration. If you can see daylight it is reasonable to assume that the loft has sufficient ventilation.

There may be occasions where a loft is so well sealed that additional ventilation may have to be provided by the owner/occupier or the unit installer.

This will not only assist the operation of the unit, but will help prevent possible expensive structural damage caused by inadequate air movement in the loft itself.

It should be noted that there cannot be too much ventilation into the loft.

Additional checks should be carried out as follows:

- Ensure that all water tanks are covered and sealed.
- Check that all water pipes are lagged.
- Ensure that any extract fans are discharging to outside and not into the loft.
- Check that the loft hatch is tightly sealed.
- Ensure all holes in the ceilings are sealed i.e. ceiling light fittings etc.
- A visual inspection of flues or chimneys for leakage in the loft should be carried out by the installer. If leakage points are found, or if there is any doubt regarding the same the installer should advise the house owner/provider and seek instruction from them before continuing with installation.

Please note:

I. Note: This manual covers installation of the Air Handling Unit and associated components only. For Collector installation instructions refer to manual number 671274, which can be downloaded from the Sunwarm Website.

All other installation materials (see table on page 6) must be purchased separately or provided by the installer.

2. The 4 temperature sensors (one for each of the air inlet locations and one for the home itself) and associated sensor cables (15m long) are supplied with the unit.

3. The Net cable (10m long) connecting the unit to the user control is also supplied.

2.0 Installation of the Diffuser

2.1 Positioning the Diffuser

The diffuser has a unique air throw pattern and it must be located correctly in the central hallway in single storey properties or in the ceiling of the top floor landing on 2 or more storey dwellings.

As can be seen (Figure 2) the diffuser discharges air from all four sides along the underside of the ceiling. The majority of the air is discharged through the two longer open sides and it is vital that the diffuser is positioned to ensure these two sides discharge the air down the longest lengths of the hallway or landing. Obstructions within 1m of the diffuser will cause a poor airflow pattern and unacceptable draughts. Up to two sides of the diffuser may be closed off using the foam strips supplied.

Figure 2

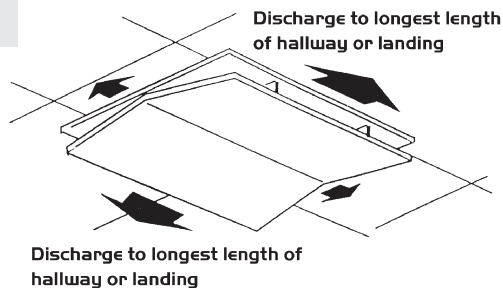

Note: Smoke Detectors

It is important that any open side of the diffuser is not positioned within 1.5m of a smoke detector.

If the diffuser cannot be repositioned, up to two sides of the diffuser may be closed off using the foam strips supplied so that the open sides face a minimum 1.5m unobstructed path away from the detector.

As an alternative to the aforementioned, a smoke detector maybe fitted directly onto the underside of the diffuser.

2.2 Fitting the Diffuser

Cut a circular hole 225mm diameter in the ceiling between two joists. Position the diffuser frame and secure to the underside of the ceiling with the 1 1/2" x 8 csk screws and plugs provided.

Attach the diffuser plate to the frame using the two 1" x 8 csk screws provided. (See figure 3).

Figure 3

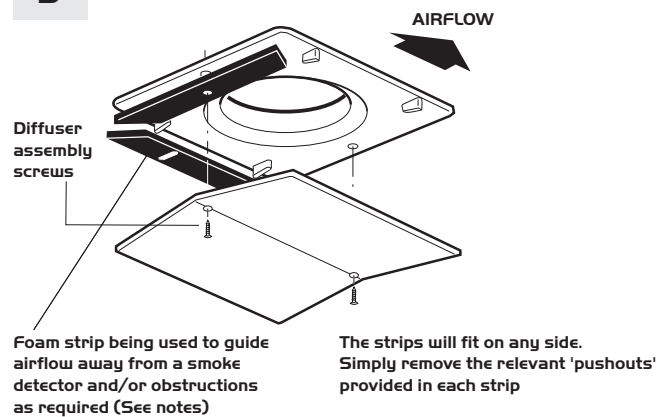

Where there is a requirement for maintaining fire rating of the ceiling then the following alternative method of installing the diffuser using a 200mm dia. spigot available from Nuaire and a "Fireblock" is recommended. (See figure 4).

Designed to provide 1 hour of fire resistance in accordance with BS476 Part 20 (1987) and ISO 834, this circular "Fireblock" is available to fit snugly inside our standard 200mm dia. spigot. (Part No. O11740).

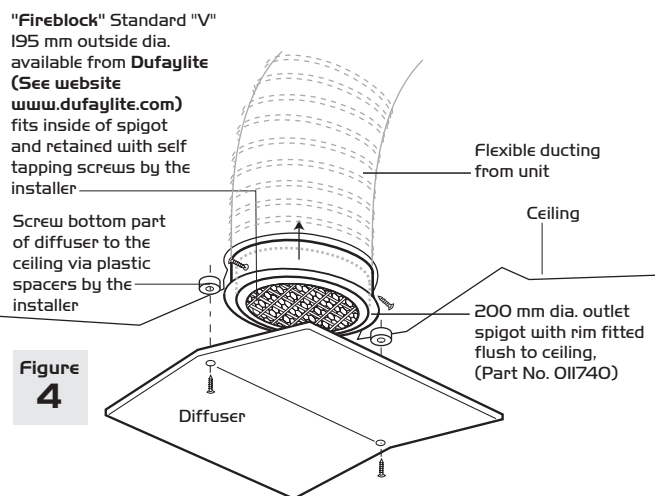

Foam strips should also be used as required when this method of installing the diffuser is used.

3.0 Installation of the Air Handling Unit and Associated Components

3.1 Fitting the Air Handling Unit

The air handling unit is supplied with eyelets for suspension between the roof trusses. It is the responsibility of the installer to supply and fit suitable hanging brackets/wires (See Figure 5).

Install the unit in a position that ensures that all ducting takes the least complex route.

The air handling unit should be positioned to ease maintenance. Please note that a clear distance of 500 mm should be available above the unit to allow access for maintenance.

Figure 5 Air handling unit shown suspended.

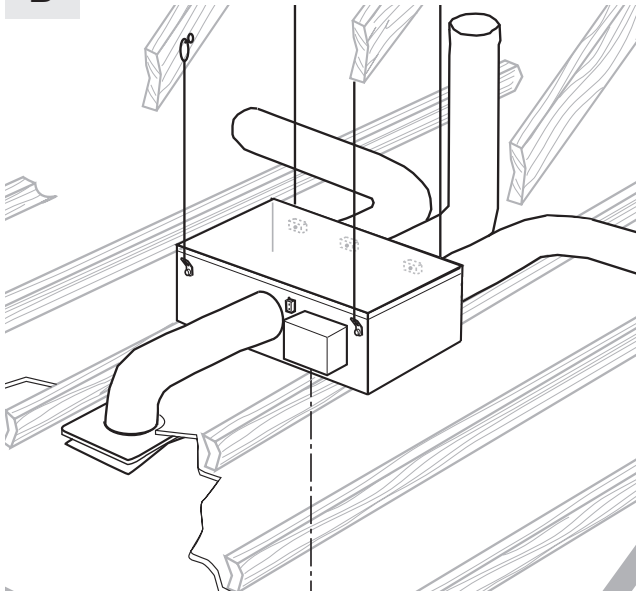

The air handling unit can also be mounted directly onto the roof joists using an AV mounting kit available from Nuaire (Part No. 771393).

Screw the battens (not supplied), to the unit via the 5mm dia. holes in the base under the filters, then lower complete onto the joists. (See Figure 6).

Mark and drill the 12mm dia. clearance holes required in the ends of the battens and place anti-vibration mounts above and below each batten fixing point. Using the four large screws and special washers, fix the unit to the joists.

Do not over tighten fixings. The distance from the top washer to the joist when installed must not be less than 50mm.

Figure 6 Air handling unit shown mounted on roof joists using AV mounts.

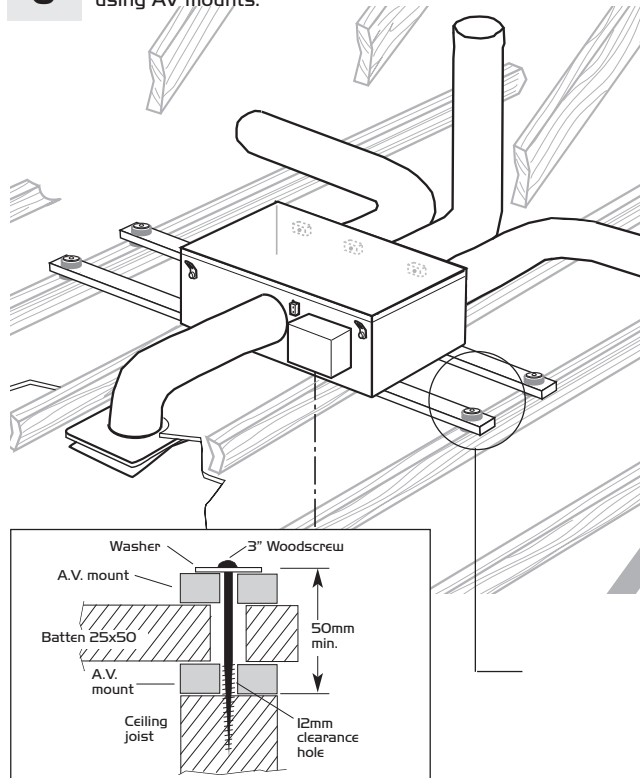

3.0 Installation of the Air Handling Unit and Associated Components

3.2 Unit air outlet connection

The main fan single air outlet spigot should be connected to the diffuser spigot using a length of 200mm diameter insulated ducting and dynotie connector, both supplied by the installer.

3.3 Unit air inlet and associated sensor connections

As explained previously the unit is capable of drawing in external air from different roof locations via three air inlet spigots each fitted with their own low energy open/close damper. Air inlet connections are made as follows:

1. Connection to Solar Collectors

- a) Use the four self tapping screws supplied to connect each spigot to inlet and outlet holes of collectors, making sure you use the spigot with pre-connected sensor in one of the outlet locations.
- b) Using 200mm insulated duct and dynotie straps (supplied by installer) connect the two inlet holes together through a Tee Piece (supplied) and then onto the filter box as shown in figure 8.
- c) Repeat step b) above for outlet holes and connect using 200mm insulated duct (supplied by installer) to one inlet spigot of the air handling box as shown in figure 9.

2. Connection to loft (see figure 10)

3. Connection to outside

- a) The soffit through a grille and ducting supplied by the installer (see figure 11) or:
- b) A wall grille and ducting supplied by the installer. (see figure 12) or:
- c) Roof tile vents by others and ducting supplied by the installer. (see figure 13).

Figure 8

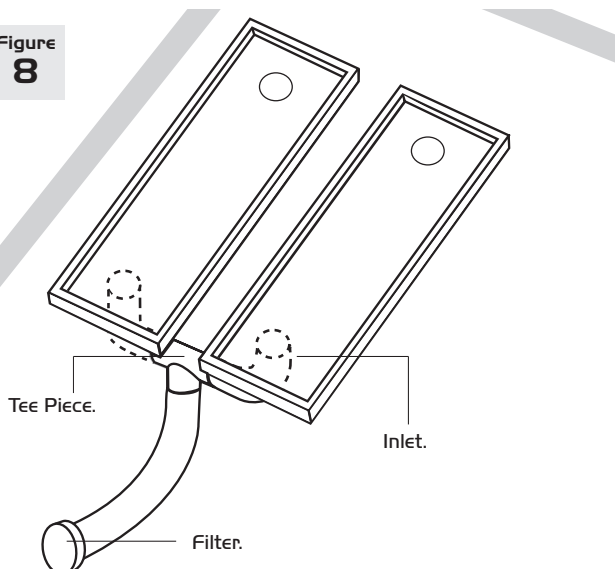

The following installation materials, not supplied with the unit, can be purchased separately by the installer direct from Nuaires' distributor, Fans Direct.

Tel: 08705 121400 Fax: 08705 121444.

E-mail: info@fansdirect.co.uk

Part No	Description
PVC 933WH	3m length of 222mm x 90mm flexible PVC ducting for use on soffit inlets (See figure 11). This length should be sufficient for 3 average installations.
518920	128mm x 260mm soffit grille (See figure 11).
FDC 200	200mm duct connector for connecting 222 x 90 flexible duct to 200 dia. insulated duct. (See figure 12).
SAVD6-EG	199 x 215 x 20mm white plastic wall grille. (See figure 12).
SAVD6-WALL	150mm dia. pipe for wall grille (See figure 12).
541044	Dynotie Zip ties, used for connecting 200mm ducting to spigots. 8 off should be sufficient for all types of installation.
FLDI 200	5m length of 200mm dia. insulated ducting.
FLD 200	5m length of 200mm dia. un-insulated ducting.
O11740	200mm dia. outlet spigot. For use with "Fireblock" (See figure 4).
771393	AV mounting kit (See figure 6).

Please note that Nuair do not supply any timber for the AV mounts.

Typical installation details of each of the aforementioned air inlet arrangements using the material above are detailed on the following page. The installer may use alternative materials to those above.

In these circumstances Nuair cannot take responsibility for their suitability.

3.0 Installation of the Air Handling Unit and Associated Components

Figure 9

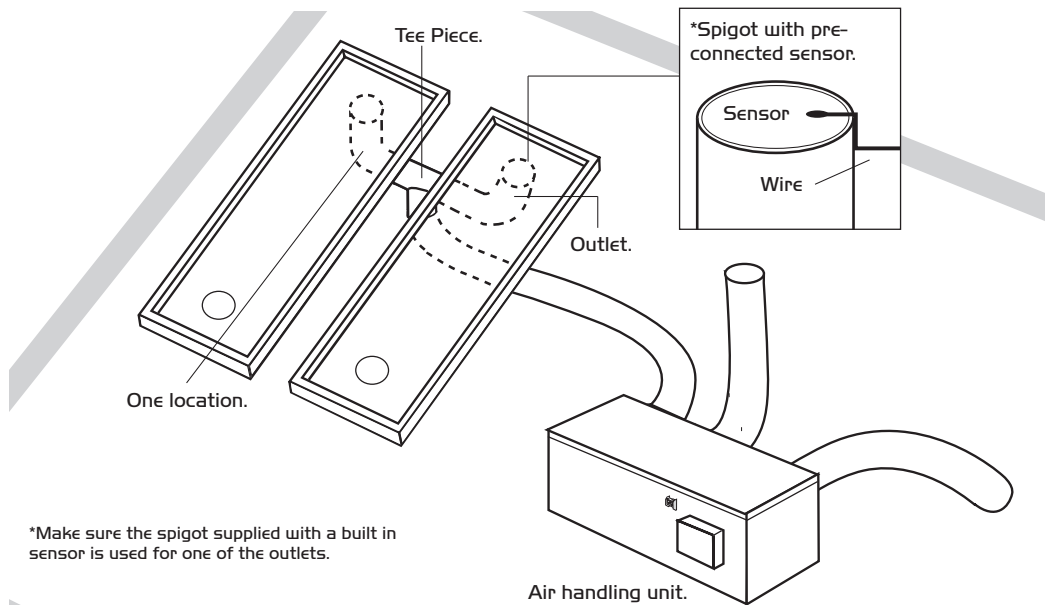

3.4 Via the loft space at high level through uninsulated ducting supplied by the installer

Figure 10

200mm dia. uninsulated duct (min 1.5m extended) secured to roof timber using large washer and screw (supplied by installer) inside throat of duct. Ideally the inlet to the duct should be located approximately 600 mm down from the highest point in the loft. Note: the ducting may be turned through 90° to obtain the minimum 1.5m extended length.

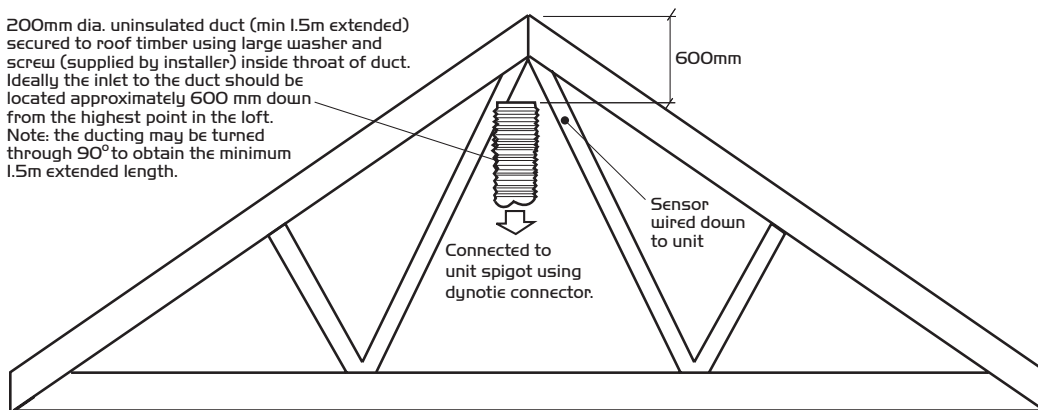

3.5 Via the soffit through a grille and ducting supplied by the installer

Figure 11

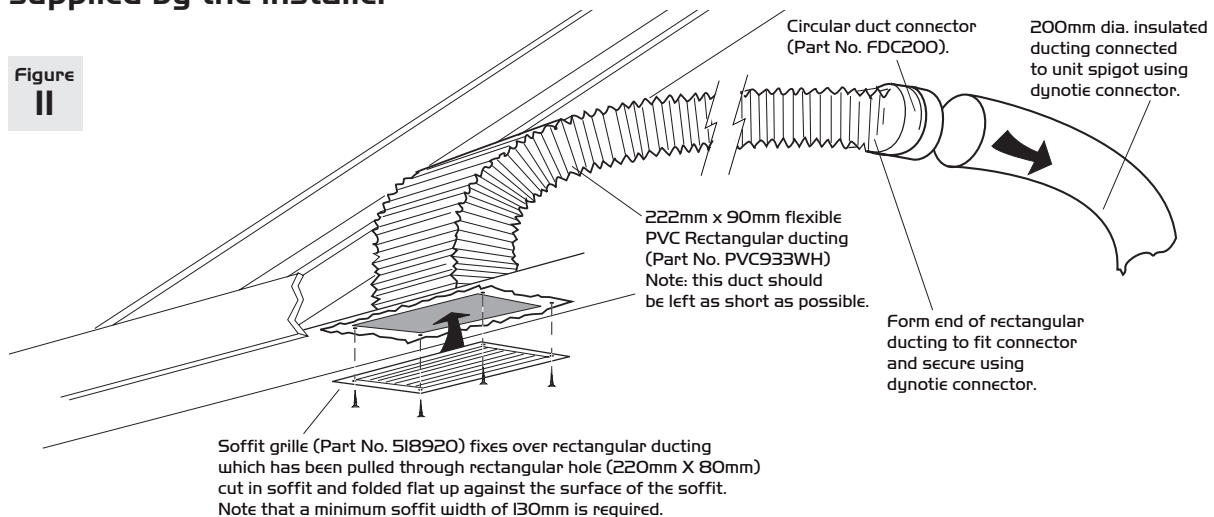

3.0 Installation of the Air Handling Unit and Associated Components

3.6 Via a wall grille and ducting supplied by the installer

Figure 12

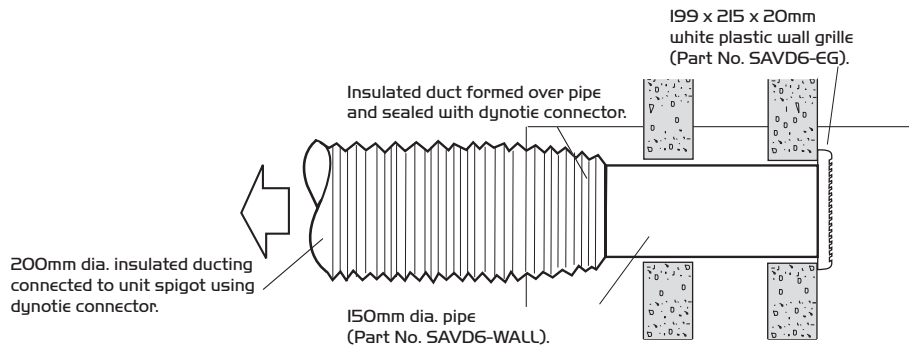

3.7 Via roof tile vents by others and insulated ducting supplied by the installer

Figure 13

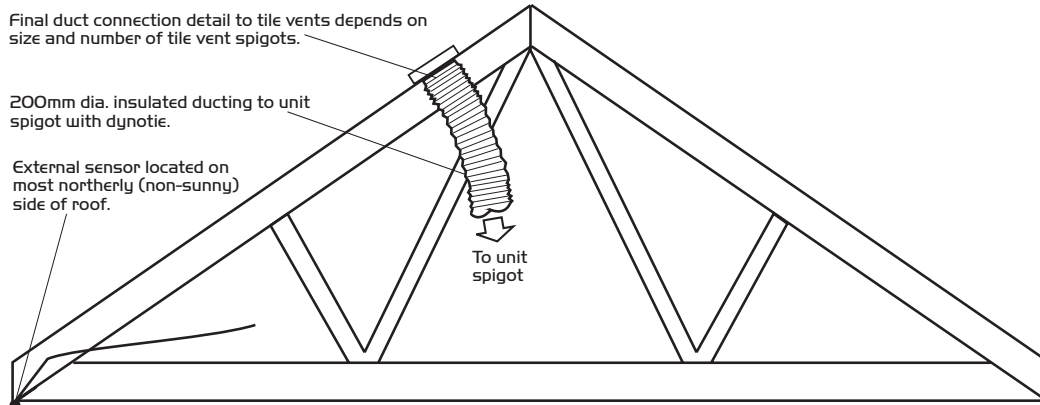

3.0 Installation of the Air Handling Unit and Associated Components

3.8 Connecting the temperature sensors to the unit

Supplied with the unit are three black leads each incorporating a temperature sensor which is sealed at one end.

The sensor end of the leads connected to connection 1, 2 and 3 (see figure I4) should be located as follows:-

- i) Measuring the outside air temperature.
(See figures I1, I2 and I3).
- ii) Measuring Solar Collector temperature.
This sensor is supplied pre-connected to spigot
(See figure 9).
- iii) Measuring loft temperature.
(See figure I0).

With the cable sensors installed as described above, attach the other ends of the cables to the appropriate connector block on the main unit.

Fit the fourth temperature sensor in a suitable location in the home.

Select a position unaffected directly by heating radiators or possible draughts from opening windows. Using a small screwdriver, pierce a hole in the corner of the ceiling and push the end of the sensor through until it just protrudes into the room.

Connect the other end of the sensor cable to the fourth connector block (Figure I4).

Figure
I4

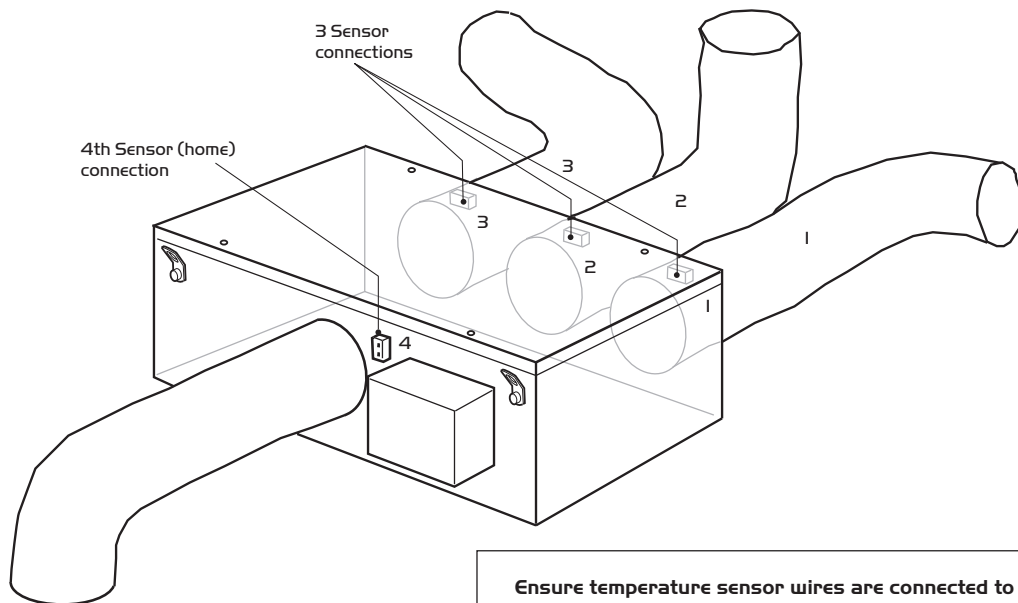

Ensure temperature sensor wires are connected to their respective plugs adjacent to duct spigots.

4.1 Electrical Connection

Please note: the electrical connection of the unit must be carried out by a qualified electrician.

Electrical details:-

Voltage: 240V Iph 50Hz

Consumption: 40W (max)

Fuse rating: 3 Amp

NOTE This unit must be earthed

The three core cable from the mains power supply should be connected to a fixed wiring installation, via a fused isolator, in accordance with current IEE wiring regulations.

4.2 User Control

The user control should be fitted to an appropriate wall (fixings supplied). Position the control so that the user can gain easy access. Instructions for fixing are supplied with the control.

Screw the backplate to the wall. Connect the cable (supplied) and clip the control into place. Route the cable to the left and connect to the main unit control module panel (see figure 16).

Secure the cable to prevent accidental dislocation.

Figure 15

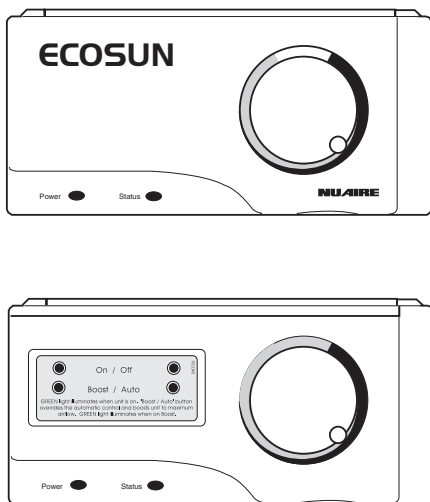

User Control Test

Ensure the power light is on green and the status light is either green or amber.

If the power light is not on check the wiring and connections between the fan unit and the user control.

The user control as shown in figure 15 above, has a target temperature setting dial knob and two press buttons (under the flap) which enable the fan to be switched off or the airflow to be boosted to its maximum duty.

Figure 16

Control module panel on unit (cover removed).

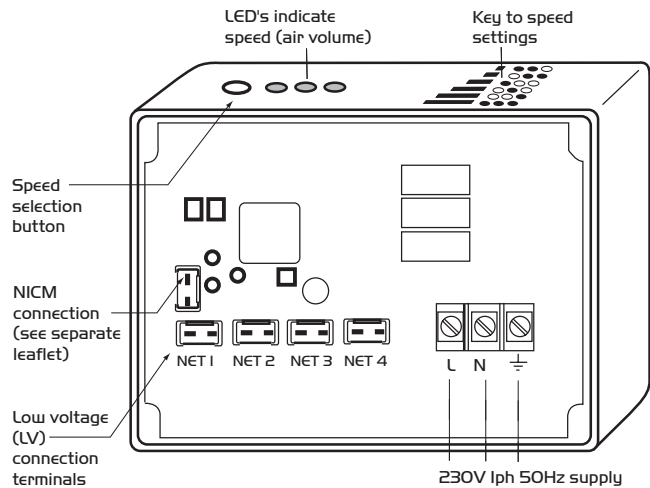

4.3 Airflow Adjustment on fan unit

The unit has six air volume (speed) settings. The setting switch is located on the main control box on the fan case.

Figure 16 shows the LED's that, when illuminated, indicate the corresponding air volume for the unit.

For example, a one bedroom, one person bungalow would be adjusted to the lowest setting (two LED's on the left illuminated).

A five bedroom seven person detached house would need to be set to the highest (all three LED's illuminated).

With power connected the three LED's will flash randomly for approximately 2 minutes and will then indicate the speed currently set. To select another speed, simply continue to press the button down until the required setting is shown.

5.0 Dimensions and Maintenance

5.1 Dimensions (mm) and weight

Figure 17

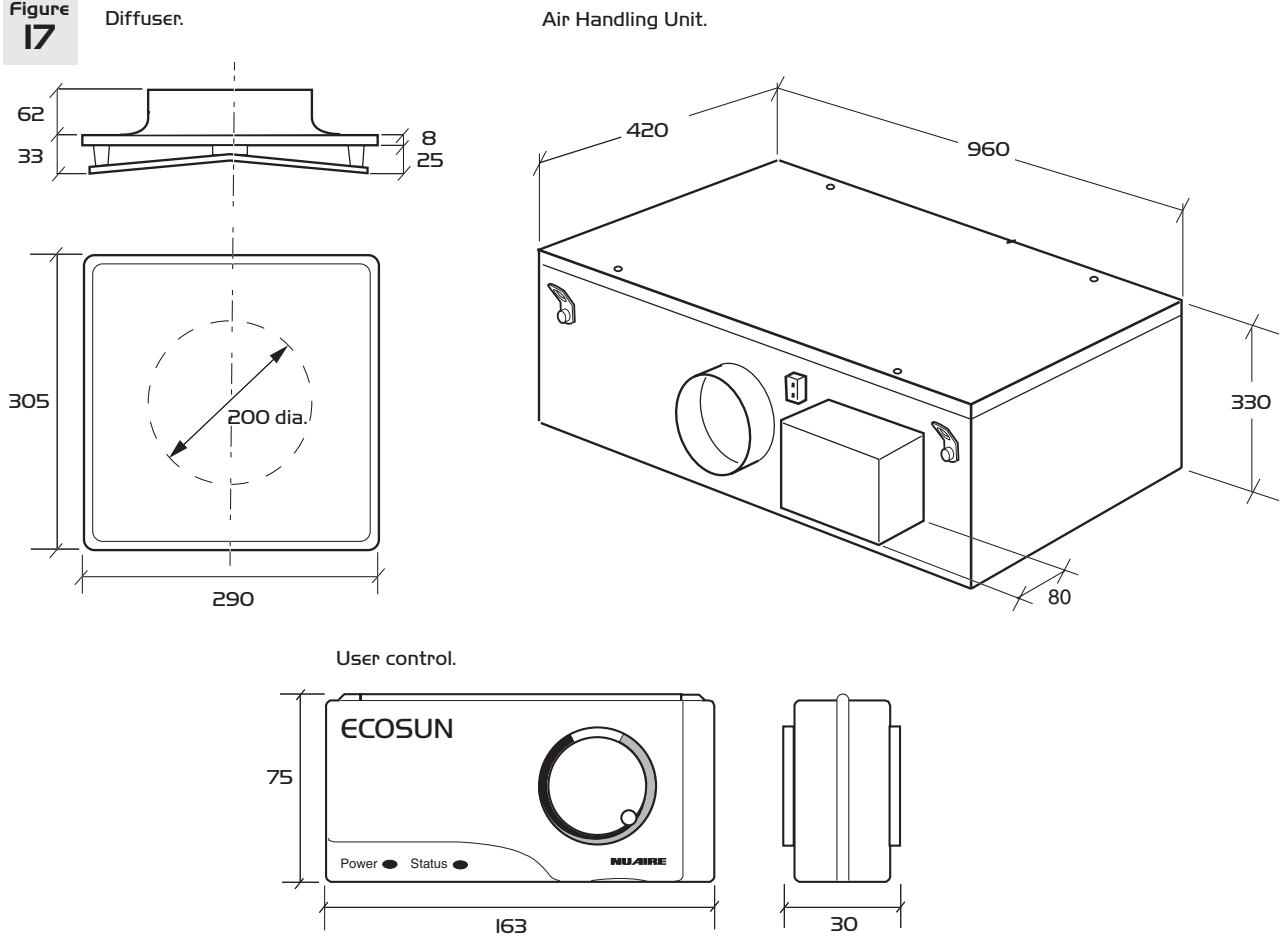

5.2 Maintenance

The unit does not require any maintenance other than a filter change and a check of electrical connections every 5 years. The status light on the user control panel will flash red when a filter change is required.

New filters can be purchased direct from Nuair using the following code: 040718 (5 year filter).

If the status light is permanently red, or if the units performance has been reduced dramatically and there is no flashing red light, please contact our service department.

Dust can occasionally accumulate through static, on the diffuser and the adjacent ceiling. This can be removed if required by vacuuming.

Note: A clear distance of 500mm should be available above the unit to allow access for maintenance.

5.3 Warranty

The units 5 year warranty starts from the day of delivery and includes parts and labour.

5.4 Service Enquiries

Nuair can assist you in all aspects of service. Our service department will be happy to provide any assistance required initially by telephone and If necessary arrange for an engineer to call.

Telephone 029 2085 8441

Technical or commercial considerations may, from time to time, make it necessary to alter the design, performance and dimensions of equipment and the right is reserved to make such changes without prior notice.

www.sunwarm.com

Your local Sunwarm/Ecosun representative.

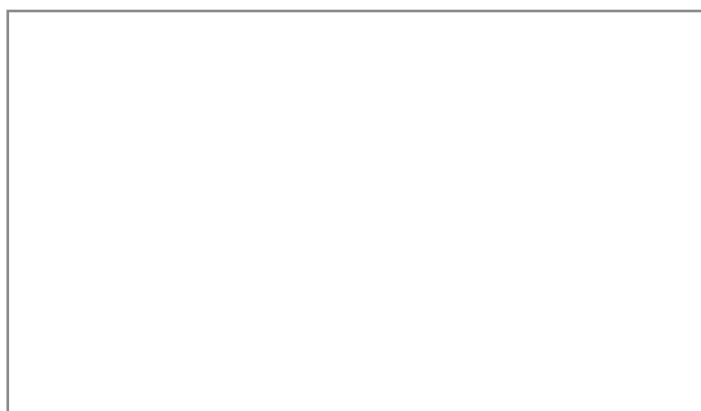

Nuaire Limited. • Western Industrial Estate • Caerphilly • CF83 1NA • United Kingdom

Manual Number 671276 January 05