

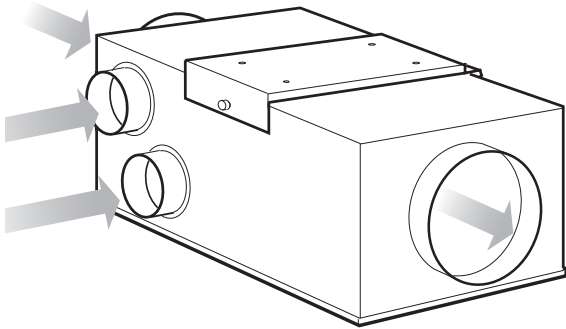

Opus 100-M & 150-M Duct Mounted Extract Fans Installation and Maintenance

Figure 1. General view of unit showing airflow.



Introduction

Manufactured in galvanised steel, the unit is designed to serve toilets, store rooms, small offices, restaurants, smoking areas etc. and for duct mounting applications usually in the ceiling or service voids above the areas served. For full specification, dimensions and weights etc. refer to catalogue page 169.

Opus fan range

Code	Description	Power/ FLC at full speed
OPUS 100-M	A single fan unit	100W/0.39A
OPUS 100-2M	A twin fan unit with run and standby and auto duty share	100W/0.39A
OPUS 150-M	A dual fan unit with both motors running	200W/0.78A

Installation

The installation must be completed by competent persons in accordance with good industry practice and should conform to all governing and statutory bodies i.e. IEE, CIBSE, COHSE, HVCA etc.

The unit comprises a full length access cover, to reveal filter and fans and is supplied with outlet spigot fitted and 'knockouts' to be removed at the chosen inlet positions.

Prepare the unit for installation by removing the access cover, all internal packaging and the fan assembly (which is supplied loose in the box). Replace the unit cover and knock out the chosen inlet spigot points and fit the matching spigots.

Ensure that all electrical and ducting services are compatible to the installation and the desired control function.

Mechanical installation

Select a solid non-reverberant mounting position, remove the unit support bracket and fix the bracket to the chosen structure with appropriate anchor bolts or screws.

The fan can be installed using the integral mounting bracket supplied (Figure 2). Offer the unit to the bracket as shown and secure into position with the one point-fixing bolt.

Connect inlet and outlet ducting.

Figure 2.

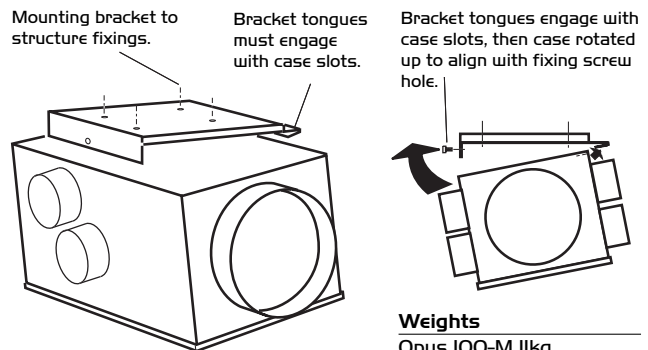

Weights

Opus 100-M	11kg
Opus 150-M	12kg

Electrical installation

Offer the single phase supply wiring, 230v switched live wire and the wires of any externally installed sensors or controls via the case side grommets.

Notes

- To ease electrical connection, remove the six-way termination block
- The mains wiring must be from a fixed wiring installation and both mains and switched live must be connected via a common local isolator
- The earth wire must be connected to the earth post provided and not to the six-way termination block
- Refer to remote sensor data sheets for their installation and connection

Figure 3. Wire for full speed operation only.

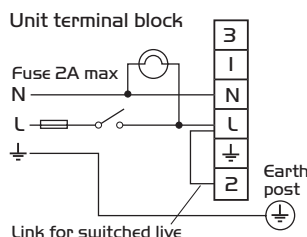
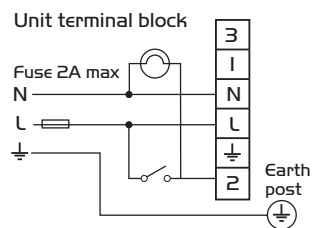

Figure 4. Wire for trickle vent/boost and timed overrun.



Nuaire Limited Western Industrial Estate Caerphilly United Kingdom CF83 1NA
Telephone: 029 2085 8200 Facsimile: 029 2088 7033
Email: info@nuaire.co.uk www.nuaire.co.uk

Installing and removing the blowers and control module

Figure 4. Removing the impeller transit-packing pieces (1 and 2).

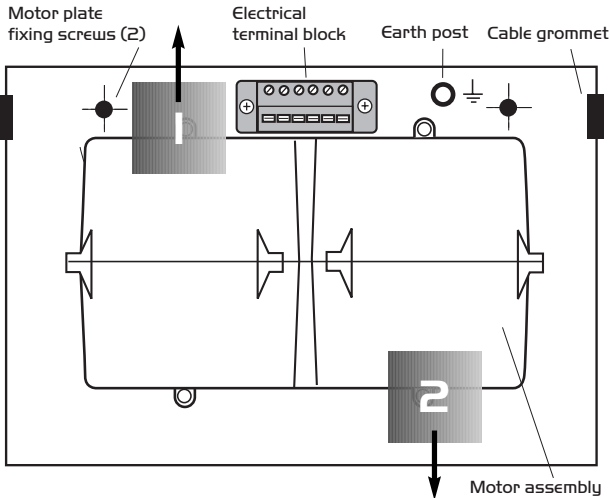

Remove the cover and withdraw the 'V' shape filter from the case. Lift out the loose blower assembly, remove the two motor retaining screws (A) which will be used to fix the motor plate into position. Tilting the top of the mounting plate forwards, locate the bottom of the plate into the channel provided in the case (C). Swing up the motor flush with the plenum (B) and secure with the two fixing screws (A). Expand 'V' shape filter and fit into case.

Figure 5. Fitting/removing the motor plate assembly.

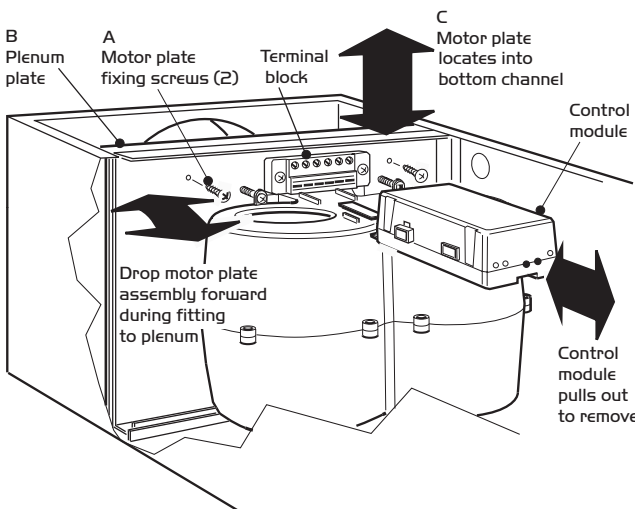

Finally locate the control module in to the blowers moulded guides and push the module in to the terminal block, ensuring that spade connections are engaged. Connect the motor plugs and remote status indicators (if used) to the sockets in the control module.

Turn on mains power and test run the unit.

Setting to work

All the control functions and adjustments are located on the electronic control module. An adjusting tool is provided clipped to the blower casing.

Figure 6. Electronic control module adjustments.

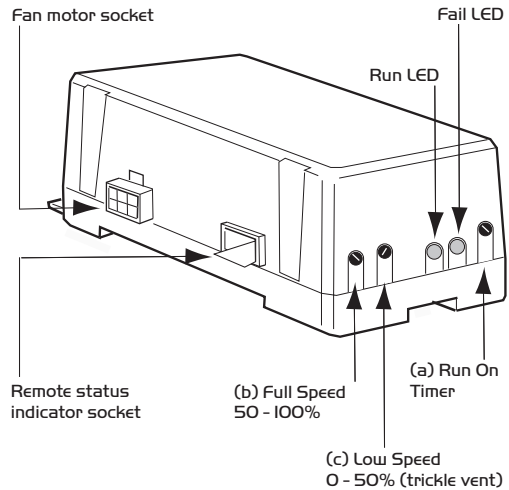

(a) Setting the run on timer

The overrun feature is only active when the fan is connected to a switched live as in wiring diagram 3. The overrun time is factory set at zero, fully anti clockwise and can be adjusted up to thirty minutes by turning the adjustment clockwise. Test by activating/deactivating the switched live circuit.

(b) Setting the full (MAX) speed

The full/MAX speed is factory set at 100%, fully clockwise and can be adjusted down to 50% (fully anti clockwise) by adjusting the setting screw anti clockwise with the setting tool supplied.

(c) Setting the low (MIN or trickle) speed

The low or trickle speed is factory set at zero, fully anti clockwise and can be adjusted upwards to a maximum of 50% speed by turning the adjusting screw clockwise with the setting tool supplied.

Note; the fan has to be wired as diagram 4 and activated via the switched live for the trickle (low speed) to boost (max speed) to be operative.

Maintenance

Maintenance should only be completed by competent persons in accordance with good industry practice and should conform to all governing and statutory bodies i.e. IEE, CIBSE, COHSE, HVCA etc.

Before removing covers ensure that all electrical services (including the switched live) are fully isolated from the mains supply.

The fan should be examined three months after commissioning and, dependent on the level of contamination present, at six monthly intervals thereafter.

Remove the filter and wash in tepid water with a mild detergent added, shake out excess water and allow to dry naturally. Do not replace until dry.

Remove the blower assembly as Figure 5. Inspect all parts and take care to retain all control settings, with a brush or dry cloth remove all dirt and debris from the fan plate and case, lightly brush away all dirt and debris from the fan assembly.

Reassemble the unit and test/run.

Optional external sensors and controls

Refer to the appropriate data sheet for installation and usage details.

Device	Code	Data sheet ref.
PIR sensor	230-PIR NT	670610
Thermostat	OPUS+TSTAT	670988
Humidistat	OPUS+HUMISEN	670987
Remote speed control	OPUS-SPD	671219
Audio visual fault indicator	CT-AVI	670986
Volt free status indicator	OPUS100/150VF	671197

Replacement of parts

Nuaire keep extensive stocks of spares for quick delivery, when ordering please clearly identify the part required and quote the product code, serial number and ARC number from the fan rating label.

3 Year Warranty

The three-year warranty starts from the day of delivery and includes parts and labour for the first year, the remaining two years cover parts only. The warranty is conditional on planned maintenance being undertaken and the presentation of rating plate details.

Service Enquiries

Nuaire can assist you in all aspects of service. Our service department will be happy to provide any assistance required, initially by telephone and if necessary arrange for an engineer to call.

Telephone 029 2085 8585
Fax 029 2085 8586

CE DECLARATION OF CONFORMITY





Nuaire Limited Western Industrial Estate
Caerphilly United Kingdom CF83 1NA
Telephone: 029 2088 5911
Facsimile: 029 2088 7033
Email: info@nuaire.co.uk www.nuaire.co.uk

**We declare that the machine named below
conforms to the requirements of EC Council Directives
relating to Electromagnetic Compatibility and
Safety of Electrical Equipment.**

Designation of machinery:	OPUS EXTRACT FANS
Machinery Types:	OPUS 100-M, OPUS 100-2M, OPUS 150-M
Relevant EC Council Directives:	89/336/EEC, 92/31/EEC (EMC) 73/23/EEC, 93/68/EEC (Low Voltage Directive)
Applied Harmonised Standards:	EN55014-1, EN55014-2, EN60204-1, EN60335-2-80
Basis of Self Attestation:	Quality Assurance to BS EN ISO 9001 BSI Registered Firm Certificate No. FM I49

Signature of manufacture representatives:

	Name:	Position:	Date:
1) 	C. Biggs	Technical Director	23. 8. 03
2) 	W. Glover	Manufacturing Director	23. 8. 03

Technical or commercial considerations may, from time to time, make it necessary to alter the design, performance and dimensions of equipment and the right is reserved to make such changes without prior notice.