

Mark Ten

Belt Drive Roof Mounted Extract Fans Installation and Maintenance

CE The EMC Directive 2004/108/EC
The Low Voltage directive 2006/95/EC

Introduction

Of monocoque construction and manufactured in aluminium alloy, the fans are designed for roof mounted applications only - air inlet at the bottom and discharge at the top. Available in impeller diameters of 400 to 1000mm - unit codes 400MT to 1000MT. The unit incorporates aluminium mixed flow impeller, integrated bird guard and gravity backdraught shutters, the motor is out of airstream coupled to the fan shaft with vee section belt drive assembly.

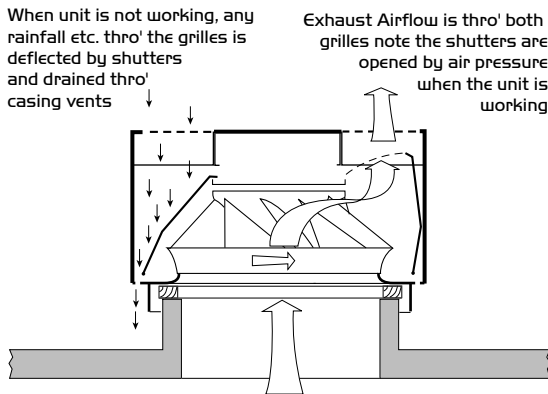
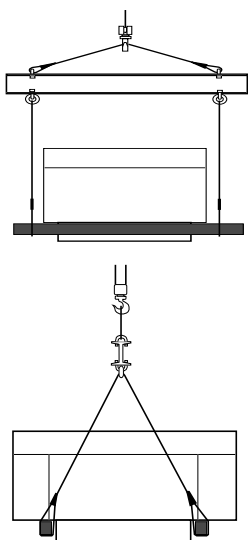

Figure 1. Section view of unit

The drive assembly is supported on resilient mountings. Every unit is tested and serialised at works, and a test certificate is produced, the details recorded on the fan rating plate. Refer to the details on this plate before handling and installation.

Figure 2.



Handling

Always handle the units carefully to avoid damage and distortion, if mechanical aids are used to lift the unit, spreaders should be employed and positioned so as to prevent the slings, webbing etc. making contact with the unit.

Please Note: to prevent unnecessary strain during transit, clamping pieces have been clamped between the drive assembly and the base - these packing pieces are painted red. Do not remove them until the unit has been secured to its base and under no circumstances run the unit until they have been removed.

Coding

630 MT 2 / 2
 Impeller Size | Mark Ten | Performance Curve | I = Single Phase 2 = Three phase

Unit Dimensions

Figure 3.

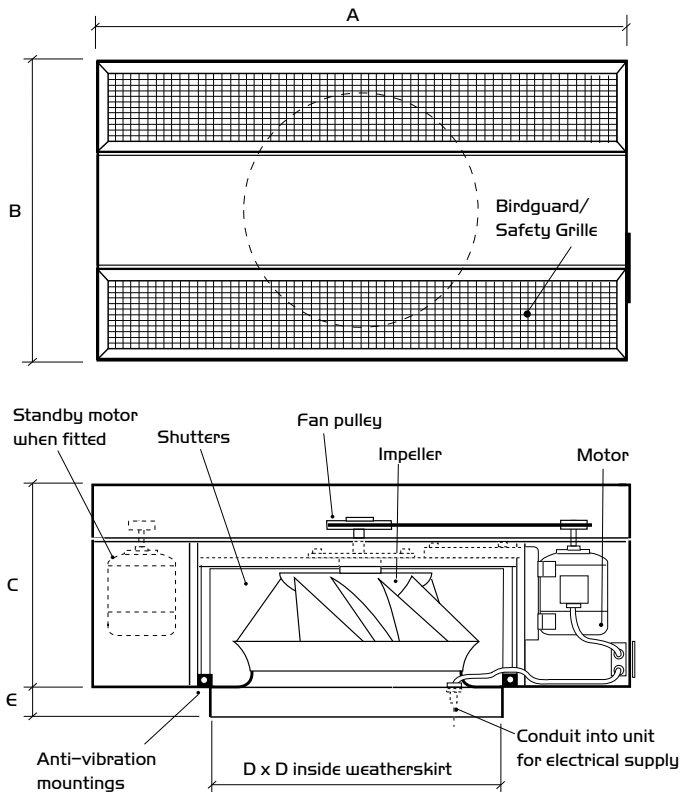

Dimensions (mm) and weights

Unit size	A	B	C	D	E	Weight kg excl. motor
400 MT	1100	615	323	490	50	29
500 MT	1350	784	443	590	75	33
630 MT	1350	784	443	690	75	50
800 MT	1735	890	535	790	75	96
1000 MT	1967	1125	618	1040	75	150

Installation

The installation must be carried out by competent personnel in accordance with good industry practice and the appropriate authority and should conform to all statutory and governing regulations i.e. CIBSE, HVCA, IEE, COSHE etc.

Figure 4. Curb Dimensions

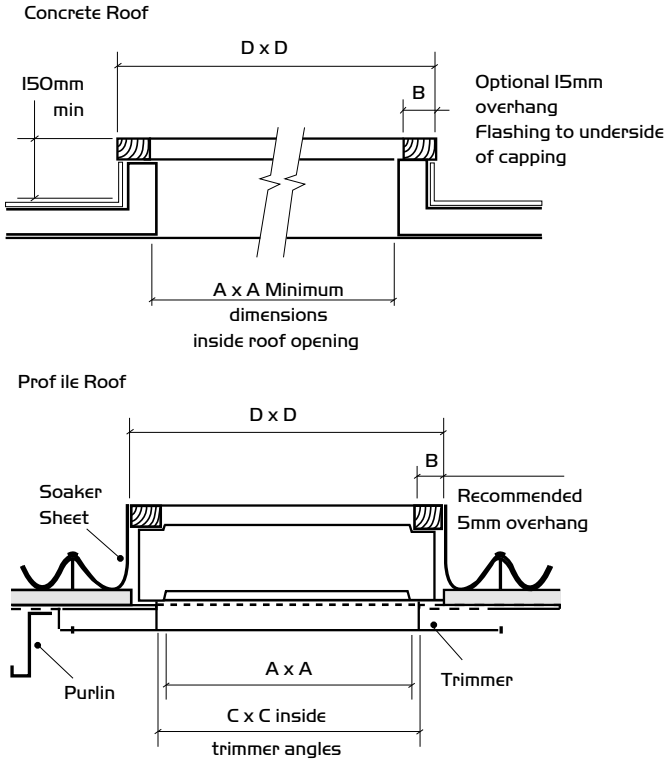

Note: All wooden curbs and caps to be hardwood or treated softwood of minimum 50mm thickness. (supplied and fitted by others).

Table of curb dimensions (mm)

Unit size	A	B	C	D
400 MT	300	75	375	480
500 MT	400	75	475	580
630 MT	500	75	575	680
800 MT	600	75	675	780
1000 MT	800	100	900	1030

Fixing

The unit must be securely fixed to its curb/upstand to prevent vibration and wind damage. Two fixing holes are provided on each side of the weather skirt to allow direct contact with the timber capping of curb/upstand. Use non corrosive fixings.

Ensure the red packing pieces are removed from the fan base when installation is complete.

Pitched Roof

The pitch angle must not exceed 5° and the unit must be mounted with the longer side running up and down the roof slope to ensure satisfactory operation of gravity shutters.

Figure 5.

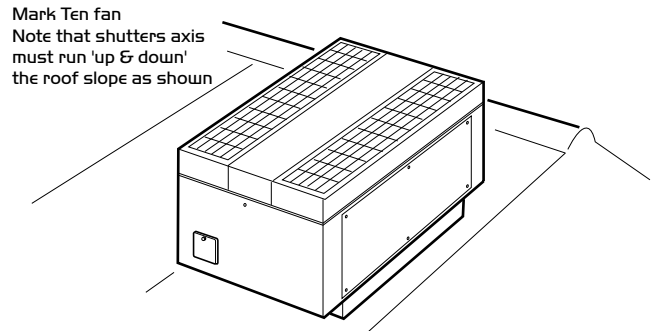

Prefabricated Curb

Matched to each unit and manufactured in galvanised steel and capped with a sealant tape. When installed the curb must be securely bolted to the trimmer angles.

Figure 6. Prefabricated Curb Dimensions

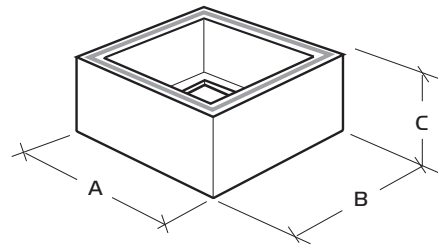

Unit size	P.F. Curb	A	B	C
400 MT	400 PFC/1	450	450	250
500 MT	500 PFC/1	550	550	250
630 MT	630 PFC/1	650	650	250
800 MT	800 PFC/1	750	750	250
1000 MT	1000 PFC/1	1000	1000	250

Soaker Sheet

GRP soaker sheets (1950mm long) are available to match most roof profiles. Each sheet is placed over the prefabricated curb, trimmed to height and built into the roof in accordance with standard building practice.

Figure 7.

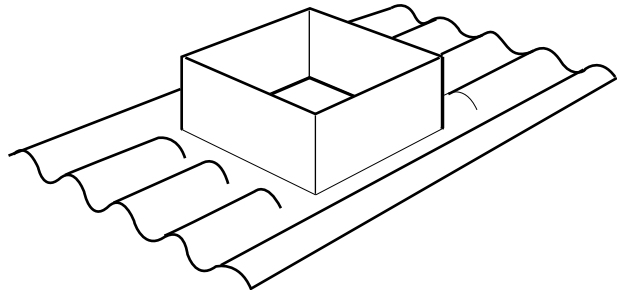
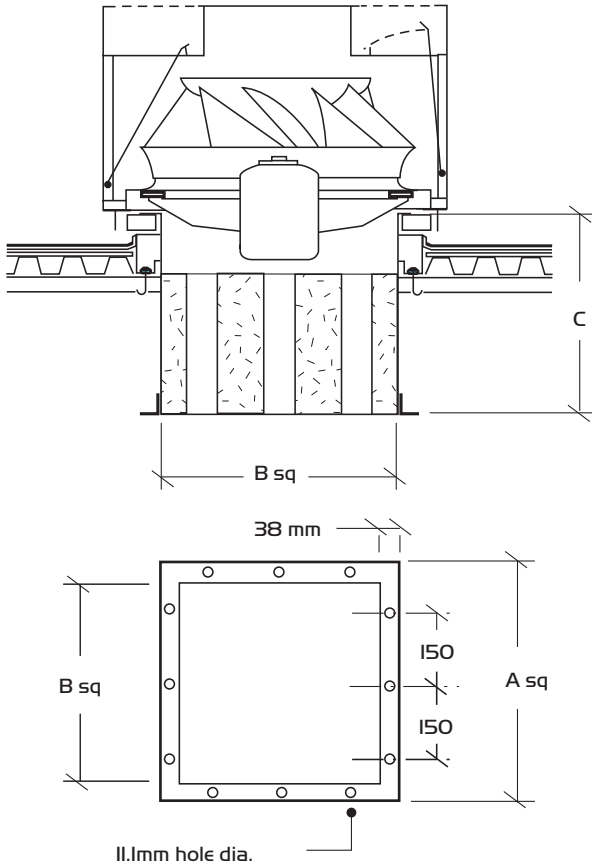

Figure 8. Quiet Curb Dimensions



Quiet Curbs (Attenuators)

Matched attenuators, manufactured in galvanised steel incorporate a detachable flange to ease installation and connection to extension attenuators and ducting.

Do not lift by passing slings or ropes through the attenuator airways.

Dimensions (mm) and weights for quiet curb

Unit	Unit Code	Type	A	B	C	No. of	
						Holes	Weight
400 MT	QC40S/1	Standard	356	280	600	8	16kg
500 MT	QC50S/1	Standard	456	380	670	12	30kg
630 MT	QC63S/1	Standard	556	480	825	16	46kg
800 MT	QC80S/1	Standard	656	580	720	16	53kg
1000 MT	QC100S/1	Standard	856	780	720	24	66kg

Unit	Unit Code	Type	A	B	C	No. of	
						Holes	Weight
400 MT	QC40L/1	Long	356	280	1050	8	21kg
500 MT	QC50L/1	Long	456	380	1120	12	40kg
630 MT	QC63L/1	Long	556	480	1275	16	74kg
800 MT	QC80L/1	Long	656	580	1170	16	85kg
1000 MT	QC100L/1	Long	856	780	1170	24	104kg

Electrical Details

IMPORTANT

For good EMC engineering practice, any sensor cables or switched live cables should not be placed within 50mm of other cables or on the same metal cable tray as other cables.

Isolation - Before commencing work make sure that the unit, switched live and Nuaire control are electrically isolated from the mains supply.

Units are not supplied with electrical isolators, their selection and provision is the responsibility of the installer.

The electrical wiring enters the unit via the ductwork/curb opening and a 20mm conduit adapter in the baseplate, the wiring is to be terminated in the termination box on the baseplate. Start and run currents are dependent on fan/system duty and performance, this table therefore quotes nominal values for guidance. Note the fan rating plate and test certificate details when sizing electrical wiring, control panel, overloads etc.

This data is based on 230v 1 Ph and 400v 3Ph 50Hz supplies. Start Currents (SC) are the peak instantaneous values for DOL starting.

Standard motors are pre-wired to the internal base mounted termination box. Explosion proof motors (flameproof or EXD type motor) are to be wired directly to the motor termination box with the appropriate cable by the installer.

All three phase motors of 4KW and above are suitable for direct on line (DOL) starting or connection to a Star/Delta starter. The six motor terminal ends are wired from the motor to the termination box and it is for the installer to link

the wires in DELTA for direct on line starting or to connect them to the six terminals of the Star/Delta starter.

Two speed three phase motors are of the PAM or Tap Wound and require a three contactor starter control, the six motor terminal ends are wired to the termination box for connection to the correct control.

Standby motors, where fitted, are also wired to the base mounted termination box and require independent isolation. In normal use both motors should be powered, with standby motor drive belt uncoupled to prevent brinelling of the bearings and condensation build up in the motor.

Single phase belt drive fans are not speed controllable. Three phase belt drive fans are only speed controllable by a frequency inverter variable speed drive. The installer is strongly advised to observe and follow the guide lines and advice given in the frequency inverter installation instructions.

Motor - Electrical Data

Motor kW	230v 1 phase 50Hz		400v 3 phase 50Hz	
	flc	sc	flc	sc
0.18	1.50	3.90	0.65	2.40
0.25	2.00	6.50	0.90	3.40
0.37	2.50	7.50	1.10	4.50
0.55	3.30	10.50	1.50	6.50
0.75	-	-	2.80	9.80
1.10	-	-	3.30	13.20
1.50	-	-	3.70	18.50
2.20	-	-	5.40	27.00
3.00	-	-	6.90	37.95
4.00	-	-	8.80	48.40
7.50	-	-	15.70	95.77

Wiring Diagrams

1 phase single speed

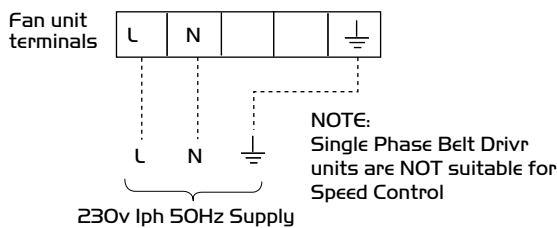

3 phase single speed (below 4kW)

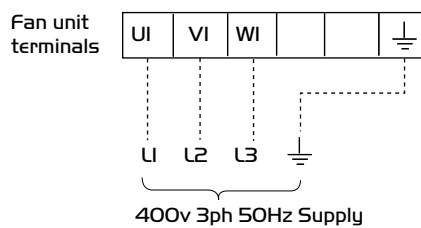

3 phase DOL starting and connection to frequency inverter (4kW and above)

400V 3 phase 50Hz supply

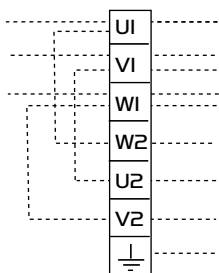

For D.O.L. (Direct On-Line Starting) operation or Inverter type Speed Control, wire in DELTA (△)

3 phase for connection to Star/Delta starter (4kW and above)

400V 3 phase 50Hz supply

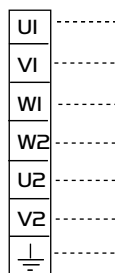

2 speed TAP/PAM wound motor (DOL starting both speeds)

Note: individual wiring instructions are included with each unit

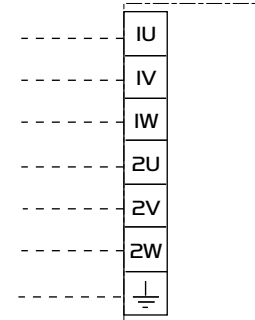

NOTE:
LOW SPEED - Supply: IU IV IW
HIGH SPEED - Supply: 2U 2V 2W & link IU IV IW

△ 400V 3 phase 50Hz supply

Maintenance

IMPORTANT

Isolation - Before removing any panels ensure the unit is isolated.

Maintenance should be carried out on a regular basis, we recommend three months from commissioning and at least annually thereafter as determined by the operating conditions and levels of airborne contamination to which the unit is exposed.

To ease and facilitate maintenance, the top centre panel, discharge grillages and long side panels are removable. Upon re-assembly ensure that backdraft shutters are free to move

Figure 9. Access for maintenance

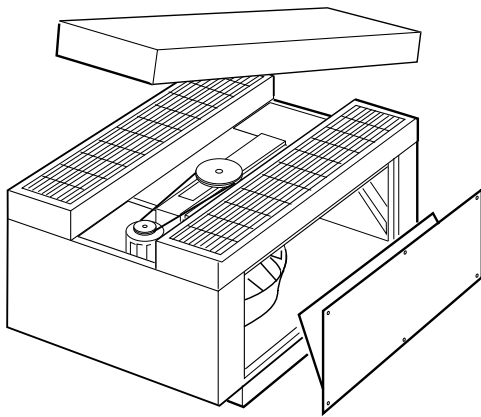

Bearings

Lubrication is unnecessary as the motors are fitted with sealed for life bearings.

Belt Tensioning

Belt tensioning is facilitated by releasing the motor cradle pinch bolts and slide outwards, replace belts if wear is evident and where more than one belt is employed replace them all. Belt wear is usually associated with a maladjusted belt or misaligned pulleys - if found adjust accordingly.

Figure 10. Belt/Pulley adjustment

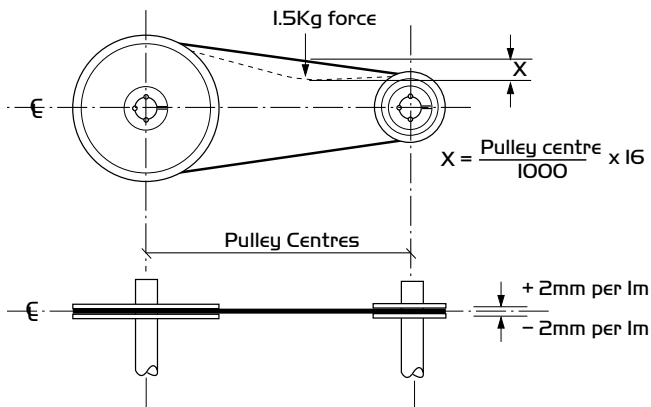

Impellers

Impellers are dynamically balanced during manufacture, no special treatment is required during maintenance, other than to clean and remove all dust and dirt residue, taking care not to disturb the balance weights. Remove stubborn dirt with warm soapy water - do not use caustic fluids.

To remove the impeller and fan bearing; Remove the locking nut at the top of the shaft and release the full nut until it reaches the top of the shaft. Tap it smartly downwards to release the tapered collet at the bottom of the shaft. Remove the bearing flange fixing screws, lift the bearing out from the bridge section and the impeller from below the bridge section.

Figure 11. The impeller, bearing and pulley

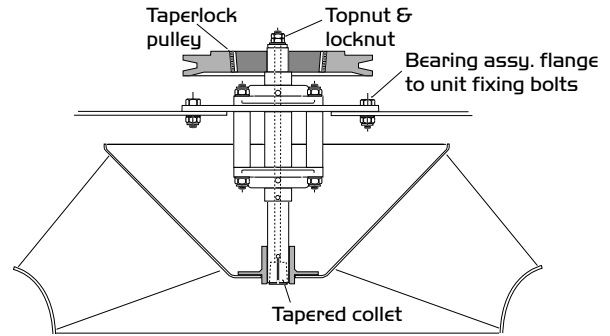

Reverse the process to re assemble ensuring minimum clearance between Impeller and inlet venturi whilst maintaining free rotation.

Drive Pulleys

Drive pulleys are secured via a taper locking bush. Should it prove necessary to remove a pulley, remove the protective paint from pulley, the shaft and the grub screws 1 and 2 as shown in figure 12. Insert one of the grub screws into hole C and tighten. Pulley, bush and shaft will separate.

To reassemble, clean all the surfaces of the taperlock bush and the inner surface of the pulley, loosely offer grub screws A & C, position the bush/pulley assembly on the shaft, align drive and driven pulley with a straight edge and tension.

Figure 12. Removing and fitting the Taperlock pulley

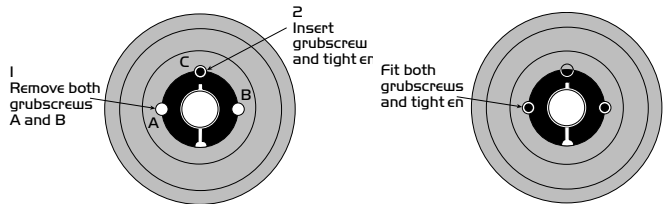

Warranty

The 3 year warranty starts from the day of delivery and includes parts and labour for the first year. The remaining 2 years covers replacement parts only. This warranty is conditional on planned maintenance being undertaken.

Service Enquiries

Nuaire can assist you in all aspects of service. Our service department will be happy to provide any assistance required, initially by telephone and if necessary arrange for an engineer to call within 48 hours if possible.



Telephone 029 2085 8585
Fax 029 2085 8586

DECLARATION OF INCORPORATION AND INFORMATION FOR SAFE INSTALLATION, OPERATION AND MAINTENANCE

We declare that the machinery named below is intended to be assembled with other components to constitute a system of machinery. The machinery shall not be put into service until the system has been declared to be in conformity with the provisions of the EC Machinery Directive.

Designation of machinery: Roof Mounted Extract Fan
Machinery Types: MARK TEN
Relevant EC Council Directives: 98/37/EC as amended by 98/79/EC (Machinery Directive)
Applied Harmonised Standards: BS EN ISO 12100-1, BS EN ISO 12100-2, EN294, EN60204-1, BS EN ISO 9001
Applied National Standards: BS848 Parts One, Two and Five

Signature of manufacture representatives:

Name:	Position:	Date:
1) C. Biggs 	Technical Director	20.07.07
2) W. Glover 	Manufacturing Director	20.07.07

INFORMATION FOR SAFE INSTALLATION, OPERATION AND MAINTENANCE OF NUAIRE VENTILATION EQUIPMENT

To comply with EC Council Directives 98/37/EC Machinery Directive and 2004/108/EC (EMC).

To be read in conjunction with the relevant Product Documentation (see 2.1)

1.0 GENERAL

- 1.1 The equipment referred to in this Declaration of Incorporation is supplied by Nuairé to be assembled into a ventilation system which may or may not include additional components.
 The entire system must be considered for safety purposes and it is the responsibility of the installer to ensure that all of the equipment is installed in compliance with the manufacturers recommendations and with due regard to current legislation and codes of practice.

2.0 INFORMATION SUPPLIED WITH THE EQUIPMENT

- 2.1 Each item of equipment is supplied with a set of documentation which provides the information required for the safe installation and maintenance of the equipment. This may be in the form of a Data sheet and/or Installation and Maintenance instruction.
 2.2 Each unit has a rating plate attached to its outer casing. The rating plate provides essential data relating to the equipment such as serial number, unit code and electrical data. Any further data that may be required will be found in the documentation. If any item is unclear or more information is required, contact Nuairé.
 2.3 Where warning labels or notices are attached to the unit the instructions given must be adhered to.

3.0 TRANSPORTATION, HANDLING AND STORAGE

- 3.1 Care must be taken at all times to prevent damage to the equipment. Note that shock to the unit may result in the balance of the impeller being affected.
 3.2 When handling the equipment, care should be taken with corners and edges and that the weight distribution within the unit is considered. Lifting gear such as slings or ropes must be arranged so as not to bear on the casing.
 3.3 Equipment stored on site prior to installation should be protected from the weather and steps taken to prevent ingress of contaminants.

4.0 OPERATIONAL LIMITS

- 4.1 It is important that the specified operational limits for the equipment are adhered to e.g. operational air temperature, air borne contaminants and unit orientation.
 4.2 Where installation accessories are supplied with the specified equipment eg. wall mounting brackets. They are to be used to support the equipment only. Other system components must have separate provision for support.
 4.3 Flanges and connection spigots are provided for the purpose of joining to duct work systems. They must not be used to support the ductwork.

5.0 INSTALLATION REQUIREMENTS

In addition to the particular requirements given for the individual product, the following general requirements should be noted.

- 5.1 Where access to any part of equipment which moves, or can become electrically live are not prevented by the equipment panels or by fixed installation detail (eg ducting), then guarding to the appropriate standard must be fitted.
 5.2 The electrical installation of the equipment must comply with the requirements of the relevant local electrical safety regulations.
 5.3 For EMC all control and sensor cables should not be placed within 50mm or on the same metal cable tray as 230V switched live, lighting or power cables and any cables not intended for use with this product.

6.0 COMMISSIONING REQUIREMENTS

- 6.1 General pre-commissioning checks relevant to safe operation consist of the following:
 Ensure that no foreign bodies are present within the fan or casing.
 Check electrical safety. e.g. Insulation and earthing.
 Check guarding of system.
 Check operation of Isolators/Controls.
 Check fastenings for security.
 6.2 Other commissioning requirements are given in the relevant product documentation.

7.0 OPERATIONAL REQUIREMENTS

- 7.1 Equipment access panels must be in place at all times during operation of the unit, and must be secured with the original fastenings.
 7.2 If failure of the equipment occurs or is suspected then it should be taken out of service until a competent person can effect repair or examination. (Note that certain ranges of equipment are designed to detect and compensate for fan failure).

8.0 MAINTENANCE REQUIREMENTS

- 8.1 Specific maintenance requirements are given in the relevant product documentation.
 8.2 It is important that the correct tools are used for the various tasks required.
 8.3 If the access panels are to be removed for any reason the electrical supply to the unit must be isolated.
 8.4 A minimum period of two minutes should be allowed after electrical disconnection before access panels are removed. This will allow the impeller to come to rest.
NB: Care should still be taken however since airflow generated at some other point in the system can cause the impeller to "windmill" even when power is not present.
 8.5 Care should be taken when removing and storing access panels in windy conditions.

Technical or commercial considerations may, from time to time, make it necessary to alter the design, performance and dimensions of equipment and the right is reserved to make such changes without prior notice.

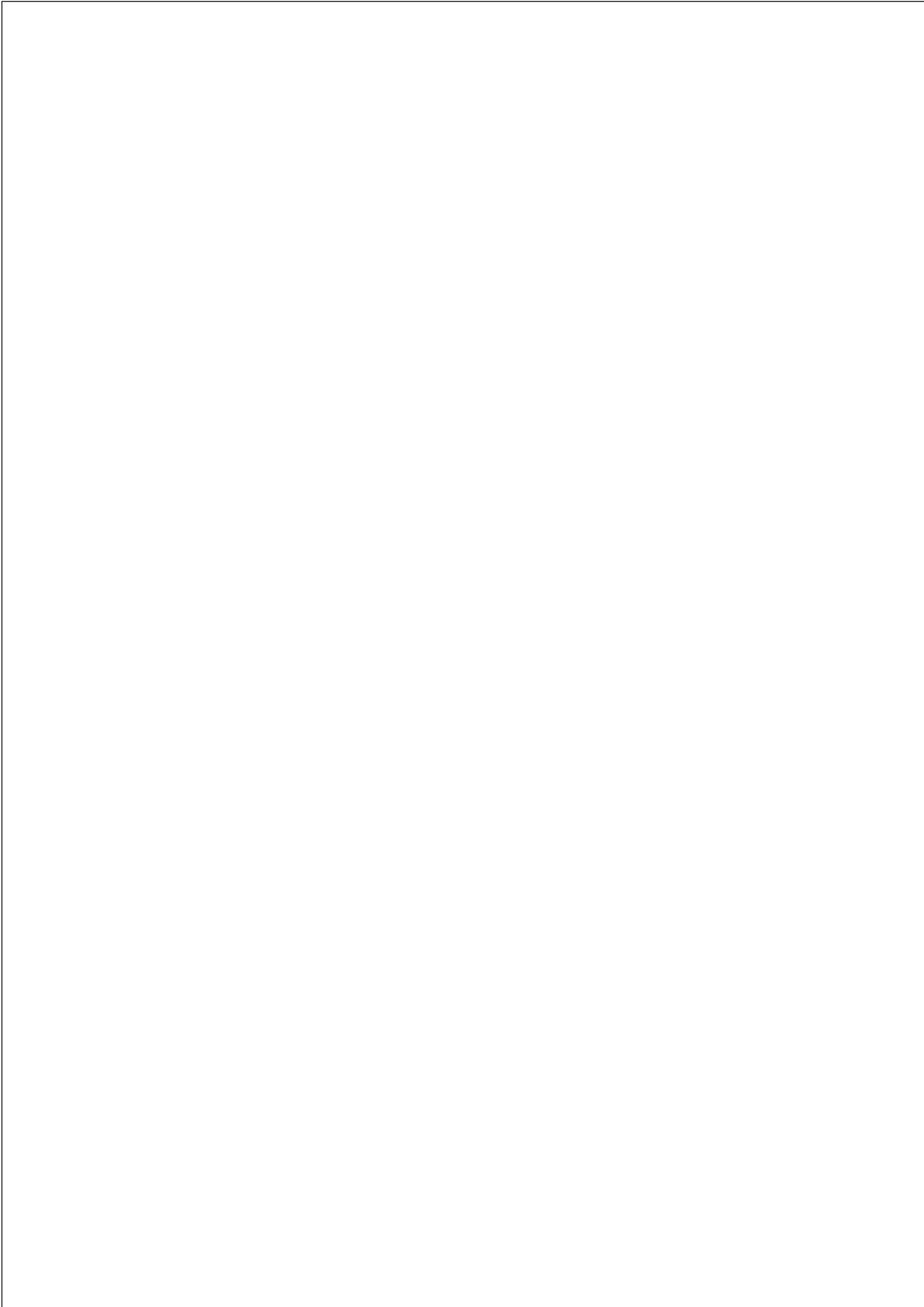



Western Industrial Estate
Caerphilly United Kingdom
CF83 INA
T: 029 2088 5911
F: 029 2088 7033
E: info@nuaire.co.uk
W: www.nuaire.co.uk