



Opus 30 and 60, 230V

Surface, Recessed & Duct Mounted
Domestic Extract Fans

Installation and Maintenance

CE The EMC Directive
2004/108/EC
The Low Voltage
directive
2006/95/EC

Opus Fans

The Nuair range of Opus 230V fans have been specifically designed to ventilate areas such as the bathroom, toilet, stores, drying rooms, cupboards etc. Mounting options include Surface/Semi-recessed, Recessed and Duct mounting.

The units discharge air through a 100mm diameter outlet spigot and have provision for adding a 50mm dia. subsidiary inlet to extract air from a second room.

Air entering the (B range - surface mounted) and (R range - recessed mounted) units passes through a washable filter fitted to the front cover. Anti-backdraught shutters, retained in the closed position when fan is not running, are fitted to the base plate. The (duct mounted M range) is designed to extract air through 100mm dia. pipe via a 50 or 100mm inlet grille.

Motor has sealed, self lubricating bearings and "heatseeker" thermal overload protection. The fan/ motor assembly is retained by spring clips to simplify maintenance.

As a safety feature the fan/motor assembly is automatically disconnected when the electronic control module is removed.

I.O Fan Installation

Installation must be completed by competent persons, in accordance with good industry practice and should conform to all governing and statutory bodies i.e. IEE, CIBSE, COHSE etc.

I.1 Surface Mounting Wall or ceiling (B range)

It is assumed that a solid non reverberant mounting position has been selected and passages for ductwork from the outlet spigot, to subsidiary inlet spigot (if a second room is to be ventilated) as well as electrical connection prepared. In addition compatible ductwork has already been installed.

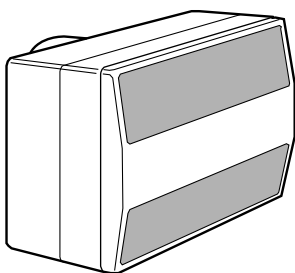

Figure I. General view of unit.

Figure 2B. Semi-recessed using fixing kit No.770984. (See figure 9. for installation of kit).

NB. Base drill pattern superimposed on page 2.

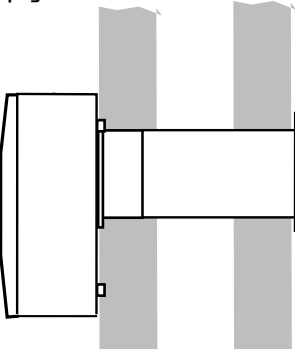
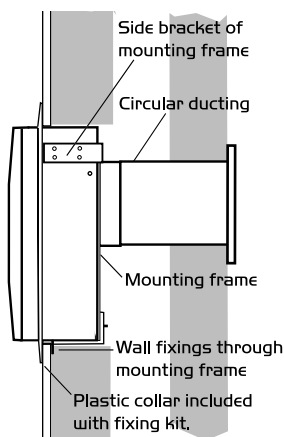

Figure 2A. Surface mounted in wall.



Isolation - Before commencing work make sure that the unit is electrically isolated from the mains supply.

1. Unpack the fan and separate the two halves of the unit by releasing the two clips on either side of the case. Release the two internal clips and remove the fan unit. (Figure 3). Remove the cover and filters which are packed separately and retain for

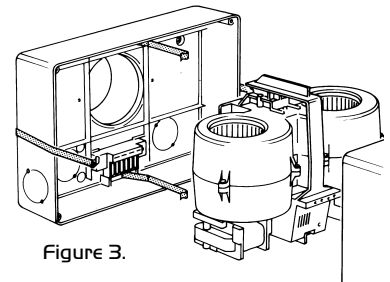

Figure 3.

later use. Use the base as a template and mark the discharge spigot and mounting holes onto the mounting surface.

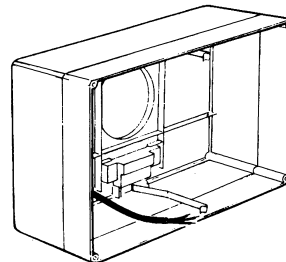

Figure 4. Cable entry.

2. Prepare the area and connect the base spigot to compatible ductwork. Secure to the surface taking care not to twist or distort the case by over tensioning whilst offering the appropriate supply cable through the selected cable entry.

3. Remove the electrical socket/terminal block from the case, then connect wiring to the internal terminal block socket.

4. If a second room is to be served, remove the circular weakened area in the case side, and pass the subsidiary inlet spigot through the hole from inside the case. Turn the spigot one quarter of a turn to lock. (Figure 5).

Note: Two room ventilation requires an optional subsidiary spigot kit- code OPUS-D-KIT. The kit incorporates a subsidiary spigot, inlet grille, flexible ducting and balancing plates.

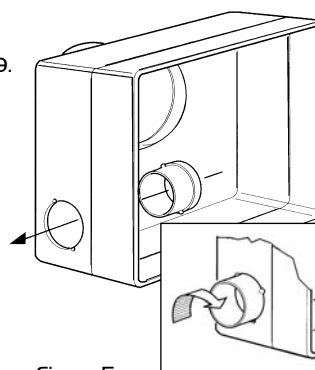
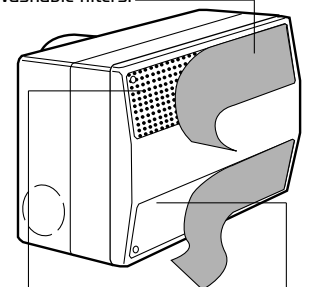

Figure 5.

Washable filters.



Perforated airflow balancing plate. Blank plate fitted to the bottom grille.
Figure 6. Fitting balancing plates.

5. Fit the fan module to the base, matching the plug to the internal socket. Ensure that the pull cord is passed through the case, (Figure 4) then secure via spring clips.

6. Complete the installation by securing the cover and fit filters into front cover recesses. Test run.

I.2 Recessed Mounting

Wall or ceiling (R range)

With optional fixing kit No. 770984

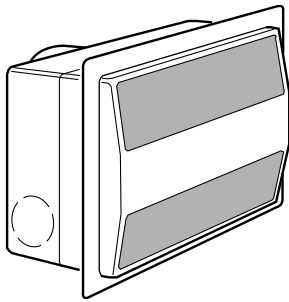

Figure 7. General view of Recessed unit.

1. An opening of 327mm wide x 245mm deep should be prepared in the surface mounting position to accept the fan case and fixing kit brackets.

2. The depth of the recess should be at least 25mm more than the dimension from the back of the unit to the rear face of the skirt.

3. Assemble the fixing kit mounting frame by attaching the three legs to the 'Y' shaped frame.

4. Position the assembled mounting frame into the prepared aperture, then trim the ends of the brackets so that they are flush with the wall. (See figure 5). Secure the brackets with suitable fixings (by others).

5. Offer up the casing of the fan to the mounting frame, inserting the fan outlet spigot through the hole in the frame into the end of the compatible ductwork and fix using tape (by others). Figure 9. Fix the fan case to the frame using the three screws supplied.

Note: Remaining installation procedures for recessed mounting are contained in points 1 - 6 for surface mounting installation.

Figure 8. Recessed mounted in wall.

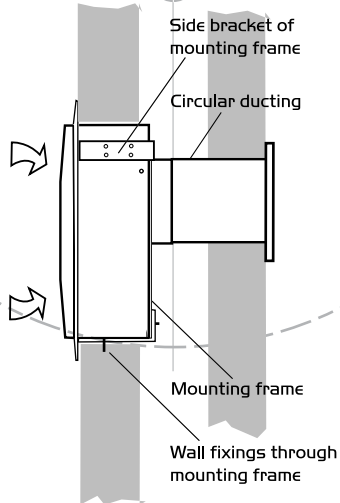

I.3 Installing into flat ducting

With optional fixing kit No. 770984

Note. It is assumed that the flat duct is already fitted with a plenum section incorporating a 100mm dia. spigot.

1. First proceed with installation procedures as recessed mounting description on fixing kit.

2. Feed the 100mm flexible ducting (supplied) through the rear of the mounting frame and fit to the spigot on the flat duct plenum.

3. Note: the remaining installation procedures for flat ducting mounting are as points 1 - 6 for surface mounting installation.

Isolation - Before commencing work make sure that the unit is electrically isolated from the mains supply.

Figure 9. Recessed/Semi-recessed frame kit mounted in wall aperture.

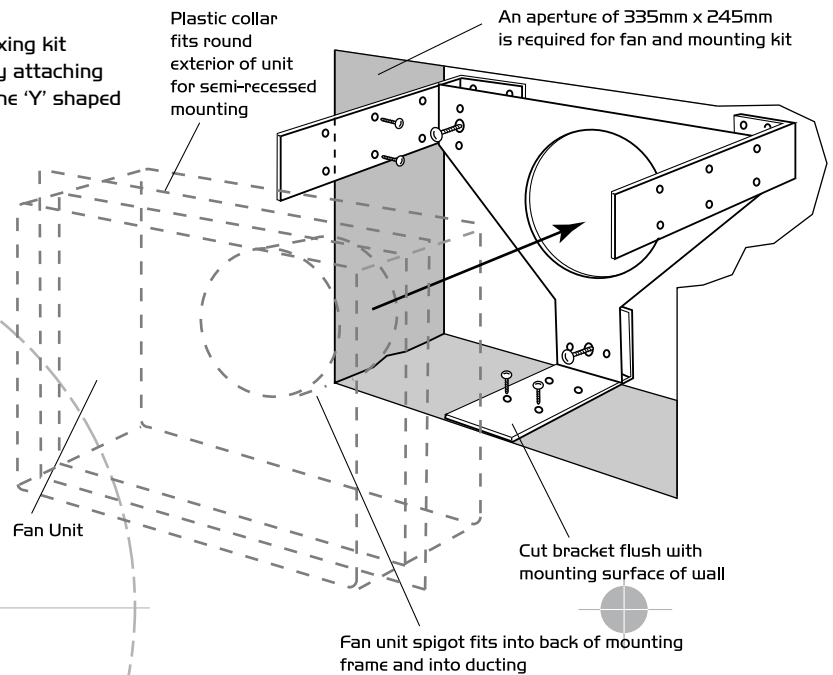
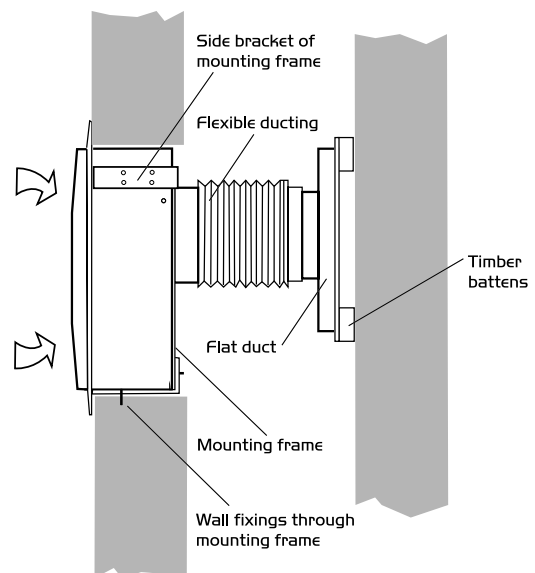
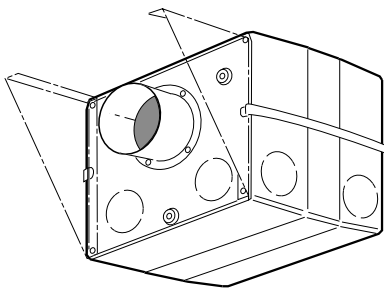

Figure 10. Flat duct installation.



I.4 Duct Mounting

Figure II. General view of duct unit.



It is assumed that a solid non reverberant mounting position has been prepared inside the duct passage area and the necessary ductwork already installed with adequate clearance on the inlet side to allow fitting of the flexible ducting supplied with the unit. It is also assumed that the electrical connections are in position and if a second room is to be ventilated, the ductwork for a subsidiary spigot has been made ready. (See surface mounting figures 5 and 6).

Note: When the unit is mounted in a vertical configuration it is important that the air flow is upwards so that the gravity operated shutters will work properly (see Figure I2c). For horizontally mounted units ensure that case is installed as shown in Figure I2a/b.

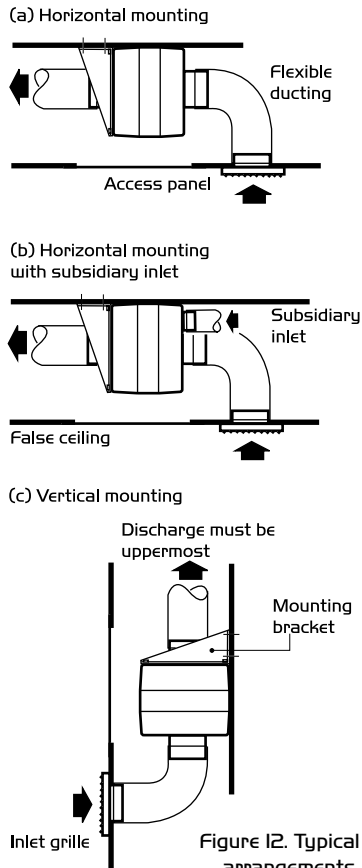

Figure I2. Typical arrangements, horizontal or vertical

1. Separate the two halves of the unit by releasing the two clips on either side of the unit. Release the two internal clips and remove the fan unit. Make ready for second room air extraction at this stage. See surface mounting details.

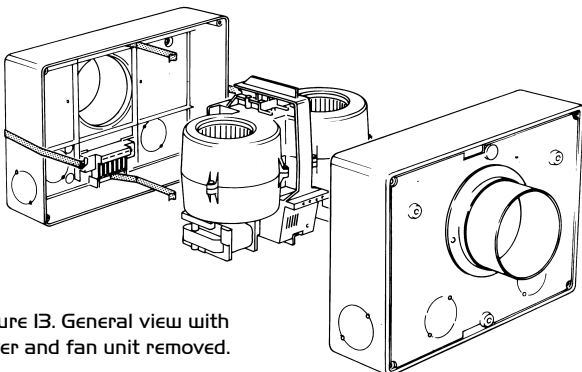
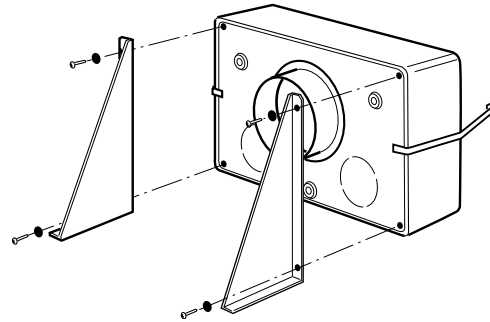

Figure I3. General view with cover and fan unit removed.

2. Fit the mounting brackets (supplied) to the portion of the case containing the wiring socket, using four self-tapping screws and washers supplied.

Figure I4. Fitting the mounting brackets.



3. Fit the one end of the flexible ducting to the spigot on one side of the cover. Figure I5.

Note: Remaining installation procedures for recessed mounting are contained in points 1 - 6 for surface mounting installation.

2.0 Coding

Surface Mounted (B) range

B	Basic unit with single fan.
BS	Single fan unit incorporating a run-on circuit.
BAS	Single fan unit incorporating both run-on and fan failure detection.
2BAS	Twin unit incorporating both run-on and fan failure detection/change over circuits.
BX	Single fan unit providing continuous low duty running with boost when room light is switched on. Opus 30 only.

Recessed Mounted (R) range

R	Basic unit with single fan.
RS	Single fan unit incorporating a run-on circuit.
RAS	Single fan unit incorporating both run-on and fan failure detection.
2RAS	Twin unit incorporating both run-on and fan failure detection/change over circuits.
RX	Single fan unit providing continuous low duty running with boost when room light is switched on. Opus 30 only.
No. 770984	Recessed frame kit.

Duct Mounted (M) range

M	Basic unit with single fan.
MS	Single fan unit incorporating a run-on circuit, adjustable between 5 - 30 mins.
MAS	Single fan unit incorporating both run-on and fan failure detection.
2MAS	Twin unit incorporating both run-on and fan failure detection/change over circuits.
MX	Single fan unit providing continuous low duty running with boost when room light is switched on. Opus 30 only.
OPUS-D-KIT	Subsidiary spigot kit.

Power Consumption

	Opus 30	Opus 60
Unit input power (watts)	26	83
Full load running current (amps)	0.170	0.69
*Starting Current (amps)	0.215	1.4

*On starting both fans run together.

3.0 Wiring details

isolation -
Before commencing work
make sure that the unit is
electrically isolated from
the mains supply.

For good EMC engineering
practice, any sensor
cables or switched live
cables should not be
placed within 50mm of
other cables or on the
same metal cable tray
as other cables.

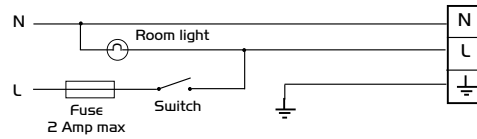

B/R/M Unit ventilating one room.

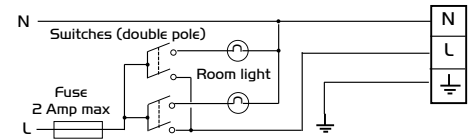

B/R/M/ Unit ventilating two rooms.

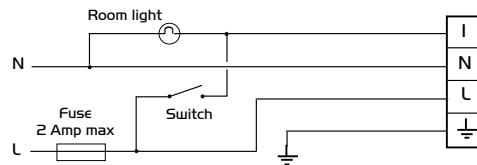

BS/RS/MS Unit ventilating one room (using run on circuit).

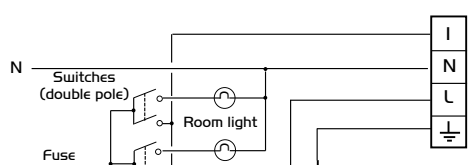

BS/RS/MS Unit ventilating two rooms (using run on circuit).

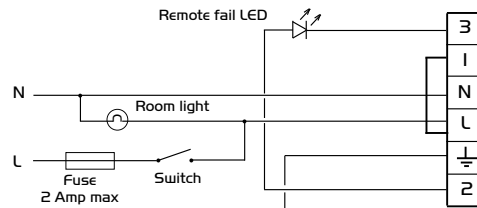

BAS/RAS/MAS/2BAS/2RAS/2MAS Unit ventilating one room (no run on timer).

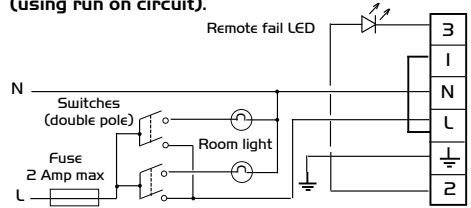

BAS/RAS/MAS/2BAS/2RAS/2MAS Unit ventilating two rooms (no run on timer).

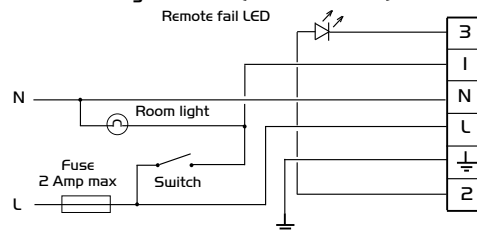

BAS/RAS/MAS/2BAS/2RAS/2MAS Unit ventilating one room (using run on circuit).

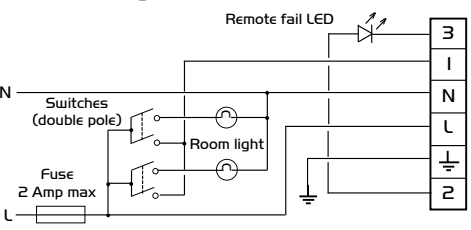

BAS/RAS/MAS/2BAS/2RAS/2MAS Unit ventilating two rooms (using run on circuit).

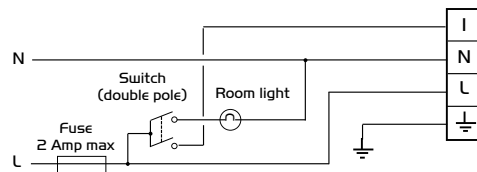

BX/RX/MX Unit continuous run with boost (Opus 30).

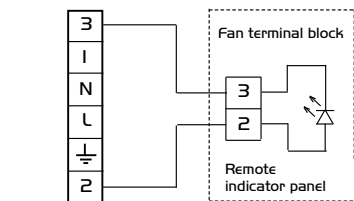

Wiring details for remote indicator.

4.0 Maintenance

General

A washable filter is fitted to protect the fan/motor assembly from towel lint, talc etc. and to prolong the life of the unit. However, some fine dust may find its way through the filter and could build up on the motor and/or impeller. It is therefore strongly recommended that all units are inspected and cleaned at least every six months.

Procedure

At all times take care not to damage, distort or disturb the balance of the impeller. Remove the filter and the electronic control module. Spring aside the two clips and remove the fan module. Inspect and replace any damaged items.

Using a soft brush or dry cloth remove dust and dirt from the fan module. Wash front cover in warm soapy water and dry thoroughly. Re-fit fan and electronic control module, replace front cover and secure with screws. Wash filter on tepid water to which a little mild detergent has been added. Shake out excess water and allow to dry naturally. Replace filter and refit the retaining screws. Test run the unit.

Replacement of Parts

Should any component need replacing Nuair keep extensive stocks for quick delivery. When ordering spare parts, please quote the serial number of the unit and the ARC number of the purchase if possible. **(This information will be available on the fan label).**

3 Year Warranty

The 3 year warranty starts from the day of delivery and includes parts and labour for the first year.

The remaining 2 years covers replacement parts only. This warranty is conditional on planned maintenance being undertaken.

Service Enquiries

Nuair can assist you in all aspects of service. Our service department will be happy to provide any assistance required, initially by telephone and if necessary arrange for an engineer to call.

Telephone 029 2085 8585
Fax 029 2085 8586

Technical or commercial considerations may, from time to time, make it necessary to alter the design, performance and dimensions of equipment and the right is reserved to make such changes without prior notice.