



Genie 12V and 230V Universal Surface Mounted Fans Installation and Maintenance

CE The EMC Directive
2004/108/EC
The Low Voltage
directive
2006/95/EC

Genie Fans

The Genie range of fans has been specifically designed to ventilate small rooms such as toilets, bathrooms, cloakrooms etc and can be surface and recessed mounting.

* An optional window mounting kit is available for this unit, code ref WINKIT.

Air entering the unit passes through a washable filter fitted to the front cover. Anti-backdraught shutters, retained in the closed position when fan is not running, are fitted to the base plate.

Motor has sealed, self lubricating bearings and "heatseeker" thermal overload protection. The fan/ motor assembly is retained by spring clips to simplify maintenance.

Interchangeable plug in electronic control modules can incorporate:

- Run - on timer
- Humidistat
- Continuous low duty with boost.

As a safety feature the fan/motor assembly is automatically disconnected when the electronic control module is removed.

Warning: when installing Genie units for remote switching it is important that the pull cord (if fitted) is removed.

It is recommended that the unit is switched off (by the pullcord) before cutting. Cut the pullcord inside the unit a little way beyond the control module.

Fan Installation

To be carried out by qualified personnel only.

Surface Mounting

Note. It is assumed that a solid mounting position has been selected and passages for ductwork from the outlet spigot, as well as electrical connection prepared. In addition that compatible ductwork has been installed.

Figure 1. Surface mounted, wall.

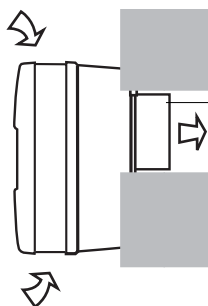

NB. Base drill pattern superimposed on page 2.

NB. The discharge spigot is 98mm od. The hole in the structure should therefore be of a dimension to accommodate any ducting or cavity lining used.

1. Remove cover/grille assembly by removing cover screws. Depress the top/bottom retaining tabs. (Fig. 2).

2. Remove the plug-in electronic control module. (Fig. 3).

3. Remove the fan/motor assembly by pulling aside the two spring clips.

4. Place the unit in the mounting position, connect the ductwork and feed the cable through the cable entry. Connect the wiring to the terminal block (it may be easier to temporarily remove the block to facilitate wiring).

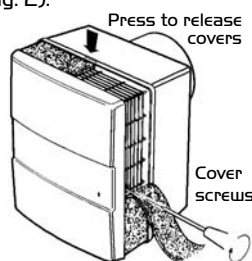

Figure 2.

IMPORTANT

Isolation - Before commencing work make sure that the unit is electrically isolated from the mains and switched live supply.

5. Drill and plug the mounting surface if necessary and secure the unit in position, using three No. 6 wood screws.

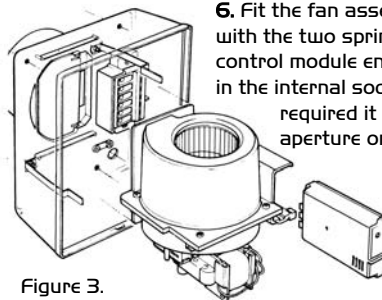

Figure 3.

6. Fit the fan assembly to the case, securing it with the two spring clips. Install the electronic control module ensuring that it is fully engaged in the internal socket. If the pull-cord option is required it should be fed through the aperture on the impeller housing before sliding the control module into place. (see fig. 6). If the pullcord option is not required it must be removed. Replace the front cover.

7. Fit the filter which is a push fit between the front cover and the body of the unit (see fig. 2).

8. Test run the unit noting that if a timer/humidistat option is fitted, the unit may run-on for the duration of the control sequence.

Semi-Recessed Mounting

Important note: Remove the shutters from the spigot if you are mounting the Genie in the ceiling.

Figure 4. Semi-recessed mounted, ceiling. First cut an aperture for the fan in the ceiling, cut and fit (A) timber supports (not supplied) and fit fan as shown.

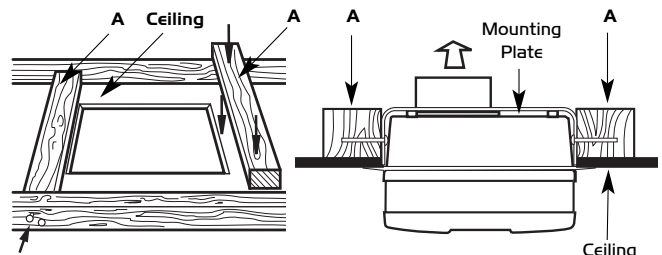
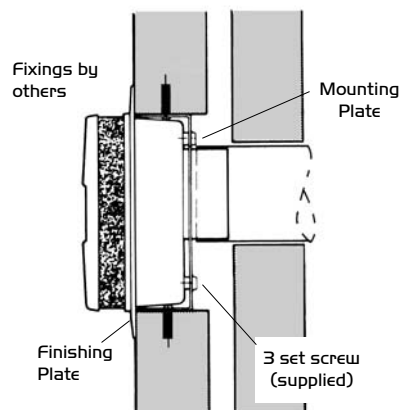

Figure 5. Semi-recessed mounted, wall.



IMPORTANT

Isolation - Before commencing work make sure that the unit is electrically isolated from the mains and switched live supply.

Semi-Recessed Mounting (cont).

Important note: Remove the shutters from the spigot if you are mounting the Genie in the ceiling.

1. Prepare an opening 184mm x 213mm. This will allow sufficient clearance (approx. 5 to 10mm) all around the unit to accept the fixing bracket (optional). Note. Do not exceed these dimensions, as an aperture larger than 208mm x 238mm will not be covered by the finishing plate.

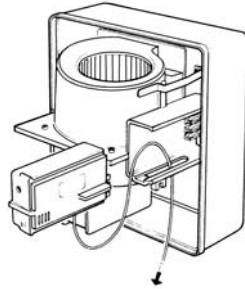

It is assumed that a solid, non-reverberant mounting position has been selected and the necessary compatible ductwork is already installed.

Figure 7.

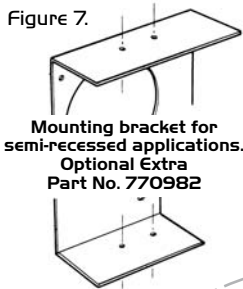

2. Position the mounting bracket (Fig.7) in the previously prepared aperture so that the ends of the bracket are flush with the surface of the wall. Secure the bracket with suitable fixings (by others) see Fig. 5. Note: Fit finishing plate to fan before securing to bracket.

Note: the remaining installation procedures for Semi-Recessed Mounting are as Surface Mounting description.

Window Mounting

WINKIT Parts checklist

The WINKIT contains the following parts. Make sure you have all the parts present before commencing installation.

1 off Outer Shutter frame assembly	011372 and 040547
1 off Outer gasket	540846
1 off Inner gasket	540845
3 off 5mm spacers	050149
3 off M4 x 12 Screws	680268
3 off M4 x 20 Screws	680087
3 off M4 x 30 Screws	680264
3 off M4 x 40 Screws	680265

The window mounting kit is designed for mounting the unit into windows 4mm to 32mm thick using a 125mm dia hole. (See figure 9).

Figure 8.

Top three shutter blades temporarily removed during installation.

Outer shutter frame.

Figure 9.

The hole in the glass should be 125mm dia. Centre 10mm to the left of the unit centreline and 70mm from the top of the unit.

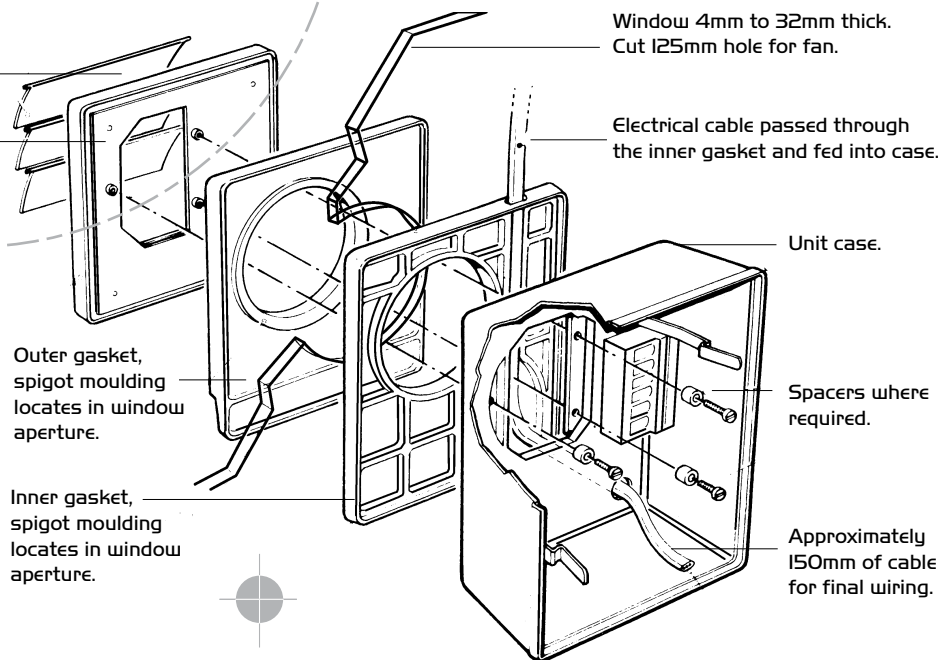
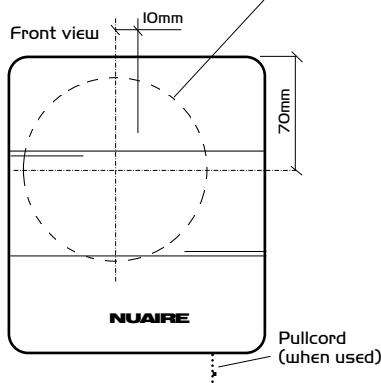

1. Employ a qualified glazier to cut a hole 125mm dia in the glass or, alternatively, replace your window with new glass incorporating a pre-cut hole (Fig. 8).

2. The outer assembly consists of a four bladed outlet shutter complete with clamping plate and an outer rubber gasket moulding. The gasket incorporates a moulded spigot which is designed to locate inside the 125mm dia hole in the glass.

Pop-out the top three plastic shutter blades from the frame and retain for replacement later. Position the assembly on the outside of the glass. If only one person is installing the fan it may be helpful to tape the assembly to the outside glass at this stage during installation as all fixings and assembly are completed from inside.

3. Working from inside the room with the inner gasket and unit casing. Run suitable cable through the inner gasket (Holes are provided top and bottom). Feed the cable through the access hole in the back of the case. Allow approximately 150mm of cable to protrude into the case. (See Fig.8). Position this inner gasket and case assembly over the hole in the glass and locate the inner gasket moulded spigot in the aperture.

4. Select appropriate screws and spacers from the four sets of screws and three spacers supplied for mounting into different thicknesses of glass, see table below.

Table 1 Glass/Screw selection

Window thickness	Screw size
4mm - 6mm	M4 x 12
7mm - 11mm	M4 x 20
12mm - 16mm	M4 x 30 + spacer
17mm - 21mm	M4 x 30
22mm - 26mm	M4 x 40 + spacer
27mm - 32mm	M4 x 40

Should the screws foul on the back of the shutters during installation replace with the next size down.

5. Using the three screws (and spacers fitting under the screw heads if required) locating with the threaded inserts in the outer assembly, draw the inner and outer assemblies together. Remove any tape supporting the outer assembly and continue to draw the units together until the rubber gaskets positively locate the unit on the window.

Note: do not overtighten the fixing screws as this may distort the assembly. Replace the shutters in the outer frame assembly.

6. Wire unit in accordance with the appropriate wiring diagram. A cable clamp is provided inside the case.

Note: the remaining installation procedures for Window Mounting are as Surface Mounting description.

Run-on timer and humidity set point

Figure 10.

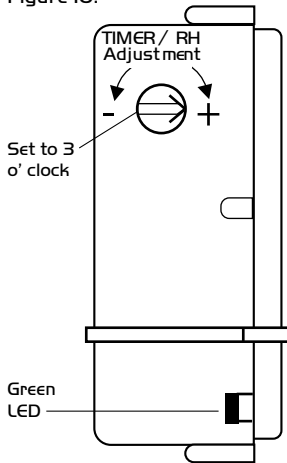

Run-on timer

When installing a unit with run-on timer the adjuster should initially be turned fully anti-clockwise. (This equates to a run-on of approximately 5 minutes).

Isolate unit from supply and remove front cover. Locate the electronic control module situated to the right of the fan/motor assembly.

Using a small screwdriver, turn the adjuster to the fully anti-clockwise position. Adjustment to the timer can subsequently be made to suit individual preferences.

Turn timer clockwise to increase run on time - maximum run on time is 30 mins.

Genie humidistat set up instructions

Set humidistat to mid position (3 o'clock) when viewed as figure 10 (approximately 60% RH).

Switch mains power ON (note, switched live e.g. light switch, should be off and the pull cord should not be pulled).

Under normal conditions the fan should be OFF. If the fan is ON and the green LED is on, turn adjustment clockwise until the light goes out.

Note the green light is ON when humidity is being sensed or the switched live/pullcord is activated. If the fan is running and the green light is OFF the fan is in its run-on period.

Coding

230V unit	12V unit	
GENIE		ON/OFF control, operated by pull cord or alternatively by remote switch*
GENIE PIR		ON/OFF control, via PIR. 230V only
GENIE - S	GENIE - S12	With integral run-on timer, operated by remote switch* only.
GENIE - H	GENIE - H12	With integral humidistat, operated by pull cord or remote switch*
GENIE - X	GENIE - X12	Continuous low duty with boost facility operated by pull cord or remote switch*
GENIE - XH	GENIE - XH12	Continuous low duty with boost facility via internal humidistat operated by pull cord or remote switch*

* light switch or similar

Note: Genie units are supplied with a finishing frame for use in semi-recessed applications.

WINKIT Optional window mounting kit. *Remote switch by others.

Power Consumption	230V	12V
Unit input power (watts)	23	28
Full load current (amps)	0.170	3.5
Starting Current (amps)	0.215	4.4

IMPORTANT

12V fan units must be installed in accordance with these instructions and IEE Wiring Regulations BS7671 for SELV installations.

Wiring details

IMPORTANT

Isolation - Before commencing work make sure the unit is electrically isolated from the mains and switched live supply. Means for double pole disconnection must be incorporated in the fixed wiring in accordance with the wiring regulations.

230V units via Remote Switch

- GENIE
- GENIE - S
- GENIE - H
- GENIE - X
- GENIE - XH

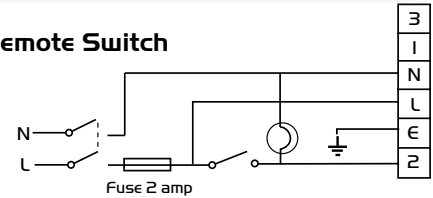

The switched Live signal to terminal 2 must be at 230V to enable the fan and at 0V to stop the fan after the adjustable timed overrun period. Induced voltages in the switched live field wiring can keep the unit running.

230V units via Pullcord

- GENIE
- GENIE - H
- GENIE - X
- GENIE - XH

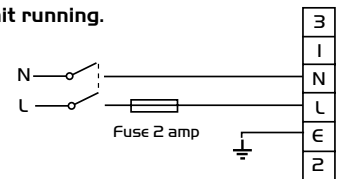

230V units via PIR

- GENIE PIR

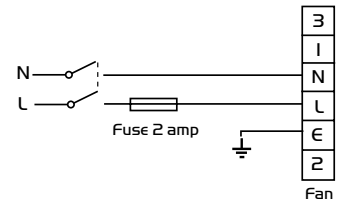

12V units via Pullcord

- GENIE - X12
- GENIE - H12
- GENIE - XH12

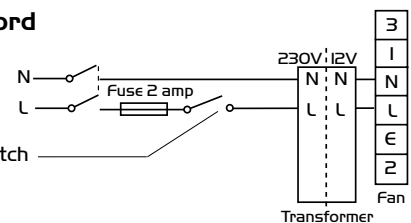

As wiring for remote switch above, excluding switch.

12V units via Remote Switch

- GENIE - S12
- GENIE - X12
- GENIE - H12
- GENIE - XH12

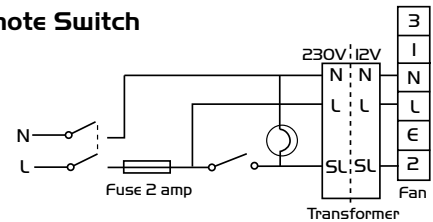

Transformer input power

Input power (watts)	35.0
Full load current (amps)	0.24
Starting Current (amps)	0.35

Installation notes for wiring sizes

It is important to note that the size of wire used between the transformer and the fan unit can have an adverse effect on the units performance if the following table is not adhered to.

Mains Supply: (230V) 0.5mm sq.

Transformer to fan

Cable run (max. 10 metres)	Cable size
Up to 2m	0.75mm sq.
Up to 4m	1.00mm sq.
Up to 6m	1.50mm sq.
Up to 10m	2.50mm sq.

Isolation - Before commencing work make sure that the unit is electrically isolated from the mains and switched live supply.

Installation of Transformer Enclosure (12 Volt units only)

The enclosure containing the transformer is intended to be mounted out of sight (e.g. in a loft, cupboard, under floorboards etc.). However, if this is not possible the transformer enclosure should be mounted as close to the ceiling, or as far from the "splash zone" as possible (see below for definition of the splash zone). As can be seen from the table of wiring sizes, it is advisable to place the enclosure as close to the fan as possible to reduce the costs of wiring and assist in installation.

'Splash zone'

The 'Splash Zone' can be considered to be an area within a bathroom or shower room where a person using the bath or shower can effectively reach. An arms reach is defined as 0.6 metres from the edge of the bath or shower up to a height of 2.25 metres.

Procedure

1. Remove two screws securing the cover and remove the cover.
2. Position the base enclosure on mounting surface and route cables through knockouts. Mark the fixing points on the mounting surface and secure using suitable fixings (by others).
3. Connect wiring as shown.
4. Replace cover.

Keep vents clear of obstruction.

Note: No earth is to be connected between transformer and fan.

Figure II. 12V Transformer details.

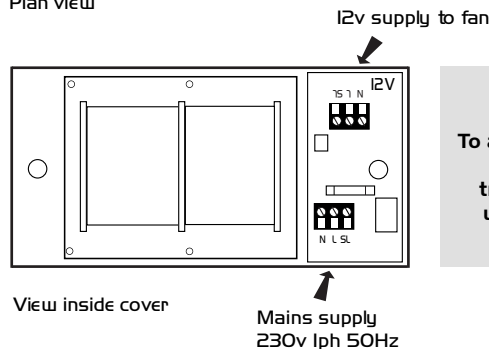
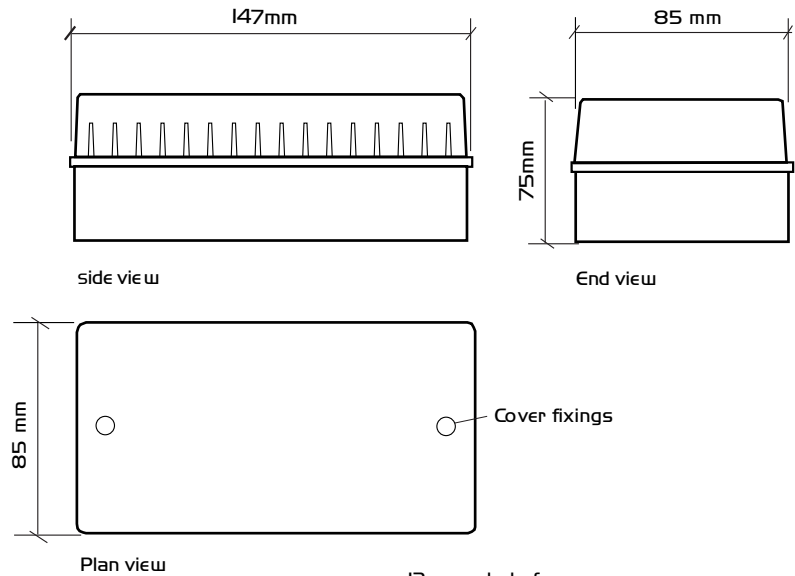

Note to installing electrician:
To avoid cable insulation contact with hot transformer, always use the knockout at PCB end.

IMPORTANT

12V fan units must be installed in accordance with these instructions and IEE Wiring Regulations BS7671 for SELV installations.

Maintenance

General

A washable filter is fitted to protect the fan/motor assembly from towel lint, talc etc. and to prolong the life of the unit. However, some fine dust may find its way through the filter and could build up on the motor and/or impeller. It is therefore strongly recommended that all units are inspected and cleaned at least every six months.

Procedure

At all times take care not to damage, distort or disturb the balance of the impeller. Remove the filter and the electronic control module. Spring aside the two clips and remove the fan module. Inspect and replace any damaged items.

Using a soft brush or dry cloth remove dust and dirt from the fan module. Wash front cover in warm soapy water and dry thoroughly. Re-fit fan and electronic control module, replace front cover and secure with screws. Wash filter on tepid water to which a little mild detergent has been added. Shake out excess water and allow to dry naturally. Replace filter. Refit the retaining screws (Fig 3). Test run the unit.

Replacement of Parts

Should any component need replacing Nuair keep extensive stocks for quick delivery. Ensure that the unit is electrically isolated, before carrying out any work.

When ordering spare parts, please quote the serial number of the unit and the ARC number of the purchase if possible.

(This information will be available on the fan label).

Warranty

The 5 year warranty starts from the day of delivery and includes parts and labour for the first year.

The remaining period covers replacement parts only. This warranty is conditional on planned maintenance being undertaken.

Service Enquiries

Nuair can assist you in all aspects of service. Our service department will be happy to provide any assistance required, initially by telephone and if necessary arrange for an engineer to call.

**Customer Services Department
on 08705 002 555**

Technical or commercial considerations may, from time to time, make it necessary to alter the design, performance and dimensions of equipment and the right is reserved to make such changes without prior notice.