

ESH Ecosmart Heaters Installation Guide

ecosmart
energy saving control

ESH Ecosmart Heater

The Ecosmart Heater should only be used as a supplementary heater in conjunction with a Ecosmart supply fan with integral electric heater. It must not be used with any other fans.

The heater is a 3kW single phase unit that requires an independent 230V mains supply to the top mounted terminal box and is supplied with a pre-plugged 10m length of communications cable.

This heater will provide additional heat where the desired temperature cannot be achieved by the supply fan's integral heater alone.

Note: the air velocity through the heater section must be 1.5m/s or greater.

Installing the Heater

The Heater must be fitted indoors, away from any water spray or source of steam.

The heater is installed into the ductwork (by others) using the fast clamps at the downstream side of the supply fan.. Larger, heavier units should be adequately supported.

Figure 1. ESH Ecosmart heater typical system application.

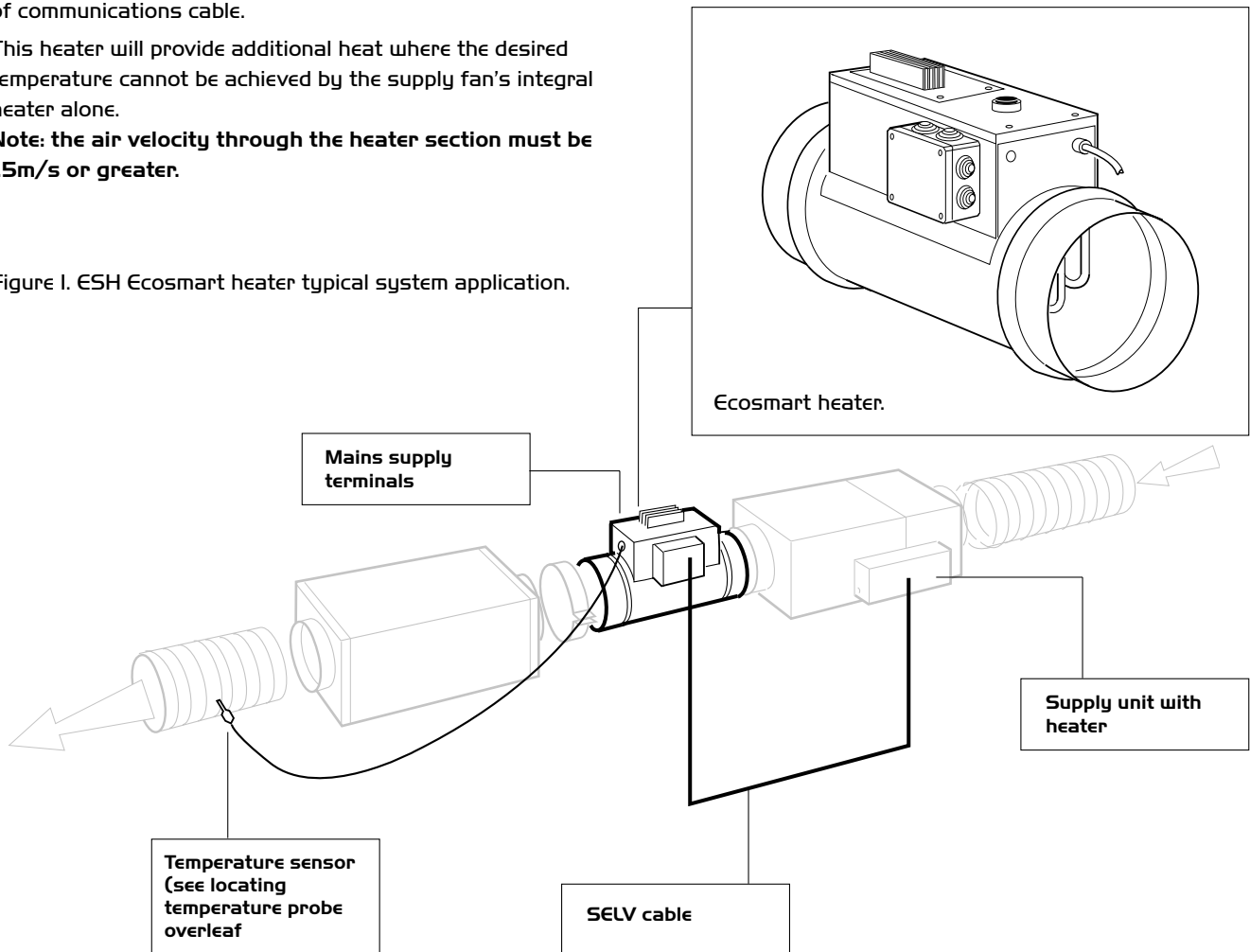

NuAire Limited Western Industrial Estate Caerphilly United Kingdom CF83 1NA
Telephone: 029 2088 5911 Facsimile: 029 2088 7033
Email: info@nuaire.co.uk www.nuaire.co.uk

Leaflet Number 671181 January 2003

Wiring in the heater

The heater requires two connections; the SELV communications cable link up and the 230V mains L,N,E connection to power the heater element. Remove the top cover from the terminal box by rotating the four fixing screws half a turn. The communications cable (supplied) can now be plugged into the socket marked Ecosmart NET inside the box. (See fig 2). The other end of the SELV cable should be plugged into the connection box of the associated supply fan in the system.

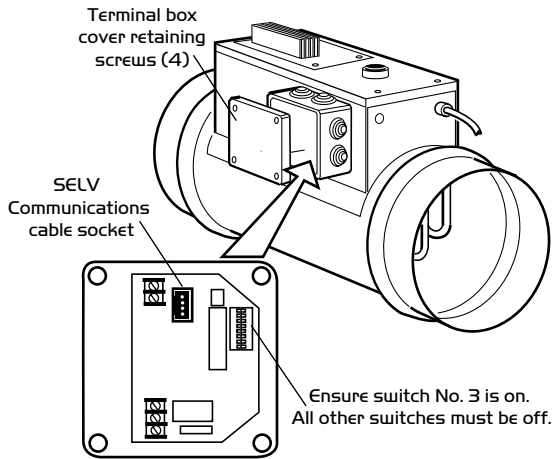

Figure 2. SELV cable connection on heater.

Data Cable installation

A 4-core SELV data cable is used to connect devices. Do not run data cable in the same conduit as the mains cables and ensure there is a 50mm separation between the data cable and other cables. The maximum cable run between any two devices is 300m when it is installed in accordance with the instructions. Please note that the total data cable length used in any system must be less than 1000m. Keep the number of cable joints to a minimum to ensure the best data transmission efficiency between devices.

To connect the mains supply to the unit it is necessary to remove the casing from the heater body. Remove the two fixing screws and lift off the casing to reveal the terminal block marked LNE (See fig 3). Knockouts are provided in the casing panel for cable entry. Connect mains wiring to terminals (3kW 230V a.c. 1 phase).

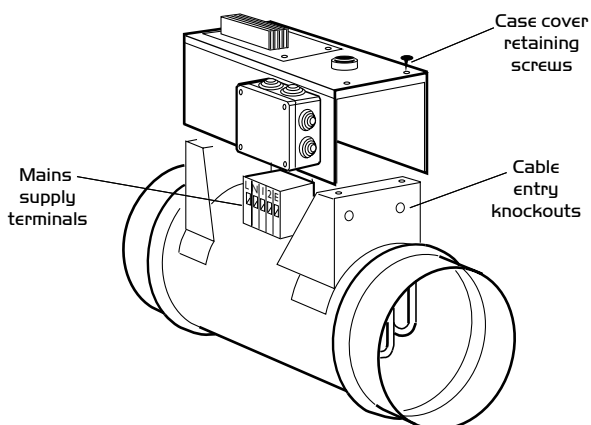

Figure 3. Connecting the mains supply.

Locating the temperature probe sensor

A flying lead is attached to the heater module which is terminated with a temperature sensing probe. The probe should be located in the ductwork approximately 500mm DOWNSTREAM of the heater. (See fig 1)

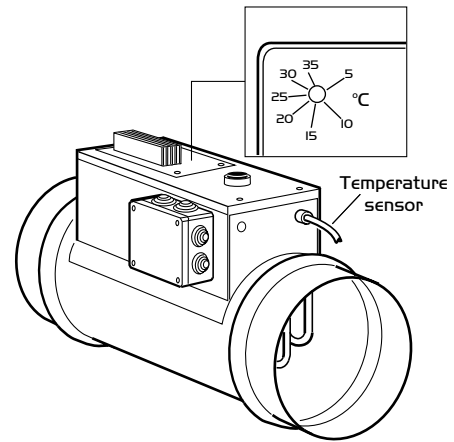

Figure 4. Setting the 'air off' temperature.

Setting the 'air-off' temperature

A variable 'air off' temperature adjustment is provided on the side of the heater module (see fig 4). The setting is adjustable from 5 - 35°C and is achieved by inserting a small screwdriver into the adjuster aperture and rotating the spindle clockwise or anti-clockwise.

Manual Reset button

The heater will normally operate automatically. To ensure safe operation it has a safety cut-out with a manual reset button, located on the top of the casing (see fig 5). This may be used to reactivate the heater in the event of a shut down due to overheating.

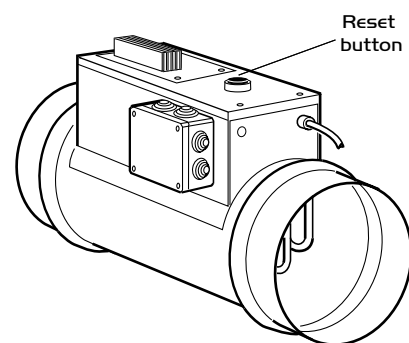
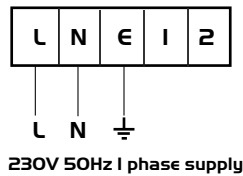

Figure 5. Manual reset button.

Wiring

Mains wiring



SELV data link

Ecosmart heater

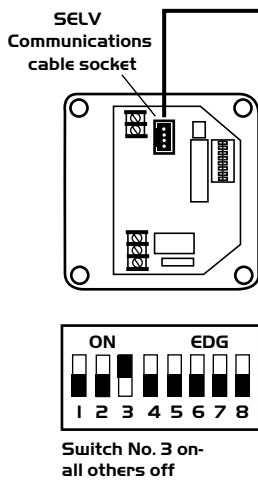

Ecosmart Scurbo with heater

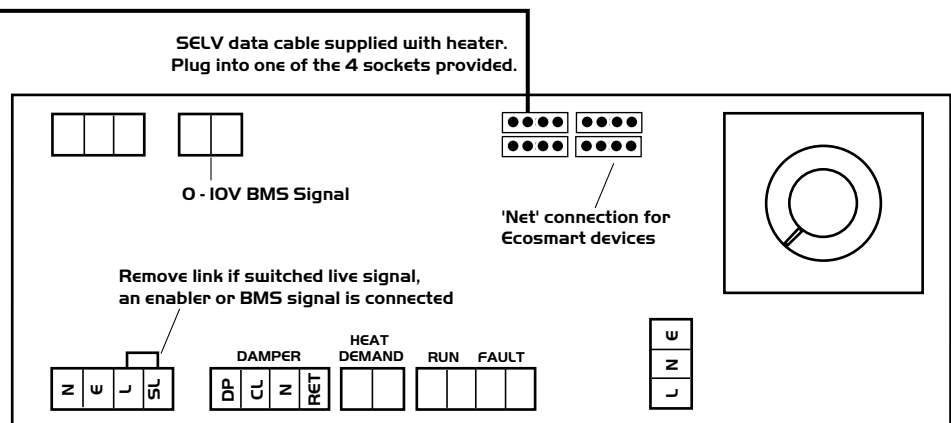

Replacement of Parts

Should any component need replacing Nuair keep extensive stocks for quick delivery. Ensure that the unit is electrically isolated, before carrying out any work.

When ordering spare parts, please quote the serial number of the unit and the ARC number of the purchase if possible.

(This information will be available on the fan label).

3 Year Warranty

The 3 year warranty starts from the day of delivery and includes parts and labour for the first year.

The remaining 2 years covers replacement parts only.

This warranty is conditional on planned maintenance being undertaken.

Service Enquiries

Nuair can assist you in all aspects of service. Our service department will be happy to provide any assistance required, initially by telephone and If necessary arrange for an engineer to call.

Telephone 029 2085 8585



Fax 029 2085 8586

DECLARATION OF INCORPORATION AND INFORMATION FOR SAFE INSTALLATION, OPERATION AND MAINTENANCE

We declare that the machinery named below is intended to be assembled with other components to constitute a system of machinery. The machinery shall not be put into service until the system has been declared to be in conformity with the provisions of the EC Council Machinery Directive.

Designation of machinery: ECOSMART HEATER
 Machinery Types: ESH
 Relevant EC Council Directives: 98/37/EC (Machinery Directive)
 Applied Harmonised Standards: EN292-1, EN292-2, EN294, EN29001
 Applied National Standards: BS848 Parts One, Two and Five

Signature of manufacture representatives:



Name:	Position:	Date:
1) C. Biggs 	Technical Director	23. 12. 02
2) W. Glover 	Manufacturing Director	23. 12. 02

CE DECLARATION OF CONFORMITY

We declare that the machine named below conforms to the requirements of EC Council Directives relating to Electromagnetic Compatibility and Safety of Electrical Equipment.

Designation of machinery: ECOSMART HEATER
 Machinery Types: ESH
 Relevant EC Council Directives: 89/336/EEC, 92/31/EEC (EMC)
 73/23/EEC, 93/68/EEC (Low Voltage Directive)
 Applied Harmonised Standards: EN55014-1, EN55014-2, EN60204-1
 EN60335-2-80
 Basis of Self Attestation: Quality Assurance to BS EN ISO 9001
 BSI Registered Firm Certificate
 No. FM 149

Signature of manufacture representatives:

Name:	Position:	Date:
1) C. Biggs 	Technical Director	23. 12. 02
2) W. Glover 	Manufacturing Director	23. 12. 02

INFORMATION FOR SAFE INSTALLATION, OPERATION AND MAINTENANCE OF NUAIRE VENTILATION EQUIPMENT

To comply with EC Council Directives 98/37/EC Machinery Directive

To be read in conjunction with the relevant Product Documentation (see 2.1)

1.0 GENERAL

- 1.1 The equipment referred to in this Declaration of Incorporation is supplied by NuAire to be assembled into a ventilation system which may or may not include additional components.
 The entire system must be considered for safety purposes and it is the responsibility of the installer to ensure that all of the equipment is installed in compliance with the manufacturers recommendations and with due regard to current legislation and codes of practice.

2.0 INFORMATION SUPPLIED WITH THE EQUIPMENT

- 2.1 Each item of equipment is supplied with a set of documentation which provides the information required for the safe installation and maintenance of the equipment. This may be in the form of a Data sheet and/or Installation and Maintenance instruction.
 2.2 Each unit has a rating plate attached to its outer casing. The rating plate provides essential data relating to the equipment such as serial number, unit code and electrical data. Any further data that may be required will be found in the documentation. If any item is unclear or more information is required, contact NuAire.
 2.3 Where warning labels or notices are attached to the unit the instructions given must be adhered to.

3.0 TRANSPORTATION, HANDLING AND STORAGE

- 3.1 Care must be taken at all times to prevent damage to the equipment. Note that shock to the unit may result in the balance of the impeller being affected.
 3.2 When handling the equipment, care should be taken with corners and edges and that the weight distribution within the unit is considered. Lifting gear such as slings or ropes must be arranged so as not to bear on the casing.
 3.3 Equipment stored on site prior to installation should be protected from the weather and steps taken to prevent ingress of contaminants.

4.0 OPERATIONAL LIMITS

- 4.1 It is important that the specified operational limits for the equipment are adhered to e.g. operational air temperature, air borne contaminants and unit orientation.
 4.2 Where installation accessories are supplied with the specified equipment eg. wall mounting brackets. They are to be used to support the equipment only. Other system components must have separate provision for support.
 4.3 Flanges and connection spigots are provided for the purpose of joining to ductwork systems. They must not be used to support the ductwork.

5.0 INSTALLATION REQUIREMENTS

In addition to the particular requirements given for the individual product, the following general requirements should be noted.

- 5.1 Where access to any part of equipment which moves, or can become electrically live are not prevented by the equipment panels or by fixed installation detail (eg ducting), then guarding to the appropriate standard must be fitted.
 5.2 The electrical installation of the equipment must comply with the requirements of the relevant local electrical safety regulations.

6.0 COMMISSIONING REQUIREMENTS

- 6.1 General pre-commissioning checks relevant to safe operation consist of the following:
 Ensure that no foreign bodies are present within the fan or casing
 Check electrical safety. e.g. Insulation and earthing.
 Check guarding of system.
 Check operation of Isolators/Controls.
 Check fastenings for security.
 6.2 Other commissioning requirements are given in the relevant product documentation.

7.0 OPERATIONAL REQUIREMENTS

- 7.1 Equipment access panels must be in place at all times during operation of the unit, and must be secured with the original fastenings.
 7.2 If failure of the equipment occurs or is suspected then it should be taken out of service until a competent person can effect repair or examination. (Note that certain ranges of equipment are designed to detect and compensate for fan failure).

8.0 MAINTENANCE REQUIREMENTS

- 8.1 Specific maintenance requirements are given in the relevant product documentation.
 8.2 It is important that the correct tools are used for the various tasks required.
 8.3 If the access panels are to be removed for any reason the electrical supply to the unit must be isolated.
 8.4 A minimum period of two minutes should be allowed after electrical disconnection before access panels are removed. This will allow the impeller to come to rest.
NB: Care should still be taken however since airflow generated at some other point in the system can cause the impeller to "windmill" even when power is not present.
 8.5 Care should be taken when removing and storing access panels in windy conditions.