

Sqrbo In-line Centrifugal Fan Installation and Maintenance

Sqrbo Fans

The Sqrbo range of in-line centrifugal fans consists of 6 duty sizes with a maximum of 0.4 m³/s.

Units are manufactured from galvanised steel to B.S. 2989 1982, are rectangular in section and have circular rigid spigots at each end. All units are supplied with a unique mounting bracket designed to simplify installation.

Handling

Always handle the units carefully to avoid damage and distortion. Care must be taken to ensure that any slings used for hoisting do not damage the casing.

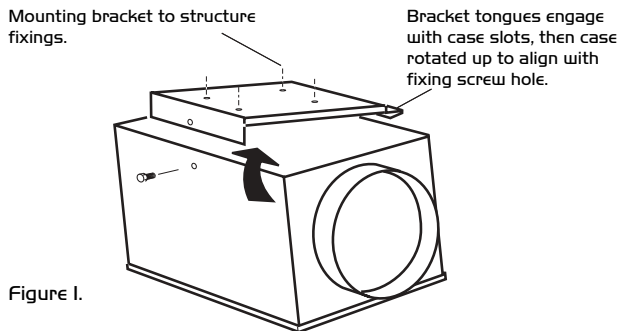

Figure 1.

Fan Installation

Installation must be completed by competent persons, in accordance with good industry practice and should conform to all governing and statutory bodies i.e. IEE, CIBSE, COHSE etc.

The fan must be fitted indoors, on a secured surface, away from sources of water spray or steam generation. The fan can be installed using the integral mounting bracket which enables the unit to be installed at any angle and be retained by a single set-screw.

Figure 2. Reversing the direction of flow.

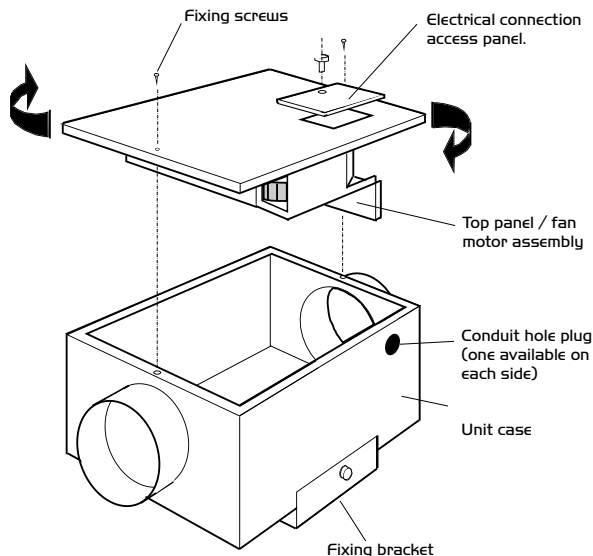

After the mounting bracket is fixed to a secure surface ensure the two projecting lugs (on bracket) engage in the slots in the unit casing, then secure using the fixing screw supplied (Figure 1).

The Fan/motor assembly can be withdrawn from its casing and turned through 180° to change the air flow direction. This can be carried out after the unit has been installed allowing unit/silencer combination option to have a position change of the silencer from upstream (as supplied) to downstream (See Figure 2).

Electrical

Remove the small panel on main cover of the unit for access (See Figure 2). Electrical supply can be via the conduit access holes provided in the casing.

Wiring Details

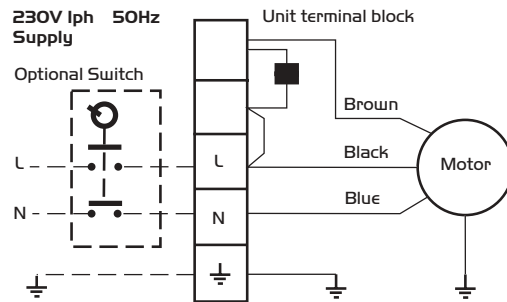

Check the fan voltage and circuit details are compatible with the power supply. Wiring must comply with appropriate regulations including any requirements of the local supply authority.

Fuses should be regarded as protection against short circuits only and not protection against overload. **Fuses must withstand starting loads, (3 times running current for 10 seconds).**

Motor Details

Unit Code	Input power (Watts)	Start Current (amps)	F.l.c (amps)	Nominal Fan Speed (r.p.m.)	Max. permissible air temp passing over motor. °C
S 1 - 100	43	0.474	0.32	2724	50 *
S 2 - 125	43	0.474	0.32	2724	50 *
S 3 - 150	75	0.466	0.34	2285	50 *
S 4 - 200	150	1.49	0.72	2544	50 *
S 5 - 250	170	1.54	0.92	2313	50 *
S 6 - 315	170	1.54	0.92	2313	50 *

* 40° C when speed control is used.

Maintenance

Electrically isolate before commencing work. Remove covers and carefully clean out interiors as necessary. Check for damage and security of components. Refit covers.

The motor bearings do not require lubrication as they are maintenance free 'sealed for life' type.

3 Year Warranty

The 3 year warranty starts from the day of delivery and includes parts and labour for the first year, and replacement parts only for 2 years. This warranty is conditional on planned maintenance, the first at 3 months, thereafter at 12 months. These intervals may be less if the unit operates in adverse conditions.





Nuaire Limited Western Industrial Estate Caerphilly United Kingdom CF83 1NA
Telephone: 029 2088 5911 Facsimile: 029 2088 7033
Email: info@nuaire.co.uk www.nuaire.co.uk

DECLARATION OF INCORPORATION AND INFORMATION FOR SAFE INSTALLATION, OPERATION AND MAINTENANCE

We declare that the machinery named below is intended to be assembled with other components to constitute a system of machinery. The machinery shall not be put into service until the system has been declared to be in conformity with the provisions of the EC Council Machinery Directive.

Designation of machinery: SQRUBO
Machinery Types: SI-100, S2I25, S3-150, S4-200, S5-250, S6-315
Relevant EC Council Directives: 98/37/EC (Machinery Directive)
Applied Harmonised Standards: EN292-1, EN292-2, EN294, EN29001
Applied National Standards: BS848 Parts One, Two and Five

Signature of manufacture representatives:



Name:	Position:	Date:
1) C. Biggs 	Technical Director	23. 12. 02
2) W. Glover 	Manufacturing Director	23. 12. 02

CE DECLARATION OF CONFORMITY

We declare that the machine named below conforms to the requirements of EC Council Directives relating to Electromagnetic Compatibility and Safety of Electrical Equipment.

Designation of machinery: SQRUBO
Machinery Types: SI-100, S2I25, S3-150, S4-200, S5-250, S6-315
Relevant EC Council Directives: 89/336/EEC, 92/31/EEC (EMC)
 73/23/EEC, 93/68/EEC (Low Voltage Directive)
Applied Harmonised Standards: EN5501, EN61000 - 6 - 2, EN60204-1
Basis of Self Attestation: Quality Assurance to BS EN ISO 9001
 BSI Registered Firm Certificate
 No. FM 149

Signature of manufacture representatives:

Name:	Position:	Date:
1) C. Biggs 	Technical Director	23. 12. 02
2) W. Glover 	Manufacturing Director	23. 12. 02

INFORMATION FOR SAFE INSTALLATION, OPERATION AND MAINTENANCE OF NUAIRE VENTILATION EQUIPMENT

To comply with EC Council Directives 98/37/EC Machinery Directive

To be read in conjunction with the relevant Product Documentation (see 2.1)

1.0 GENERAL

- 1.1 The equipment referred to in this Declaration of Incorporation is supplied by NuAire to be assembled into a ventilation system which may or may not include additional components.
 The entire system must be considered for safety purposes and it is the responsibility of the installer to ensure that all of the equipment is installed in compliance with the manufacturers recommendations and with due regard to current legislation and codes of practice.

2.0 INFORMATION SUPPLIED WITH THE EQUIPMENT

- 2.1 Each item of equipment is supplied with a set of documentation which provides the information required for the safe installation and maintenance of the equipment. This may be in the form of a Data sheet and/or Installation and Maintenance instruction.
- 2.2 Each unit has a rating plate attached to its outer casing. The rating plate provides essential data relating to the equipment such as serial number, unit code and electrical data. Any further data that may be required will be found in the documentation. If any item is unclear or more information is required, contact NuAire.
- 2.3 Where warning labels or notices are attached to the unit the instructions given must be adhered to.

3.0 TRANSPORTATION, HANDLING AND STORAGE

- 3.1 Care must be taken at all times to prevent damage to the equipment. Note that shock to the unit may result in the balance of the impeller being affected.
- 3.2 When handling the equipment, care should be taken with corners and edges and that the weight distribution within the unit is considered. Lifting gear such as slings or ropes must be arranged so as not to bear on the casing.
- 3.3 Equipment stored on site prior to installation should be protected from the weather and steps taken to prevent ingress of contaminants.

4.0 OPERATIONAL LIMITS

- 4.1 It is important that the specified operational limits for the equipment are adhered to e.g. operational air temperature, air borne contaminants and unit orientation.
- 4.2 Where installation accessories are supplied with the specified equipment eg. wall mounting brackets. They are to be used to support the equipment only. Other system components must have separate provision for support.
- 4.3 Flanges and connection spigots are provided for the purpose of joining to ductwork systems. They must not be used to support the ductwork.

5.0 INSTALLATION REQUIREMENTS

In addition to the particular requirements given for the individual product, the following general requirements should be noted.

- 5.1 Where access to any part of equipment which moves, or can become electrically live are not prevented by the equipment panels or by fixed installation detail (eg ducting), then guarding to the appropriate standard must be fitted.
- 5.2 The electrical installation of the equipment must comply with the requirements of the relevant local electrical safety regulations.

6.0 COMMISSIONING REQUIREMENTS

- 6.1 General pre-commissioning checks relevant to safe operation consist of the following:
 Ensure that no foreign bodies are present within the fan or casing
 Check electrical safety. e.g. Insulation and earthing.
 Check guarding of system.
 Check operation of Isolators/Controls.
 Check fastenings for security.
- 6.2 Other commissioning requirements are given in the relevant product documentation.

7.0 OPERATIONAL REQUIREMENTS

- 7.1 Equipment access panels must be in place at all times during operation of the unit, and must be secured with the original fastenings.
- 7.2 If failure of the equipment occurs or is suspected then it should be taken out of service until a competent person can effect repair or examination. (Note that certain ranges of equipment are designed to detect and compensate for fan failure).

8.0 MAINTENANCE REQUIREMENTS

- 8.1 Specific maintenance requirements are given in the relevant product documentation.
- 8.2 It is important that the correct tools are used for the various tasks required.
- 8.3 If the access panels are to be removed for any reason the electrical supply to the unit must be isolated.
- 8.4 A minimum period of two minutes should be allowed after electrical disconnection before access panels are removed. This will allow the impeller to come to rest.
NB: Care should still be taken however since airflow generated at some other point in the system can cause the impeller to "windmill" even when power is not present.
- 8.5 Care should be taken when removing and storing access panels in windy conditions.

Technical or commercial considerations may, from time to time, make it necessary to alter the design, performance and dimensions of equipment and the right is reserved to make such changes without prior notice.