



XTRACTOR - 3 phase Belt Drive Roof & Plantroom Single Fans Installation and Maintenance Manual

ESX

ESX-X

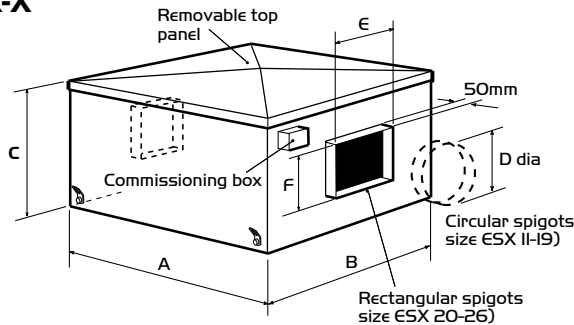

Fig. 1 ESX*-X Plantroom/Roof mounted in line unit.

Unit	A	B	C	D dia	E	F
ESX II-X to ESX I2-X	974	974	622	400	-	-
ESX I3-X to ESX I4-X	1233	1233	701	500	-	-
ESX I5-X to ESX I9-X	1430	1190	796	630	-	-
ESX 20-X to ESX 26-X	2030	1466	1183	-	1200	700

ESX-R

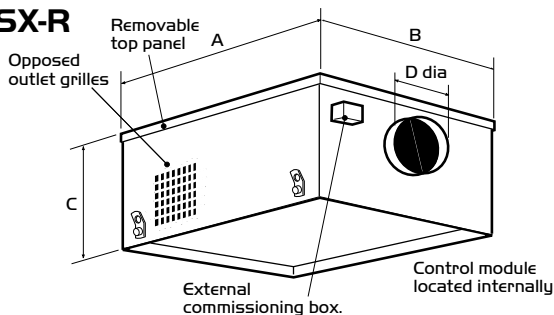

Fig. 2 ESX*-R roof mounted end inlet, side discharge unit.

Unit	A	B	C	D dia
ESX II-R to ESX I2-R	974	974	622	400
ESX I3-R to ESX I4-R	1233	1233	701	500
ESX I5-R to ESX I9-R	1430	1190	796	630

Introduction

The Nuairé ESX Belt Drive range consists of the following units:

ESX-X (Duct Mounted, Plantroom/Roof) in line unit

ESX-R (Roof Mounted, end inlet) side discharge unit*

ESX-B (Roof Mounted bottom inlet) side discharge unit*

* larger size units have end discharge.

Units are rectangular in section. The casing is manufactured from heavy gauge 'Aluzinc' aluminium-zinc coated mild steel. A full size internally lined access panel is fitted to the top face and this panel is fully detachable for inspection purposes.

The motor plate and frames are supported on the base by resilient mountings allowing the fan unit to be operated without the need for separate anti vibration fan case

mountings. The units incorporate an independent motor with high efficiency, forward curved centrifugal impeller running in a metal scroll. Taper locked pulleys and wedge drive belts are employed. The motor is manufactured to BS5000 and suitable for three phase supply.

Airflow and failure monitors are standard as is Class F insulation. Suitable for operation in ambient temperatures up to 40°C.

Handling

Handle the units carefully to avoid damage and distortion. Eyebolts are provided on some units for lifting purposes. If mechanical aids are used to lift the unit, spreaders should be employed and positioned so as to prevent the slings, webbing etc. making contact with the casing.

ESX-B

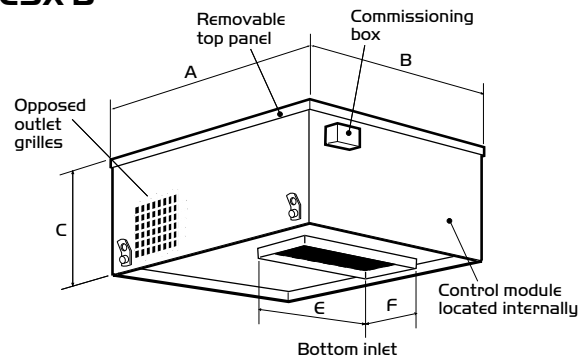

Fig. 3 Bottom inlet units

Unit	A	B	C	E	F
ESX II-B to ESX I2-B	974	974	622	457	229
ESX I3-B to ESX I4-B	1233	1233	701	762	304
ESX I5-B to ESX I9-B	1430	1190	796	889	381

ESX-B/R Larger units

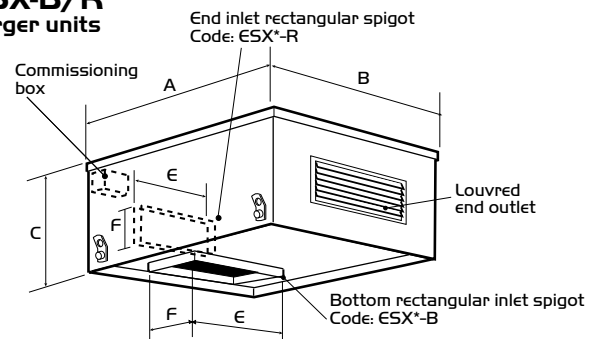

Fig. 4 Bottom / End inlet units. Large sizes

Unit	A	B	C	E	F
ESX 20-B to ESX 26-B	2030	1466	1183	1200	700
ESX 20-R to ESX 26-R	2030	1466	1183	1200	700

Installation

Installation must be carried out by competent personnel in accordance with the appropriate authority and conforming to all statutory and governing regulations.

Units must not be installed at an angle over 5° from the horizontal (to ensure the backdraught shutters operate satisfactorily).

Units should always be positioned with sufficient space to allow removal of the access covers and subsequent removal of fan and motor assemblies etc.

Ductwork connections must be airtight to prevent loss of performance.

The method of mounting used is the total responsibility of the installer. The lower edge of the casing has an internal skirt allowing the unit to be located on an upstand or prefabricated curb if desired. The units must be securely screw fixed to the upstand/curb to prevent vibration and/or wind damage.

It is the installers responsibility to drill the case to provide access for the electrical cables. Care should be taken not to damage internal components and the cable entry must be properly sealed. NOTE: on bottom inlet units the electrical cabling may be routed up through the bottom inlet spigot.

Testing after installation

Ensure that the Fan unit and any specified controls are fitted securely according to the instructions.

Switch on the mains supply. Push the test button to run each fan and check that they run satisfactorily.

If a switched live signal is used, activate this signal and check that the fan runs. De-activate the switched live signal and check the run-on-time; adjust if necessary.

Adjust the set point of any sensors and PIR; check that they function correctly.

Adjust the maximum and minimum airflow (if required) by following the commissioning procedures.

Roof Opening Dimensions

Fig. 5

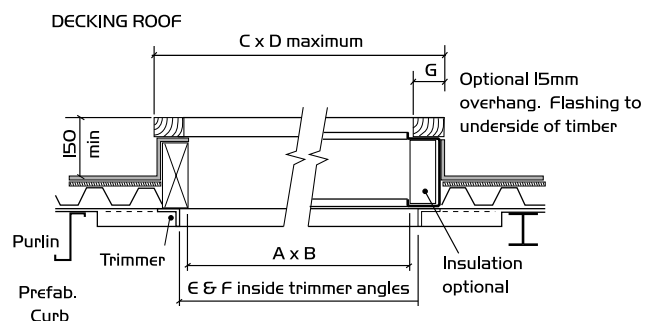
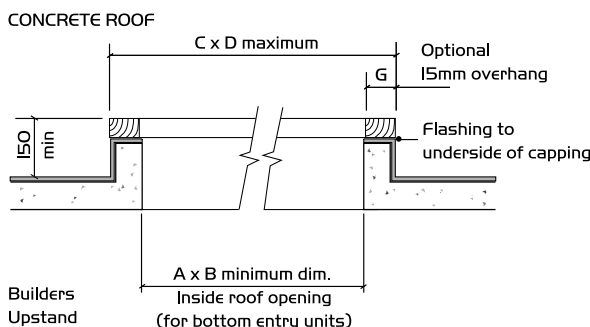

Table 6. Dimensions (mm)

Unit Code	Prefab Code	A	B	C	D	E	F	G
ESX 11-12	ESPFC 4B	767	767	947	947	837	837	75
ESX 13-14	ESPFC 5B	973	973	1203	1203	1064	1064	100
ESX 15-19	ESPFC 6B5	1174	936	1404	1166	1265	1027	100

Note: Prefabricated curbs can be used to support internal or external units.

Prefabricated Curb

CODES: ESP* (typical)

Manufactured in pre galvanised steel these curbs will reduce design work and guarantee correct unit mounting when on site.

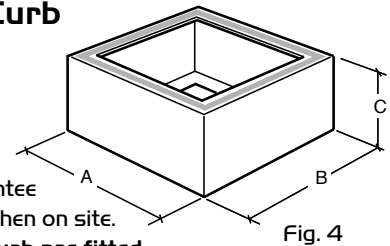

Note: Upper faces of curb are fitted with robust sealing strip.

Table 5. Prefabricated curb dimensions

Unit Code	Prefab Curb Code	A	B	C
ESX 11-12	ESPFC 4B	917	917	250
ESX 13-14	ESPFC 5B	1173	1173	250
ESX 15-19	ESPFC 6B5	1374	1136	250

Upstand Details

Details of roof opening dimensions etc required and basic construction of a builders upstand etc are shown below for typical concrete and decking roof installations.

Typical roof upstand requirements

Fig. 7 Roof upstand details

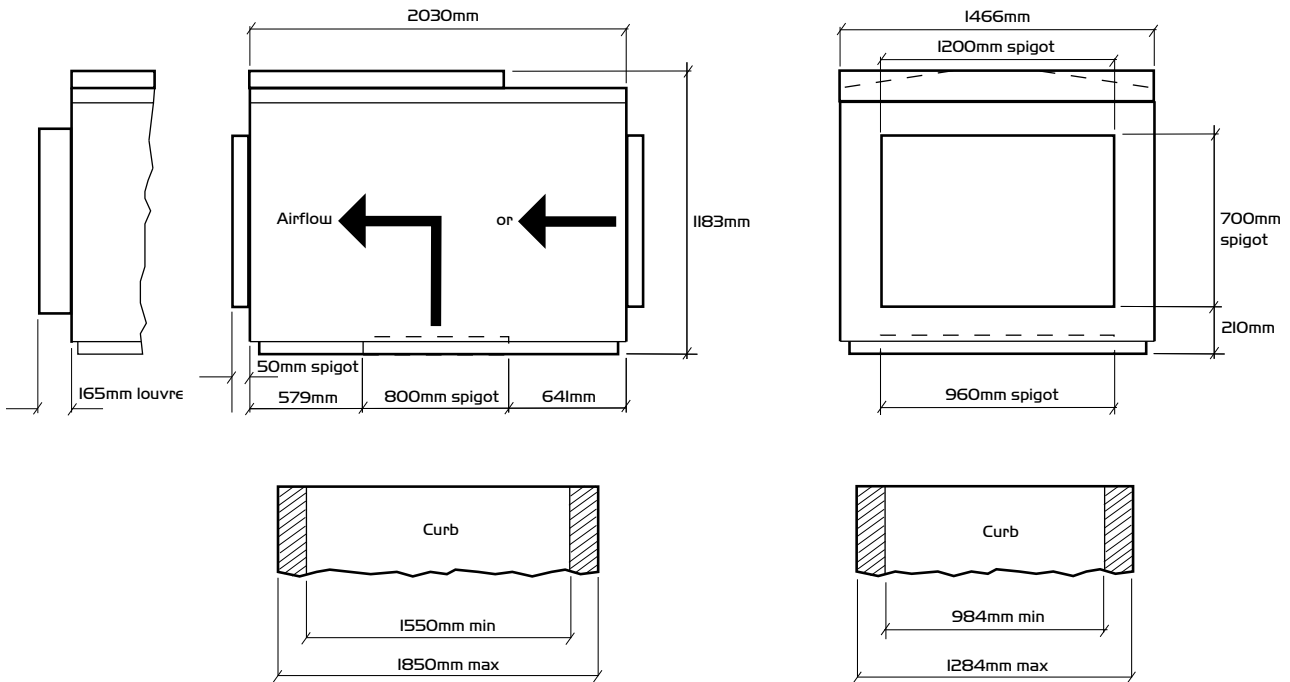

Electrical Details

Isolation - Before commencing work make sure that the unit, switched live and Nuaire control are electrically isolated from the mains supply.

Warning - Inverter Speed Control
 An Inverter is used to provide speed control. When the fan is isolated, allow 5 minutes for the capacitors in the inverter to discharge before commencing any work on the unit.

RDC

If a RDC is fitted to protect the circuit, a type B RCD should be used (trip limit 300mA). Otherwise nuisance tripping will occur.

Because the run and start currents depend upon the duty and associated ductwork of an individual unit, the values quoted in the table are nominal.

Run currents will be exceeded if the unit is operated with its cover removed. It is therefore recommended that the unit is not run for prolonged periods in this condition.

Table 7. Run currents etc.

Unit Code*	400V 3 Phase 50Hz			Weight kg
	Speed rpm	Power (kW)	f Ic* (amps)	
ESX 11 - *	1225	0.75	2.1	62
ESX 12 - *	1400	1.1	2.9	64
ESX 13 - *	1085	1.5	3.7	90
ESX 14 - *	1225	2.2	5.4	94
ESX 15 - *	1040	2.2	5.4	135
ESX 16 - *	1040	4.0	10.0	143
ESX 17 - *	1260	3.0	6.9	139
ESX 18 - *	1260	5.5	12.0	158
ESX 19 - *	1440	5.5	12.0	158
ESX 20 - *	700	5.5	12.0	730
ESX 21 - *	800	4.0	10.0	716
ESX 22 - *	800	11.0	23.0	794
ESX 23 - *	1000	5.5	12.0	730
ESX 24 - *	1000	11.0	23.0	794
ESX 25 - *	1100	11.0	23.0	794
ESX 26 - *	1200	11.0	23.0	794

* Start current not applicable as Ecosmart twinfans feature 'soft start'

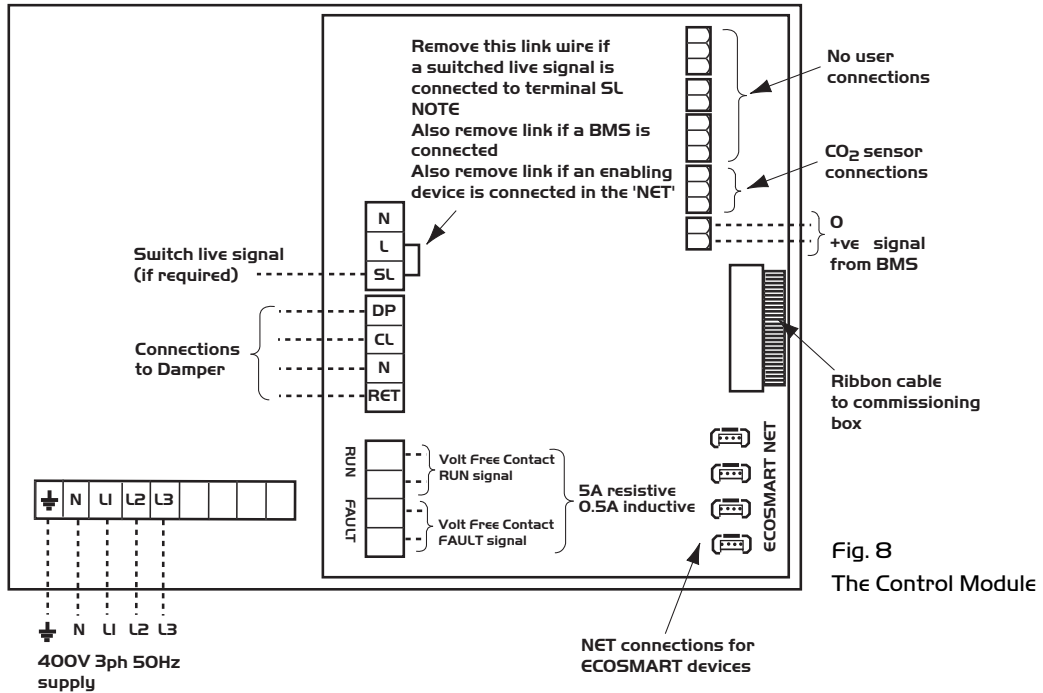

Fig. 8
The Control Module

Important: This product must be earthed.

Warning - Inverter Speed Control

An Inverter is used to provide speed control. When the fan is isolated, allow 5 minutes for the capacitors in the inverter to discharge before commencing any work on the unit.

Connections (see fig 9).

a) Control Connections

Net - the 4 IDC plug-in connectors are provided for the connection of compatible sensors, manual controls and for linking the fans together under a common control. If more than 4 connections are required, the junction box (product code ES-JB) should be used. (See Data Cable Installation).

Switch Live (SL) terminal - A signal of 100-230V a.c. will activate the fan. Note that a signal from an isolating transformer will produce an unpredictable result and is not recommended.

b) Damper connections

- OP** - 230V 50Hz IA max supply to open the damper
- CL** - 230V 50Hz IA max supply to close the damper
- N** - Neutral supply to damper
- RET** - 230V ac return signal from the damper limit switch to indicate the damper has reached its operating position. If the return signal is not present, the fan will wait for 1 minute before starting.

c) Volt Free Relay Contacts

Note that the volt free contacts are not fused. If these are used to power any external equipment, the installer must provide adequate fusing or other protections. These contacts are rated at 5A resistive, 0.5A inductive.

Run connections - These contacts are closed when the fan is running.

Fault connections - No fault = the contacts are closed.

Fault = the contacts are opened (this includes no power supply at the unit).

d) Data Cable installation

A 4-core SELV data cable is used to connect devices such as sensors to the fan and for interconnecting multiple fan units.

Do not run data cable in the same conduit as the mains cables and ensure there is a 50mm separation between the data cable and other cables. The maximum cable run between any two devices is 300m when it is installed in accordance with the instructions.

Please note that the total data cable length used in any system must be less than 1000m. Keep the number of cable joints to a minimum to ensure the best data transmission efficiency between devices.

e) Maximum number of devices

The maximum number of devices (including fans) that can be connected together via the cable is 32, irrespective of their functions.

f) Any other low voltage/signal cable connection i.e. BMS

Follow the guidelines as given in 'd' and keep the cable length as short as possible - less than 50m.

Using the Test button

The test button allows the fan/blower to be checked for operation. If the fan is running, pressing the button once will stop it, pressing a second time, or if the fan was not running, will restart it. **The fan will return to normal operation after 30 seconds.**

Connections (continued)

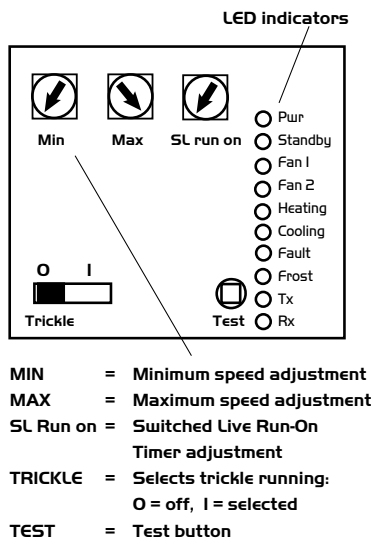

Fig. 9 Commissioning panel details.

Warning - Inverter Speed Control
 An Inverter is used to provide speed control. When the fan is isolated, allow 5 minutes for the capacitors in the inverter to discharge before commencing any work on the unit.

LED Indication

- PWR** GREEN: Power on & OK,
- Standby** LED on when fan is not running.
- Fan 1** GREEN: Fan 1 is running, RED: Fan 1 faulty.
- Fan 2** GREEN: Fan 2 is running, RED: Fan 2 faulty.
- Heating*** Not applicable. See note.
- Cooling*** Not applicable. See note.
- Fault** LED on when a fault is present on unit.
- Frost*** Not applicable. See note.
- Tx** LED on when the controller is transmitting data.
- Rx** LED on when the controller is receiving data.

* Note that the control panel is common to all the Ecosmart products and will have indicators for functions that are not available in this particular fan. However these indicators will not be illuminated.

BMS input signals

The fan's response to a 0-10V dc BMS signal is given in the following table. Note the BMS signal will override any sensors and user control connected in the system. The voltage tolerance is +/- 125mV and is measured at the fans terminal.

	Ventilation mode	Cooling Mode*	Heating Mode*
Local control	0.00	-	-
OFF / trickle	0.25	-	-
Speed 1	0.50	0.75	1.00
Speed 2	1.50	1.75	2.00
Speed 3	2.50	2.75	3.00
Speed 4	3.50	3.75	4.00
Speed 5	4.50	4.75	5.00
Speed 6	5.50	5.75	6.00
Speed 7	6.50	6.75	7.00
Speed 8	7.50	7.75	8.00
Speed 9	8.50	8.75	9.00
Speed 10	9.50	9.75	10.00

* Only available on relevant unit

Getting started

The Ecosmart Xtract fan is designed for maximum control flexibility. Apart from the power supply, an enabling signal is **always** required to set the fan running.

This enabling signal can be a switched live signal (connected to the SL terminal of each fan) or an enabling device plugged in the NET connection.

If an enabling signal is not available, connect a link wire from 'L' to 'SL'.

Additional sensor and manual control may be added.

For example: to run the fan with a temperature sensor, connect a link across L to SL (enabling signal) and connect a temperature sensor in one of the sockets labelled 'NET'. The fan will now adjust it's speed according to temperature.

To obtain manual control, connect a link across L to SL (enabling signal) and connect a user control in one of the sockets labelled 'NET'.

Settings

Setting the Maximum air flow

- i) Ensure the power supply is switched off and that a link wire is connected from the supply L to the SL terminal. Unplug all items connected to the 'Net' connectors.
- ii) Switch on the power supply.

NOTE: Ensure unit top cover is securely attached.

- iii) Wait for the fan to complete its self-test operation.
- iv) Remove the cover of the units external commissioning box.

Measure the airflow using standard commissioning instruments at a suitable point in the ductwork. If adjustment is required, rotate the pot marked 'MAX' to obtain the desired airflow.

Setting the minimum trickle airflow (nominal 40%)

- i) Repeat the same procedure as for maximum airflow above but without the link wire between supply L and SL terminal. Ensure the trickle switch is in the 'ON' position. The adjustment must be made on the pot marked 'Min'.
- ii) Note that the minimum setting (nominally 40%) must be below the maximum setting, otherwise minimum setting will be automatically set to be the same as the maximum.

Maintenance - Fan unit

Maintenance Intervals

The first maintenance should be carried out three months after commissioning and thereafter at twelve monthly intervals. These intervals may need to be shortened if the unit is operating in adverse environmental conditions, or in heavily polluted air. Access to the unit internals is gained by removing the top cover(s).

Motors

Brush away any dust or dirt from the motor housings and ensure that the motor vents are unblocked. (cont on page 6).

Maintenance cont.

Isolation - Before commencing work make sure that the unit, switched live and NuAire control are electrically isolated from the mains supply.

Warning - Inverter Speed Control

An Inverter is used to provide speed control. When the fan is isolated, allow 5 minutes for the capacitors in the inverter to discharge before commencing any work on the unit.

Bearings

Lubrication is unnecessary as the motors are fitted with sealed for life bearings.

Impellers

Remove any dust and check that the impellers are securely fixed to the motor shafts. Take care not to disturb any balance weights fitted. Check sealed for life bearings for excessive wear.

Anti Vibration motor plate mountings

The motor plate is supported on ten individual resilient mountings. Check that mountings are secure and in good condition.

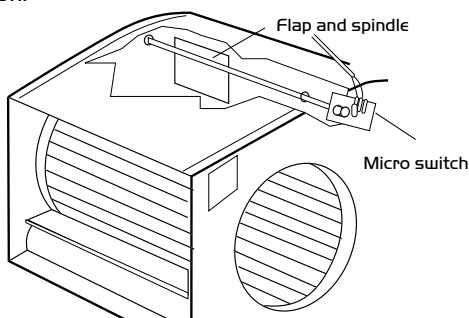

Fig. 10

Aiflow Flapswitch for Auto Changeover (if fitted) Fig. 10

Check the flag switches operate freely by locating the spindle and flap (through the blower outlet aperture) and carefully moving the flap. A click will be heard when the switch operates. **NOTE: Do not bend the flaps.**

Adjusting Drive Belt tension (ESX II-I9)

To check the correct tension of a drive belt, apply a force at right angles to the centre of the belt span sufficient to deflect the belt 16mm for every metre of span length (see fig. II). The force required to deflect the 'V' belt should be from 0.5kg to 0.8kg. The tension of the belt should be checked after 24hrs of continuous running and adjusted as necessary.

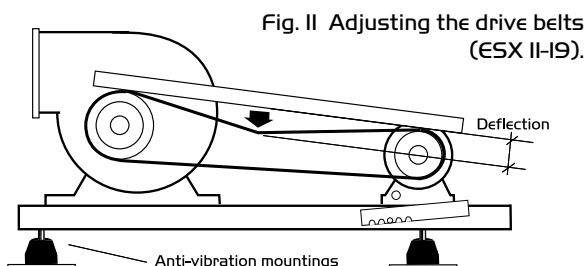

Fig. II Adjusting the drive belts (ESX II-I9).

Changing a Drive Belt

To replace a belt, remove the two bolts from the motor mounting furthest from the fan and slacken the remaining two bolts. Lift the motor plate and remove the belt. Replacing the belt is the reverse of this procedure.

Adjusting Drive Belt tension (ESX 20-26)

All belt drive units incorporate belt tensioning devices. To adjust the belt tension, slacken the pinch bolt on the sides of the motor plate. Turn the adjusting bolt clockwise to tighten the belt and counter clockwise to loosen it. The drive should be tensioned until a slight bow appears in the slack side of the 'V' belt when running under load.

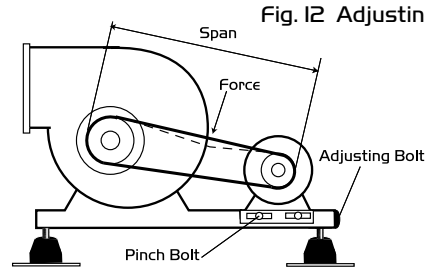

Fig. I2 Adjusting the drive belts (ESX 20-26).

To check for correct tension, proceed as follows:

1. Measure the span length (See fig. I2).
2. At the centre of the span, apply a force at right angles to the belt sufficient to deflect one belt 16mm for every metre of span length (see fig. I2). The force required to deflect the 'V' belt should be from 0.5kg to 0.8kg.
3. Tighten the pinch bolts.

General Cleaning and Inspection

Clean and inspect the exterior of the fan unit and associated controls etc. Remove the access panel from the fan unit. Inspect and, if necessary, clean the fan and motor assemblies and the interior of the case. If the unit is heavily soiled it may be more convenient to remove the fan / motor assemblies. If NuAire controls and or remote indicators are fitted, remove the covers and carefully clean out the interiors as necessary. Check for damage. Check security of components. Refit the access covers.

General

1. Check that all fixings are tight.
2. Check sealing strips around the fan outlets are tight up against the bulkhead.
3. Check that duct connections are not leaking.

Warranty

Xtractor has a 3 year warranty. Ecosmart Xtractor has a 5 year warranty. The warranty starts from the day of delivery and includes parts and labour for the first year. The remaining period covers replacement parts only. This warranty is conditional on planned maintenance being undertaken.

Service Enquiries

NuAire can assist you in all aspects of service. Our service department will be happy to provide any assistance required, initially by telephone and If necessary arrange for an engineer to call within 48 hours if possible.

Telephone 029 2085 8585
Fax 029 2085 8586



Technical or commercial considerations may, from time to time, make it necessary to alter the design, performance and dimensions of equipment and the right is reserved to make such changes without prior notice.

DECLARATION OF INCORPORATION AND INFORMATION FOR SAFE INSTALLATION, OPERATION AND MAINTENANCE

We declare that the machinery named below is intended to be assembled with other components to constitute a system of machinery. The machinery shall not be put into service until the system has been declared to be in conformity with the provisions of the EC Machinery Directive.

Designation of machinery: Ecosmart Belt Drive Single Fan Xtractor
Machinery Types: ESX
Relevant EC Council Directives: 98/37/EC as amended by 98/79/EC (Machinery Directive)
Applied Harmonised Standards: BS EN ISO 12100-1, BS EN ISO 12100-2, EN294, EN60204-1, BS EN ISO 9001
Applied National Standards: BS848 Parts One, Two and Five

Signature of manufacture representatives:

Name:	Position:	Date:
1) C. Biggs	 Technical Director	20. 07. 07
2) W. Glover	 Manufacturing Director	20. 07. 07

INFORMATION FOR SAFE INSTALLATION, OPERATION AND MAINTENANCE OF NUAIRE VENTILATION EQUIPMENT

To comply with EC Council Directives 98/37/EC Machinery Directive and 2004/108/EC (EMC).

To be read in conjunction with the relevant Product Documentation (see 2.1)

1.0 GENERAL

- 1.1 The equipment referred to in this Declaration of Incorporation is supplied by Nuairé to be assembled into a ventilation system which may or may not include additional components.
 The entire system must be considered for safety purposes and it is the responsibility of the installer to ensure that all of the equipment is installed in compliance with the manufacturer's recommendations and with due regard to current legislation and codes of practice.

2.0 INFORMATION SUPPLIED WITH THE EQUIPMENT

- 2.1 Each item of equipment is supplied with a set of documentation which provides the information required for the safe installation and maintenance of the equipment. This may be in the form of a Data sheet and/or Installation and Maintenance instruction.
 2.2 Each unit has a rating plate attached to its outer casing. The rating plate provides essential data relating to the equipment such as serial number, unit code and electrical data. Any further data that may be required will be found in the documentation. If any item is unclear or more information is required, contact Nuairé.
 2.3 Where warning labels or notices are attached to the unit the instructions given must be adhered to.

3.0 TRANSPORTATION, HANDLING AND STORAGE

- 3.1 Care must be taken at all times to prevent damage to the equipment. Note that shock to the unit may result in the balance of the impeller being affected.
 3.2 When handling the equipment, care should be taken with corners and edges and that the weight distribution within the unit is considered. Lifting gear such as slings or ropes must be arranged so as not to bear on the casing.
 3.3 Equipment stored on site prior to installation should be protected from the weather and steps taken to prevent ingress of contaminants.

4.0 OPERATIONAL LIMITS

- 4.1 It is important that the specified operational limits for the equipment are adhered to e.g. operational air temperature, air borne contaminants and unit orientation.
 4.2 Where installation accessories are supplied with the specified equipment eg. wall mounting brackets. They are to be used to support the equipment only. Other system components must have separate provision for support.
 4.3 Flanges and connection spigots are provided for the purpose of joining to duct work systems. They must not be used to support the ductwork.

5.0 INSTALLATION REQUIREMENTS

In addition to the particular requirements given for the individual product, the following general requirements should be noted.

- 5.1 Where access to any part of equipment which moves, or can become electrically live are not prevented by the equipment panels or by fixed installation detail (eg ducting), then guarding to the appropriate standard must be fitted.
 5.2 The electrical installation of the equipment must comply with the requirements of the relevant local electrical safety regulations.
 5.3 For EMC all control and sensor cables should not be placed within 50mm or on the same metal cable tray as 230V switched live, lighting or power cables and any cables not intended for use with this product.

6.0 COMMISSIONING REQUIREMENTS

- 6.1 General pre-commissioning checks relevant to safe operation consist of the following:
 Ensure that no foreign bodies are present within the fan or casing.
 Check electrical safety. e.g. Insulation and earthing.
 Check guarding of system.
 Check operation of Isolators/Controls.
 Check fastenings for security.
 6.2 Other commissioning requirements are given in the relevant product documentation.

7.0 OPERATIONAL REQUIREMENTS

- 7.1 Equipment access panels must be in place at all times during operation of the unit, and must be secured with the original fastenings.
 7.2 If failure of the equipment occurs or is suspected then it should be taken out of service until a competent person can effect repair or examination. (Note that certain ranges of equipment are designed to detect and compensate for fan failure).

8.0 MAINTENANCE REQUIREMENTS

- 8.1 Specific maintenance requirements are given in the relevant product documentation.
 8.2 It is important that the correct tools are used for the various tasks required.
 8.3 If the access panels are to be removed for any reason the electrical supply to the unit must be isolated.
 8.4 A minimum period of two minutes should be allowed after electrical disconnection before access panels are removed. This will allow the impeller to come to rest.
NB: Care should still be taken however since airflow generated at some other point in the system can cause the impeller to "windmill" even when power is not present.
 8.5 Care should be taken when removing and storing access panels in windy conditions.



Nuaire Group
Western Industrial Estate
Caerphilly United Kingdom
CF83 INA
T: 029 2088 5911
F: 029 2088 7033
E: info@nuaire.co.uk
W: www.nuaire.co.uk