

Constant Pressure, Single phase, Direct Drive Single & Twinfan Units For external use only

Installation and Maintenance

Models
ESTCP & ESXCP

ESTCP-X & ESXCP-X

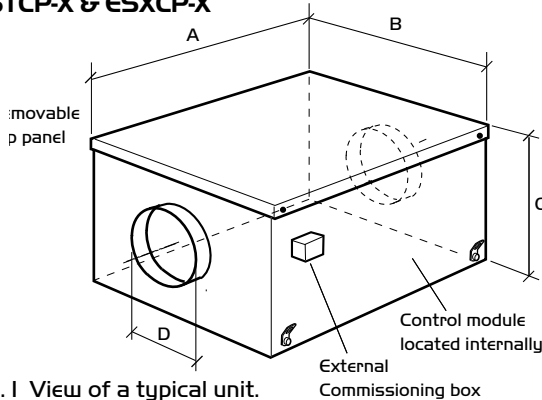

Fig. 1 View of a typical unit.

Unit	A	B	C	D dia.	Weight (kg)	
					EST	ESX
ESTCP4-X	1165	980	575	250	85	-
ESTCP6-X/ESXCP6-X	1165	980	575	400	86	70
ESTCP9-X/ESXCP9-X	1495	1125	710	500	162	133

ESTCP-R & ESXCP-R, ESTCP-B, & ESXCP-B

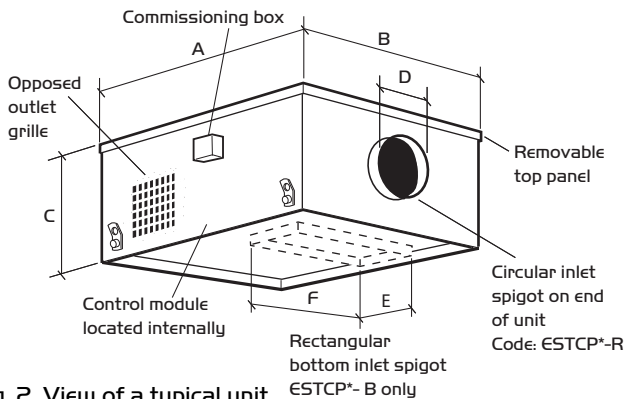

Fig. 2 View of a typical unit.

Unit	A	B	C	D dia.	E	F	Weight (kg)	
							EST	ESX
ESTCP4-R	1165	980	575	250	-	-	85	-
ESTCP4-B	1165	980	575	-	152	305	85	-
ESTCP6-R/ESXCP6-R	1165	980	575	400	-	-	86	70
ESTCP6-B/ESXCP6-B	1165	980	575	-	229	457	86	70
ESTCP9-R/ESXCP9-R	1495	1125	710	500	-	-	162	133
ESTCP9-B/ESXCP9-B	1495	1125	710	-	304	762	162	133

Introduction

The Nuair range of constant pressure direct drive external units consists of single and twinfan models with duties up to a maximum of 1.5m³/s. Twinfan units incorporate run/standby and auto changeover features whereas the single fan units have one fan only. Coding is as follows:

ESTCP-X and ESXCP-X are 'in-line' units supplied with rigid circular spigots at each end and are **suited to external and internal duct mounted applications.**

ESTCP-R and ESXCP-R are supplied with rigid circular inlet spigot and two opposed side discharge spigots, **suited to external roof mounted applications.**

ESTCP-B and ESXCP-B are supplied with rigid circular inlet spigot and two opposed side discharge spigots, **suited to external roof mounted applications.**

Casings are manufactured from heavy gauge 'Aluzinc' aluminium and zinc coated mild steel. Full size access panels are fitted to the top of the units. These panels are fully detachable for inspection and connection purposes. The units incorporate two independent motors with high efficiency, centrifugal impellers running in metal scrolls.

The motors are manufactured to BS 5000 and are suitable for single phase supply. Airflow and failure monitors are standard as is Class B insulation. The units are suitable for operation in ambient temperatures up to 40°C.

Handling

Handle the units carefully to avoid damage and distortion. If mechanical aids are used to lift the unit, spreaders should be employed and positioned so as to prevent the slings, webbing etc. making contact with the casing.

Installation

The installation must be carried out by competent personnel in accordance with the appropriate authority and conforming to all statutory and governing regulations.

The units are suitable for internal or external use. All units can be installed at any angle up to 60°. However, **on a sloping roof the unit must be blowing upwards** toward the roof ridge to ensure correct backdraught shutter operation.

Units should always be positioned with sufficient space to allow removal of the access cover and subsequent removal of fan and motor assemblies etc.

Whether internally or externally mounted, the method of fixing is the responsibility of the installer.

All units have a bottom skirt to allow for fixing directly onto a suitably sized curb or builders upstand. Nuair can supply a matching prefabricated curb for these units. Details of curbs and dimensions for a suitable external concrete upstand are shown on page 2. Ductwork connections must be airtight to prevent any loss of performance.

All units have an internal connection box requiring connection to the mains supply on installation. It is the installers responsibility to drill the case to provide access for the electrical cables. Care should be taken not to damage internal components and the cable entry should be properly sealed.

Installation (continued)

A commissioning box is provided on the outside of the case. The unit should be securely screwed to its curb or mounting to prevent vibration and/or wind damage. Note that on the bottom inlet (ESTCP-B/ESXCP-B) units, the cabling could be carried up from inside the building through the bottom inlet spigot.

Prefabricated Curb

CODES: ESPFC* (typical)

Manufactured in pre-galvanised steel these curbs will reduce design work and guarantee correct unit mounting when on site.

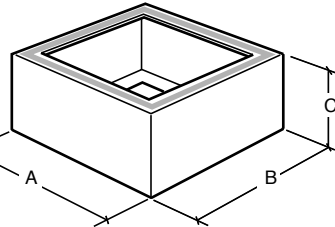

Fig. 3

Note: Upper faces of curb are fitted with robust sealing strip.

Table 3. Prefabricated curb dimensions.

Unit Code	Prefab Curb Code	A	B	C
ESTCP4*	ESPFC 4	1095	910	250
ESTCP6*/ESXCP6*	ESPFC 4	1095	910	250
ESTCP9*/ESXCP9*	ESPFC 5	1425	1045	250

Roof Opening and Curb Dimensions Fig. 4

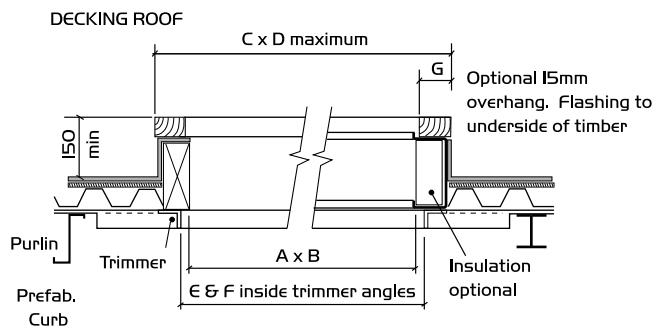
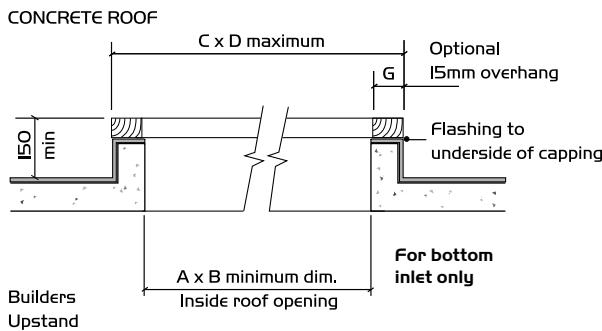
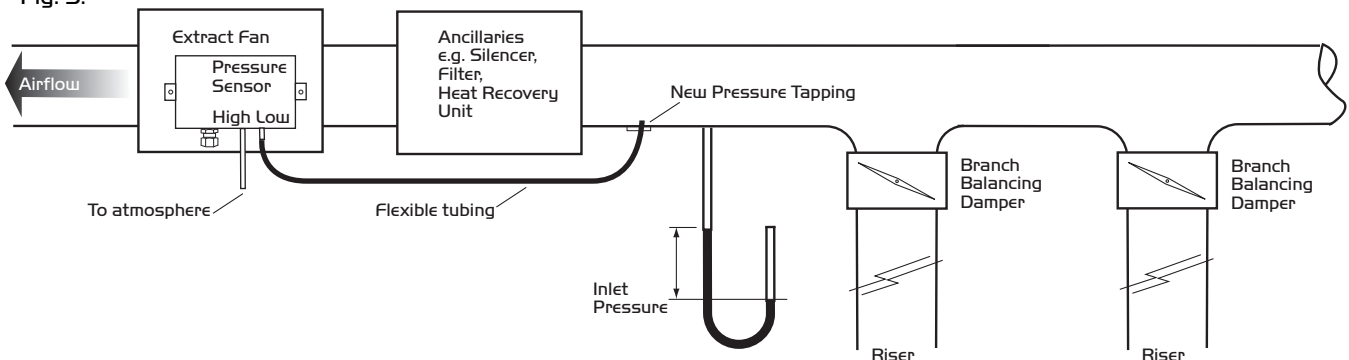

Table 4. Dimensions (mm)

Unit Code	A	B	C	D	E	F	G
ESTCP4*	940	760	1120	940	1105	920	75
ESTCP6*/ESXCP6*	940	760	1120	940	1105	920	75
ESTCP9*/ESXCP9*	1265	900	1445	1080	1435	1065	75

Controlling static pressure at fan inlet

Ecosmart constant pressure extract fans are supplied to control the static pressure at the fan inlet. This set up is suitable for the majority of applications. However, when ancillaries with high pressure losses are fitted to the fan's inlet side, the low pressure tapping needs to be moved from the fan chamber to a location upstream of the ancillaries as shown below in fig. 5. Failure to do this will result in excessive pressure being applied to the dampers at the rooms when the system is running in trickle mode.



Electrical Details

IMPORTANT

Isolation - Before commencing work make sure that the unit, switched live and Nuaire control are electrically isolated from the mains supply.

Warning - Inverter Speed Control

An inverter is used to provide speed control. When the fan is isolated, allow 5 minutes for the capacitors in the inverter to discharge before commencing any work on the unit.

RCD

If a RCD is fitted to protect the circuit, a type B RCD should be used (trip limit 300mA). Otherwise nuisance tripping will occur.

Wiring Connections

Fig. 6.

Control module connection details.

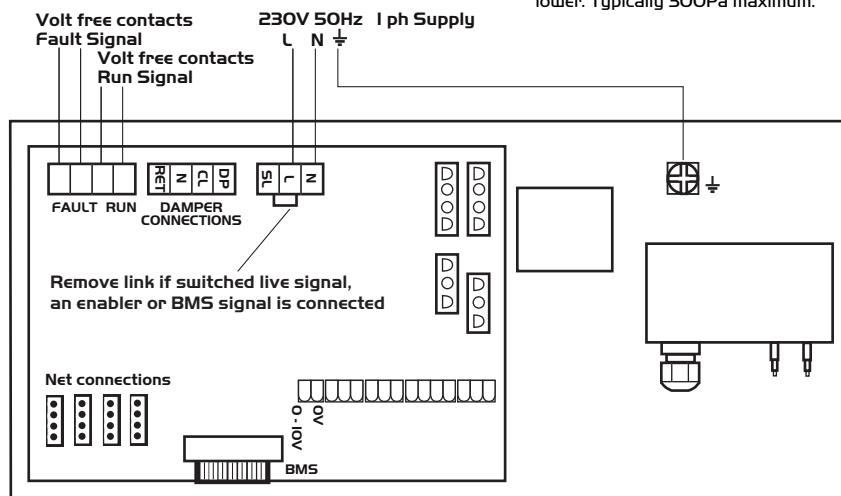

a) Control Connections (see fig. 6).

Net - the 4 IDC plug-in connectors are provided for the connection of compatible sensors, manual controls and for linking the fans together under a common control. If more than 4 connections are required, junction box (product code ES-JB) should be used. See 'd' Data Cable Installation.

Switch Live (SL) terminal - A signal of 100-230V a.c. will activate the fan.

Note that a signal from an isolating transformer will produce an unpredictable result and is not recommended.

b) Damper connections

OP - 230V 50Hz IA max supply to open the damper

CL - 230V 50Hz IA max supply to close the damper

N - Neutral supply to damper

RET - 230V ac return signal from the damper limit switch to indicate the damper has reached its operating position. If the return signal is not present, the fan will wait for 1 minute before starting.

Note: If a damper is not fitted, connect a link wire from OP to RET. This will cancel the delay.

c) Volt Free Relay Contacts

Note that the volt free contacts are not fused. If these are used to power any external equipment, the installer must provide adequate fusing or other protections.

These contacts are rated at 5A resistive, 0.5A inductive.

Because the run and start currents depend upon the duty and associated ductwork of an individual unit, the values quoted in the table are nominal.

Run currents will be exceeded if the unit is operated with its cover removed. It is therefore recommended that the unit is not run for prolonged periods in this condition.

Motor - Electrical Information

Table 5.

230V single phase 50Hz only

Unit Code	Max Speed rpm	Input Power (kW)	FLC* (A)	Fuse** rating (A)	Operating Pressure Min*** (Pa)	Operating Pressure Max*** (Pa)
ESTCP4	3600	0.52	3.1	5	50	450
ESTCP6/ESXCP6	1270	1.1	6	10	50	350
ESTCP9/ESXCP9	960	1.6	9	10	50	350

* Starting current not applicable as units feature 'soft start'.

** Recommended fuse rating of the circuit supplying the unit.

*** Operating pressure measured across the unit at maximum speed.

Actual controlled pressure (i.e. Constant Pressure setting) would be lower. Typically 300Pa maximum.

Please note this product must be earthed.

Run connections - These contacts are closed when the fan is running.

Fault connections - No fault = the contacts are closed. Fault = the contacts are opened (this includes no power supply at the unit).

d) Data Cable installation

A 4-core SELV data cable is used to connect devices such as sensors to the fan and for interconnecting multiple fan units.

Do not run data cable in the same conduit as the mains cables and ensure there is a 50mm separation between the data cable and other cables.

The maximum cable run between any two devices is 300m when it is installed in accordance with the instructions. Please note that the total data cable length used in any system must be less than 1000m. Keep the number of cable joints to a minimum to ensure the best data transmission efficiency between devices.

e) Maximum number of devices

The maximum number of devices (including fans) that can be connected together via the data cable is 32, irrespective of their functions.

f) Any other low voltage/signal cable connection i.e. BMS

Follow the guidelines as given in 'd' and keep the cable length as short as possible - less than 50m.

Connections (continued)

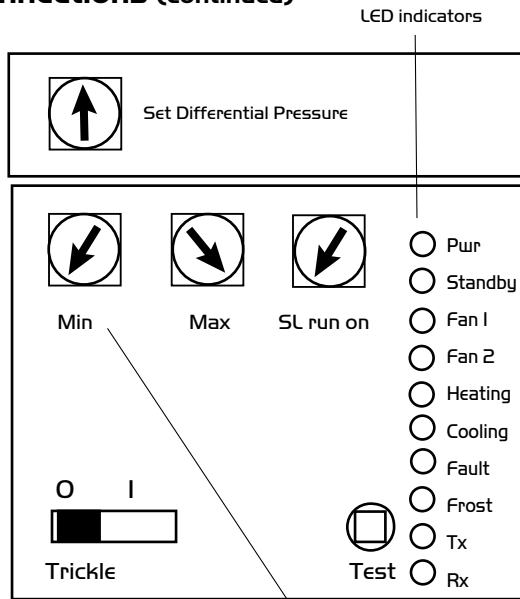

- MIN = Minimum speed adjustment
- MAX = Maximum speed adjustment
- SL Run on = Switched Live Run-On
Timer adjustment
- TRICKLE = Selects trickle running:
0 = off, I = selected
- TEST = Test button

Fig. 7. Commissioning panel details.

IMPORTANT

Warning - Inverter Speed Control

An Inverter is used to provide speed control. When the fan is isolated, allow 5 minutes for the capacitors in the inverter to discharge before commencing any work on the unit.

Using the Test button

The test button allows the individual blowers within the unit to be checked for its operation. If the fan is running already, press the button once to stop the fan, press again to switch on the standby fan, press again to stop and so on.

Note that the fan will return to normal operation after 30 seconds.

LED Indication

- PWR** GREEN: Power on & OK,
- Standby** LED on when fan is not running.
- Fan 1** GREEN: Fan 1 is running, RED: Fan 1 faulty.
- Fan 2** GREEN: Fan 2 is running, RED: Fan 2 faulty.
- Heating*** Not applicable. See note.
- Cooling*** Not applicable. See note.
- Fault** LED on when a fault is present on unit.
- Frost*** Not applicable. See note.
- Tx** LED on when the controller is transmitting data.
- Rx** LED on when the controller is receiving data.

* Note that the control panel is common to all the Ecosmart products and will have indicators for functions that are not available in this particular fan. However these indicators will not be illuminated.

BMS input signals

The fan's response to a 0-10V dc BMS signal is given in the following table. Note the BMS signal will override any sensors and user control connected in the system. The voltage tolerance is +/- 125mV and is measured at the fans terminal.

Ventilation mode	
Local control	0.00
OFF / trickle	0.25
0.50 or higher the fan operates	

Settings

Setting the Maximum fan speed

- i) This adjustment should only be made if running the fan at maximum speed would cause a problem on site.
- ii) Switch off the power supply, connect a link wire between L and SL.
Unplug all items connected to the 'Net' connections. Set the pressure setting to the maximum position.
- iii) Switch on the power supply, allow the fan to reach a steady speed (approx. 30 seconds). Adjust the pot marked 'Max' to set the maximum speed.
- iv) After setting the speed, switch off the power and reconnect the wiring.

Setting the Minimum fan speed

- i) This adjustment should only be made if running the fan at minimum speed would cause a problem on site.
- ii) Switch off the power supply, connect a link wire between L and SL.
Unplug all items connected to the 'Net' connections. Set the pressure setting to the minimum position.
- iii) Switch on the power supply, allow the fan to reach a steady speed (approx. 30 seconds). Adjust the pot marked Min to set the minimum speed.
- iv) After setting the speed, switch off the power and reconnect the wiring.

Setting the operating pressure

- i) Select a suitable location on the inlet side of the fan to read the static pressure of the system. This should be a straight section of ductwork, away from any obstructions or bends. Read the static pressure at this point using suitable instruments. If the control pressure tapping has been moved because of ancillaries fitted to the fan inlet, measure the static pressure at the new location.
- ii) Adjust the pressure setting using the potentiometer labelled for this purpose in the commissioning box until the pressure of the system reaches the desired level. The adjustment should be made slowly and allow the system to settle (approx. 30 seconds) before reading the pressure.
See table 5 for the maximum and minimum recommended operating pressure for each fan.

IMPORTANT

Isolation - Before commencing work make sure that the unit, switched live and Nuaire control are electrically isolated from the mains supply.

Warning - Inverter Speed Control

An Inverter is used to provide speed control. When the fan is isolated, allow 5 minutes for the capacitors in the inverter to discharge before commencing any work on the unit.

Maintenance Intervals

The first maintenance should be carried out three months after commissioning and thereafter at twelve monthly intervals. These intervals may need to be shortened if the unit is operating in adverse environmental conditions, or in heavily polluted air.

Note: failure to maintain the unit as recommended will invalidate the warranty.

Lubrication

Motors are fitted with sealed for life bearings and do not require any lubrication.

General Cleaning and Inspection

Clean and inspect the exterior of the fan unit and associated controls etc. Remove the access panel from the fan unit. Inspect and, if necessary, clean the fan and motor assemblies and the interior of the case. If the unit is heavily soiled it may be more convenient to remove the fan/motor assemblies.

Check that the shutters are free to move smoothly and that they seal the appropriate fan outlet effectively.

Clean and inspect each fan and motor assembly as follows; taking care not to damage, distort or disturb the balance of the impeller.

- a) Lightly brush away dirt and dust, paying particular attention to any build up at the motor ventilating slots. If necessary, carefully remove with a blade or scraper.
- b) Stubborn dirt at the impeller may be carefully removed with a stiff nylon brush.
- c) Check all parts for security and general condition. Check that the impeller rotates freely.

Refit the assemblies to the unit (see Replacement of Parts) then replace the access covers.

If Nuaire controls and or remote indicators are fitted, remove the covers and carefully clean out the interiors as necessary. Check for damage.

Check security of components. Refit the access covers.

Replacement of Parts

The only item of the fan units unit likely to require replacement are the fan/motor assemblies due to a failed motor or damaged impeller. In either eventuality the complete fan/motor assembly must be removed from the unit case.

Note: before commencing work, electrically isolate the fan unit and/or the associated Nuaire control, if fitted, from the mains supply.

Remove the access cover. Disconnect the incoming wiring from the connection box (located on the fan scroll) on the particular fan/motor assembly to be removed. Support the weight of the fan/motor assembly and remove the mounting screws and washers. Lift the assembly out of the case.

After replacing the faulty item, refit the fan/motor assembly and re-connect the incoming wiring to the fan mounted connection box. Replace the access cover.

Spare Parts

When ordering spares please quote the serial number of the unit together with the part number. If the part number is not known please give a full description of the part required. The serial number will be found on the identification plate attached to the unit casing.

Warranty

The 5 year warranty starts from the day of delivery and includes parts and labour for the first year.

The remaining period covers replacement parts only.

This warranty is conditional on planned maintenance being undertaken.

Service Enquiries

Nuaire can assist you in all aspects of service. Our service department will be happy to provide any assistance required, initially by telephone and if necessary arrange for an engineer to call.

Telephone 029 2085 8585
Fax 029 2085 8586

DECLARATION OF INCORPORATION AND INFORMATION FOR SAFE INSTALLATION, OPERATION AND MAINTENANCE

We declare that the machinery named below is intended to be assembled with other components to constitute a system of machinery. The machinery shall not be put into service until the system has been declared to be in conformity with the provisions of the EC Machinery Directive.

Designation of machinery: Ecosmart Constant Pressure Direct Drive Single & Twinfan



Machinery Types: ESTCP and ESXCP

Relevant EC Council Directives: 98/37/EC as amended by 98/79/EC (Machinery Directive)

Applied Harmonised Standards: BS EN ISO 12100-1, BS EN ISO 12100-2, EN294, EN60204-1, BS EN ISO 9001

Applied National Standards: BS848 Parts One, Two and Five

Signature of manufacture representatives:

Name:	Position:	Date:
1) C. Biggs	 Technical Director	20. 07. 07
2) W. Glover	 Manufacturing Director	20. 07. 07

INFORMATION FOR SAFE INSTALLATION, OPERATION AND MAINTENANCE OF NUAIRE VENTILATION EQUIPMENT

To comply with EC Council Directives 98/37/EC Machinery Directive and 2004/108/EC (EMC).

To be read in conjunction with the relevant Product Documentation (see 2.1)

1.0 GENERAL

- 1.1 The equipment referred to in this Declaration of Incorporation is supplied by Nuairé to be assembled into a ventilation system which may or may not include additional components.
The entire system must be considered for safety purposes and it is the responsibility of the installer to ensure that all of the equipment is installed in compliance with the manufacturers recommendations and with due regard to current legislation and codes of practice.

2.0 INFORMATION SUPPLIED WITH THE EQUIPMENT

- 2.1 Each item of equipment is supplied with a set of documentation which provides the information required for the safe installation and maintenance of the equipment. This may be in the form of a Data sheet and/or Installation and Maintenance instruction.
- 2.2 Each unit has a rating plate attached to its outer casing. The rating plate provides essential data relating to the equipment such as serial number, unit code and electrical data. Any further data that may be required will be found in the documentation. If any item is unclear or more information is required, contact Nuairé.
- 2.3 Where warning labels or notices are attached to the unit the instructions given must be adhered to.

3.0 TRANSPORTATION, HANDLING AND STORAGE

- 3.1 Care must be taken at all times to prevent damage to the equipment. Note that shock to the unit may result in the balance of the impeller being affected.
- 3.2 When handling the equipment, care should be taken with corners and edges and that the weight distribution within the unit is considered. Lifting gear such as slings or ropes must be arranged so as not to bear on the casing.
- 3.3 Equipment stored on site prior to installation should be protected from the weather and steps taken to prevent ingress of contaminants.

4.0 OPERATIONAL LIMITS

- 4.1 It is important that the specified operational limits for the equipment are adhered to e.g. operational air temperature, air borne contaminants and unit orientation.
- 4.2 Where installation accessories are supplied with the specified equipment eg. wall mounting brackets. They are to be used to support the equipment only. Other system components must have separate provision for support.
- 4.3 Flanges and connection spigots are provided for the purpose of joining to duct work systems. They must not be used to support the ductwork.

5.0 INSTALLATION REQUIREMENTS

In addition to the particular requirements given for the individual product, the following general requirements should be noted.

- 5.1 Where access to any part of equipment which moves, or can become electrically live are not prevented by the equipment panels or by fixed installation detail (eg ducting), then guarding to the appropriate standard must be fitted.
- 5.2 The electrical installation of the equipment must comply with the requirements of the relevant local electrical safety regulations.
- 5.3 For EMC all control and sensor cables should not be placed within 50mm or on the same metal cable tray as 230V switched live, lighting or power cables and any cables not intended for use with this product.

6.0 COMMISSIONING REQUIREMENTS

- 6.1 General pre-commissioning checks relevant to safe operation consist of the following:
Ensure that no foreign bodies are present within the fan or casing.
Check electrical safety. e.g. Insulation and earthing.
Check guarding of system.
Check operation of Isolators/Controls.
Check fastenings for security.
- 6.2 Other commissioning requirements are given in the relevant product documentation.

7.0 OPERATIONAL REQUIREMENTS

- 7.1 Equipment access panels must be in place at all times during operation of the unit, and must be secured with the original fastenings.
- 7.2 If failure of the equipment occurs or is suspected then it should be taken out of service until a competent person can effect repair or examination. (Note that certain ranges of equipment are designed to detect and compensate for fan failure).

8.0 MAINTENANCE REQUIREMENTS

- 8.1 Specific maintenance requirements are given in the relevant product documentation.
- 8.2 It is important that the correct tools are used for the various tasks required.
- 8.3 If the access panels are to be removed for any reason the electrical supply to the unit must be isolated.
- 8.4 A minimum period of two minutes should be allowed after electrical disconnection before access panels are removed. This will allow the impeller to come to rest.
NB: Care should still be taken however since airflow generated at some other point in the system can cause the impeller to "windmill" even when power is not present.
- 8.5 Care should be taken when removing and storing access panels in windy conditions.

Technical or commercial considerations may, from time to time, make it necessary to alter the design, performance and dimensions of equipment and the right is reserved to make such changes without prior notice.