

ES-JB Junction Box

Installation and Maintenance

Parts check list

- ES-JB Junction Box
- 1 off 10 metre length of plugged SELV cable

ES-JB Junction Box

Designed to be compatible with the Ecosmart system and to facilitate the connection of additional Ecosmart sensors via the nine additional network connections. The unit is supplied with a pre-plugged, 10 metre length of communications cable.

Note: longer lengths are available if required.

This unit must be connected to the 230V mains to provide adequate power supply to the sensors etc. connected to the network.

ES-JB can also be used to 'boost' power on the NET to facilitate the retro fitting of user control ES-LCD (see I&M data sheet 671415) to certain pre July 2009 and residential products.

Data cable installation

Do not run the SELV data cable in the same conduit as the mains cables and ensure there is a 50mm separation between the data cable and the other cables. The maximum cable run between the fan and sensor is 300 metres when

it is installed in accordance with the above instructions.

Please note that a maximum total data cable length used in any system must be less than 1000m. Keep the number of cable joints to a minimum to ensure the best data transmission efficiency between devices.

Installation

This unit must be fixed on a secured vertical surface which is free from vibration.

Remove the plastic cover (four screws).

Mark through the units fixing hole positions onto the mounting surface.

Figure 2. Dimensions ES-JB Junction Box.

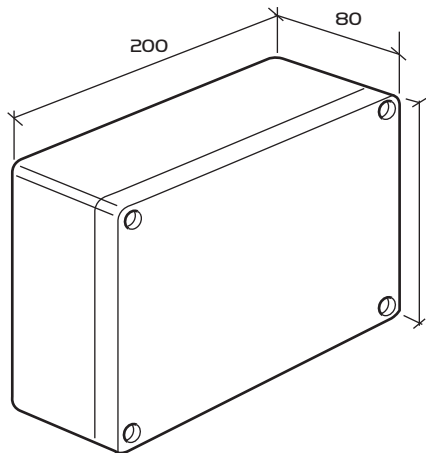

Drill and secure the unit using appropriate wallplugs screws etc.

Connect the mains supply into the unit as indicated in figure 1.

Note: The data cable connection can be made to any of the nine network sockets available. Note the data cable installation requirements in the previous section.

Maintenance

The unit does not require maintenance. However, for optimum performance, it is advisable to remove any accumulated dust with a low power vacuum cleaner.

Warranty

The 5 year warranty starts from the date of delivery and includes parts and labour for the first year.

The labour element is subject to full, free and safe access to the equipment as recommended by the CDM regulations. The remaining 4 years covers replacement parts only.

Service Enquiries

Nuaire can assist you in all aspects of service. Our service department will be happy to provide any assistance, initially by telephone and if necessary arrange for an engineer to call.

Telephone 029 2085 8585
Fax 029 2085 8586

Figure 1. Internal view of ES-JB Junction Box.

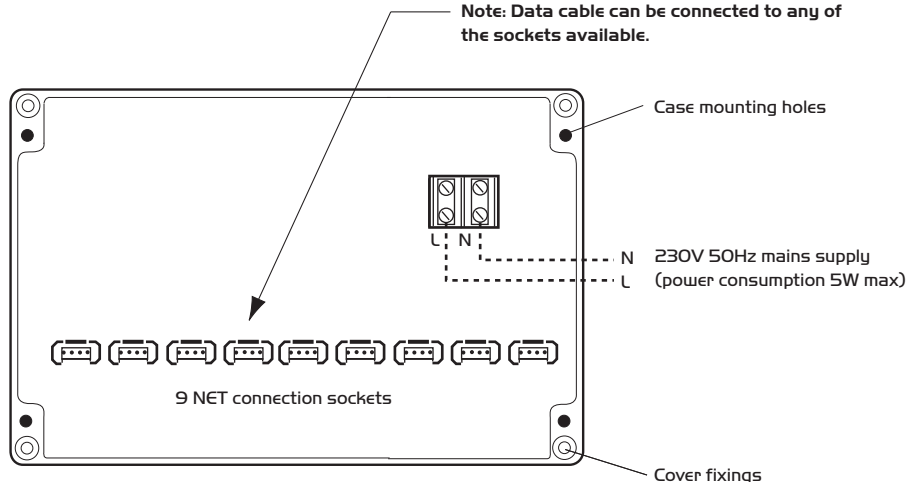

Technical or commercial considerations may, from time to time, make it necessary to alter the design, performance and dimensions of equipment and the right is reserved to make such changes without prior notice.