



3ph Belt Drive, Run & Standby, Roof & Plantroom Twinfans

Installation and Maintenance

EST-X

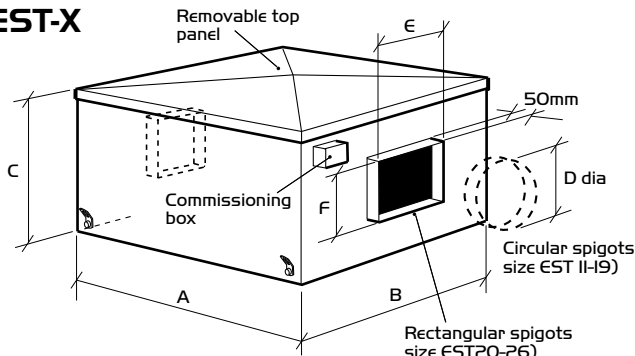

Figure 1. EST*-X Plantroom/roof mounted in line unit.

Unit	A	B	C	D dia	E	F
EST 11-X to EST 12-X	974	974	622	400	-	-
EST 13-X to EST 14-X	1233	1233	701	500	-	-
EST 15-X to EST 19-X	1430	1635	780	630	-	-
EST 20-X to EST 26-X	2030	2313	1183	-	1200	700

EST-R

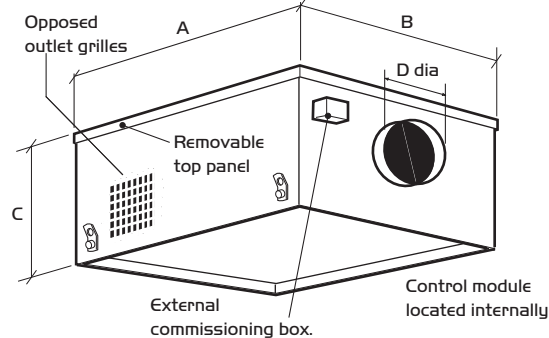

Figure 2. EST*-R Roof mounted end inlet, side discharge unit.

Unit	A	B	C	D dia
EST 11-R to EST 12-R	974	974	622	400
EST 13-R to EST 14-R	1233	1233	701	500
EST 15-R to EST 19-R	1430	1635	796	630

Introduction

The Nuair EST Twinfan Belt Drive range consists of the following units

EST-X (Duct Mounted, Plantroom/Roof) in line unit.

EST-R (Roof Mounted, end inlet) side discharge unit*.

EST-B (Roof Mounted bottom inlet) side discharge unit*.

* larger units have end discharge

Units are rectangular in section. The casing is manufactured from heavy gauge 'Aluzinc' aluminium-zinc coated mild steel. A full size internally lined access panel is fitted to the top face and this panel is fully detachable for inspection purposes.

The motor plate and frames are supported on the base by resilient mountings allowing the fan unit to be operated without the need for separate anti vibration fan case mountings.

The units incorporate two independent motors driving high efficiency, forward curved centrifugal impellers running in metal scrolls. Taper locked pulleys and wedge drive belts are employed. The fans discharge into a common outlet chamber through a shutter system that prevents 'blowback' through the standby fan. The motors are manufactured to BS5000 and are suitable for three phase supply.

Airflow and failure monitors are standard as is Class F insulation. Suitable for operation in ambient temperatures up to 40°C.

Handling

Always handle the units carefully to avoid damage and distortion. Eyebolts are provided on all units for lifting purposes.

If mechanical aids are used to lift the unit, spreaders should be employed and positioned so as to prevent the slings, webbing etc. making contact with the casing.

EST-B

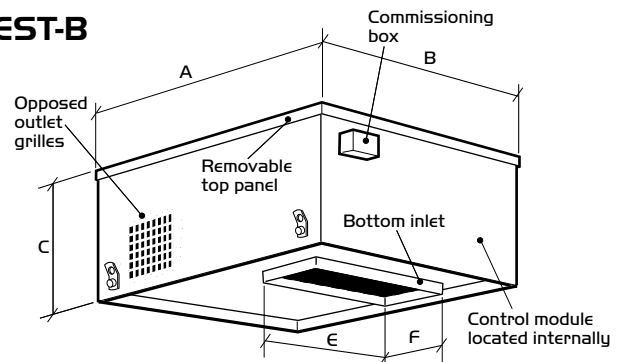

Figure 3. Bottom inlet unit.

Unit	A	B	C	E	F
EST 11-B to EST 12-B	974	974	622	457	229
EST 13-B to EST 14-B	1233	1233	701	762	304
EST 15-B to EST 19-B	1430	1635	796	889	381

EST-B/R larger units

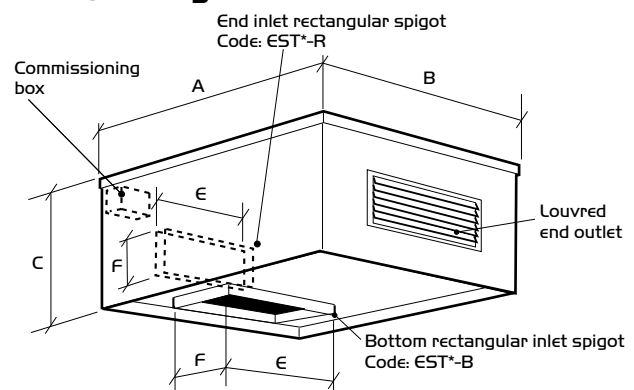

Figure 4. Bottom inlet unit.

Unit	A	B	C	E	F
EST 20-B to EST 26-B	2030	2313	1183	1200	700
EST 20-R to EST 26-R	2030	2313	1183	1200	700

Installation

IMPORTANT

The installation must be carried out by competent personnel in accordance with the appropriate authority and conforming to all statutory and governing regulations, ie IEE, COHSE, HVCA etc.

Units must not be installed at an angle over 5° from the horizontal (to ensure the backdraught shutters operate satisfactorily). Units must be installed with the access panel on top, never up-side-down.

Units should always be positioned with sufficient space to allow removal of the access covers and subsequent removal of fan and motor assemblies etc.

Ductwork connections must be airtight to prevent loss of performance.

The method of mounting used is the total responsibility of the installer. The lower edge of the casing has an internal skirt allowing the unit to be located on an upstand or prefabricated curb if desired. The units must be securely screw fixed to the upstand/curb to prevent vibration and/or wind damage.

It is the installers responsibility to drill the case to provide access for the electrical cables. Care should be taken not to damage internal components and the cable entry must be properly sealed. **NOTE: on bottom inlet units the electrical cabling may be routed up through the bottom inlet spigot.**

Testing after installation

Ensure that the Fan unit and any specified controls are fitted securely according to the instructions.

Switch on the mains supply. Push the test button to run each fan and check that they run satisfactorily.

If a switched live signal is used, activate this signal and check that the fan runs. De-activate the switched live signal and check the run-on-time; adjust if necessary.

Adjust the maximum and minimum airflow (if required) by following the commissioning procedures.

Prefabricated Curb

CODES: ESPFC* (typical)

Manufactured in pre galvanised steel these curbs will reduce design work and guarantee correct unit mounting when on site.

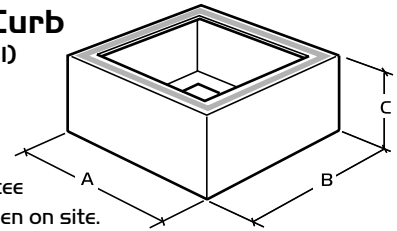

Figure 5.

Note: Upper faces of curb are fitted with robust sealing strip.

Table 5. Prefabricated curb dimensions (mm)

Unit Code	Prefab Curb Code	A	B	C
EST 11-12	ESPFC 4B	917	917	250
EST 13-14	ESPFC 5B	1173	1173	250
EST 15-19	ESPFC 6B	1374	1580	250

Upstand Details

Details of roof opening dimensions etc required and basic construction of a builders upstand etc are shown below for typical concrete and decking roof installations.

Figure 6. Roof curbs

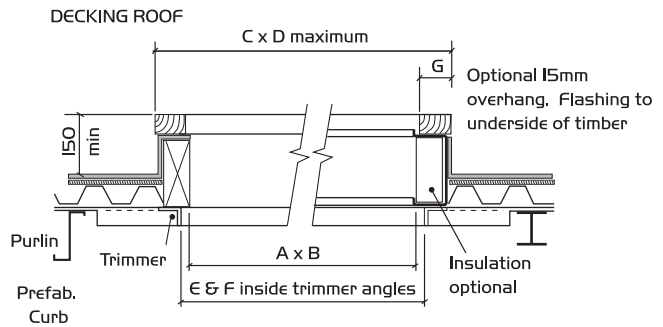
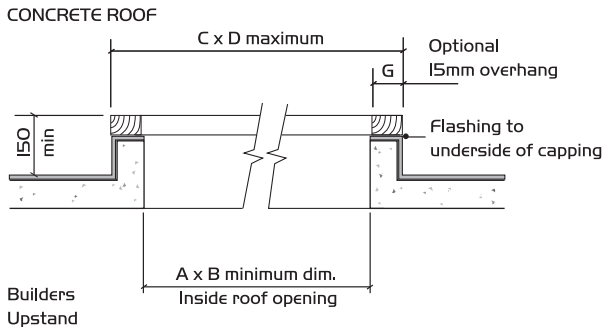

Table 6. Dimensions (mm)

Unit Code	Prefab Code	A	B	C	D	E	F	G
EST 11-12	ESPFC 4B	767	767	947	947	837	837	75
EST 13-14	ESPFC 5B	973	973	1203	1203	1064	1064	100
EST 15-19	ESPFC 6B	1169	1375	1399	1605	1268	1471	100

Note: Prefabricated curbs can be used to support internal or external units.

Typical Roof Upstand Requirements for Models EST20 to 26

Figure 7.

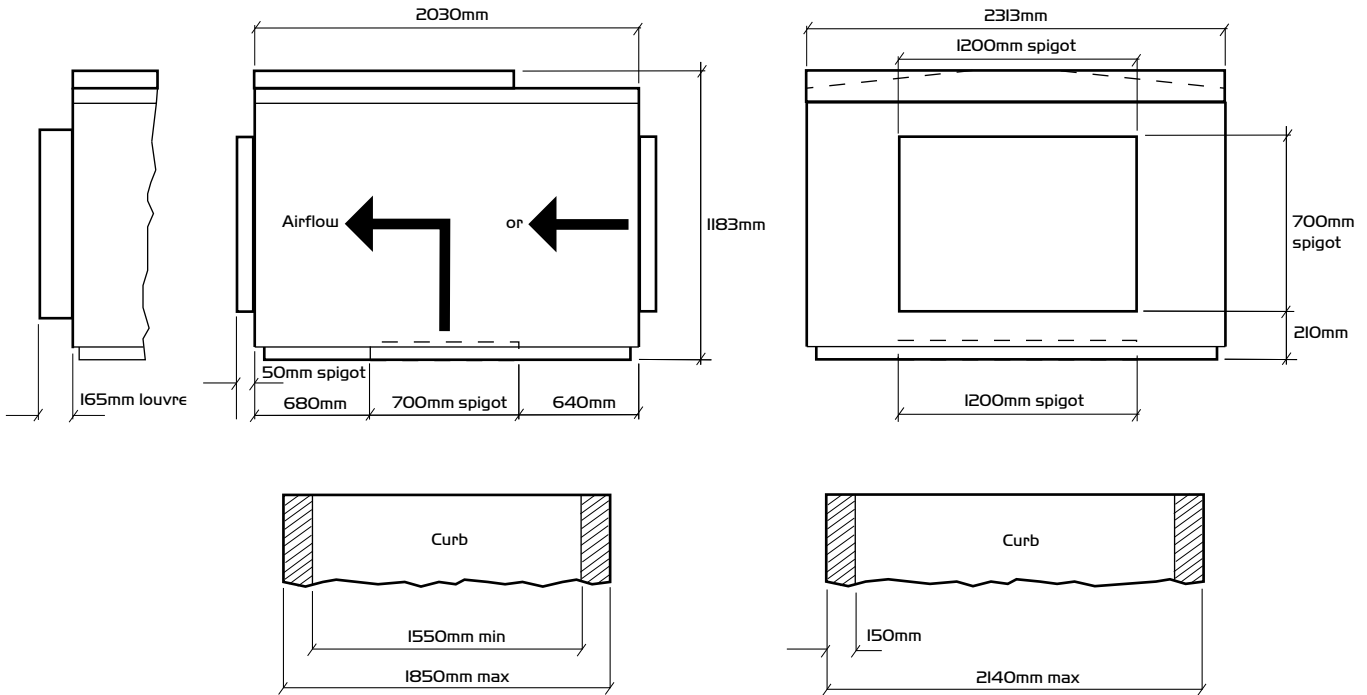

Electrical Details

IMPORTANT

Isolation - Before commencing work make sure that the unit, switched live and Nuairc control are electrically isolated from the mains supply.

Warning - Inverter Speed Control

An Inverter is used to provide speed control. When the fan is isolated, allow 5 minutes for the capacitors in the inverter to discharge before commencing any work on the unit.

by the 'fan law'). Failure to meet this condition will cause the motor to overload.

RDC

If a RDC is fitted to protect the circuit, a type B RDC should be used (trip limit 300mA). Otherwise nuisance tripping will occur.

NOTES: Because the run and start currents depend upon the duty and associated ductwork of an individual unit, the values quoted in table 7 are nominal.

Run currents will be exceeded if the unit is operated with its cover removed. The unit must not run for more than 2 minutes in this condition.

Motor Electrical Information Table 7. Run currents etc.

Unit Code*	Speed rpm	400V 3 Phase 50Hz Power (kW)	f l c # (amps)	Weight kg	Min Pa
EST 11 - *	1225	0.75	2.1	84.4	0
EST 12 - *	1400	1.1	2.9	90.4	0
EST 13 - *	1085	1.5	3.7	125	0
EST 14 - *	1225	2.2	5.4	134	100
EST 15 - *	1040	2.2	5.4	168.7	450
EST 16 - *	1040	4.0	10.0	193.6	100
EST 17 - *	1260	3.0	6.9	174.6	720
EST 18 - *	1260	5.5	12.0	231.6	320
EST 19 - *	1440	5.5	12.0	231.6	780
EST20 - *	700	5.5	12.0	730	100
EST 21 - *	800	4.0	10.0	716	450
EST22 - *	800	11.0	23.0	794	250
EST 23 - *	1000	5.5	12.0	730	720
EST24 - *	1000	11.0	23.0	794	450
EST25 - *	1100	11.0	23.0	794	720
EST26 - *	1200	11.0	23.0	794	1050

Start current not applicable as Ecosmart twinfans feature 'soft start'.

When the fans are running at maximum speed, the minimum static pressure across the fan must be higher than the values stated in table 7 (or the equivalent values as scaled

Electrical Installation typical layout

Figure 8. Typical internal layout.

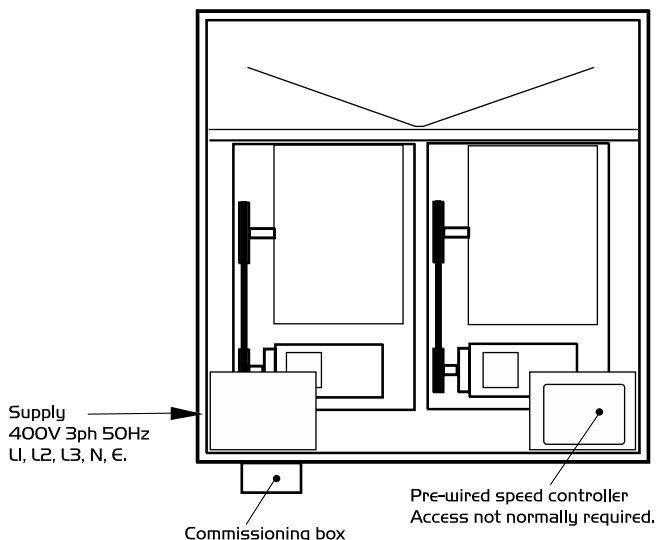

Connections

a) Mains connections

Mains cables should be suitably sized and terminated at terminals shown on the appropriate diagram.

b) Control Connections

Figure 9. 'Net' connection for Ecosmart devices.

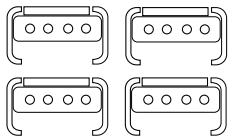

Net - the 4 IDC plug-in connectors are provided for the connection of compatible sensors, manual controls and for linking the fans together under a common control. If more than 4 connections are required, the junction box (product code ES-JB) should be used (see data cable installation).

c) Switched Live (SL) terminal

Figure 10.

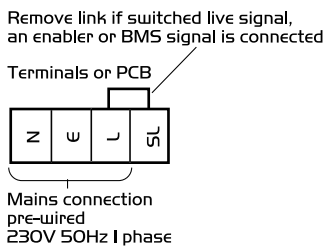

A signal of 100-230V a.c. will activate the fan from either its off state or trickle state (see setting to work-trickle switch). When the SL is disconnected the fan will over-run (see setting to work-timer adjustment).

Do not take this signal from an isolating transformer.

d) Damper connections

Figure 11a. Drive open/Spring close.

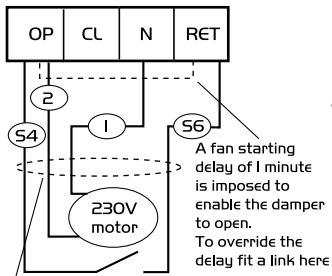

All wiring is IPh 230V 50Hz

Figure 11b. Drive open/ Drive close.

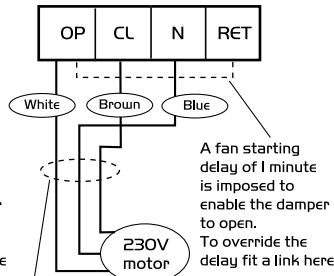

All wiring is IPh 230V 50Hz

OP - 230V 50Hz IA max supply to open the damper

CL - 230V 50Hz IA max supply to close the damper

N - Neutral supply to damper

RET - 230V ac return signal from the damper limit switch indicates the damper has reached its operating position. If the return signal is not present, the fan will wait for 1 minute before starting.

Note: If a damper is not fitted, connect a link wire from OP to RET. This will cancel the delay.

e) Volt Free Relay Contacts

Figure 12.

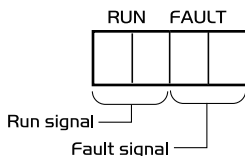

Note that the volt free contacts are not fused. If these are used to power any external equipment, the installer must provide adequate fusing or other protections.

These contacts are rated at 5A resistive, 0.5A inductive.

Run connections - These contacts are closed when the fan is running.

Fault connections - No fault = the contacts are closed.

Fault = the contacts are opened.

f) Data cable installation

A 4-core SELV data cable is used to connect devices.

Do not run data cable in the same conduit as the mains cables and ensure there is a 50mm separation between the data cable and other cables. The maximum cable run between any two devices is 300m when it is installed in accordance with the instructions.

Please note that the total data cable length used in any system must be less than 1000m. Keep the number of cable joints to a minimum to ensure the best data transmission efficiency between devices.

g) Maximum number of devices

The maximum number of devices (including fans) that can be connected together via the cable is 32, irrespective of their functions.

h) Other low voltage cables e.g. BMS signal

Follow the basic principle (as f). Keep the cable run as short as possible, less than 50 metres.

j) BMS input signals

The BMS connection is made with a plug-in connector via the socket (See figure 9).

To ensure the connection is made only by suitably qualified and authorised personnel the plug is not supplied.

It is available from **R S Components**, Part No. 403-875 or **Farnell**, Part No. 963-021.

Figure 13.

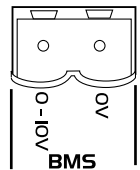

IMPORTANT

Reversal of the BMS connection will damage the control.

The system's response to a 0-10V dc BMS signal is given in the table below.

Note the BMS signal will override any sensors and user control connected in the system. The voltage tolerance is +/- 125mV and is measured at the fans terminal.

	Ventilation mode	Cooling mode*	Heating mode*
Local control	0.00	-	-
OFF / trickle	0.25	-	-
Speed 1	0.50	0.75	1.00
Speed 2	1.50	1.75	2.00
Speed 3	2.50	2.75	3.00
Speed 4	3.50	3.75	4.00
Speed 5	4.50	4.75	5.00
Speed 6	5.50	5.75	6.00
Speed 7	6.50	6.75	7.00
Speed 8	7.50	7.75	8.00
Speed 9	8.50	8.75	9.00
Speed 10	9.50	9.75	10.00

* Only available on relevant unit.

Figure I4. The Control Module

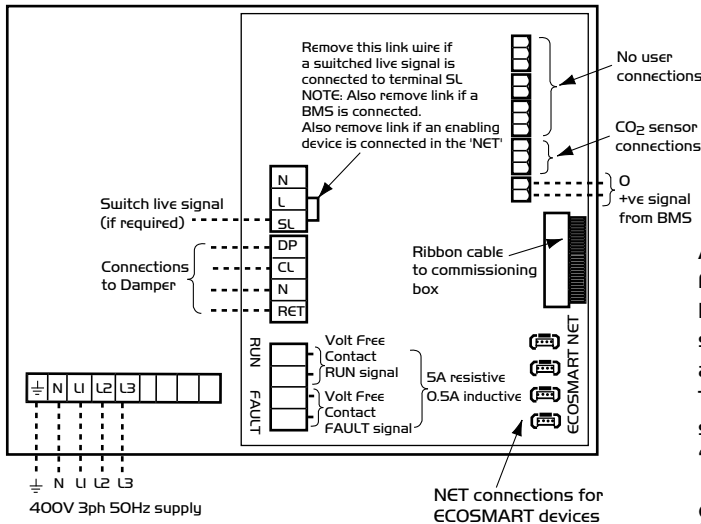

IMPORTANT

Please note this product must be earthed.
For good EMC engineering practice, any sensor cables or switched live cables should not be placed within 50mm of other cables or on the same metal cable tray as other cables.

Using the Test button

The test button allows the individual blowers within the unit to be checked for its operation. If the fan is running already, press the button once to stop the fan, press again to switch on the standby fan, press again to stop and so on.
Note that the fan will return to normal operation after 30 seconds.

Figure I5. Commissioning panel details.

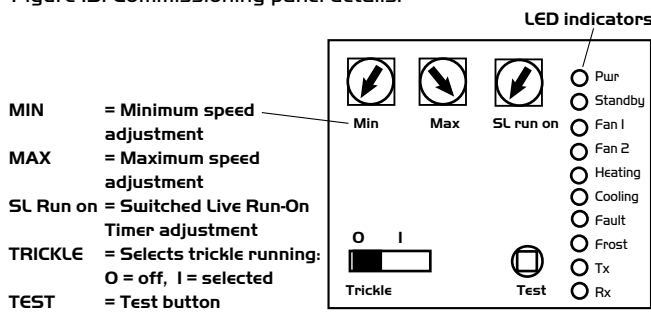

LED Indication

- PWR** GREEN: Power on & OK,
- Standby** LED on when fan is not running.
- Fan 1** GREEN: Fan 1 is running, RED: Fan 1 faulty.
- Fan 2** GREEN: Fan 2 is running, RED: Fan 2 faulty.
- Heating*** Not applicable. See note.
- Cooling*** Not applicable. See note.
- Fault** LED on when a fault is present on unit.
- Frost*** Not applicable. See note.
- Tx** LED on when the controller is transmitting data.
- Rx** LED on when the controller is receiving data.

* Note that the control panel is common to all the Ecosmart products and will have indicators for functions that are not available in this particular fan. However these indicators will not be illuminated.

Setting to Work

The Ecosmart twinfan is designed for maximum control flexibility. Apart from the power supply, an enabling signal is **always** required to set the fan running. This enabling signal can be a switched live signal (connected to the SL terminal of each fan) or an enabling device plugged in the NET connection.

If an enabling signal is not available, connect a link wire from 'L' to 'SL'.

Additional sensor and manual controls may be added. For example: to run the fan with a temperature sensor, connect a link across L to SL (enabling signal) and connect a temperature sensor in one of the sockets labelled 'NET' The fan will now adjust its speed according to temperature.

To obtain manual control, connect a link across L to SL (enabling signal) and connect a user control in one of the sockets labelled 'NET'.

Settings

Setting the Maximum airflow

- Ensure the power supply is switched off and that a link wire is connected from the supply L to the SL terminal. Unplug all items connected to the 'Net' connectors.
- Switch on the power supply.
NOTE: Ensure unit top cover is securely attached.
- Wait for the fan to complete its self-test operation.
- Remove the cover of the units external commissioning box. Measure the airflow using standard commissioning instruments at a suitable point in the ductwork. If adjustment is required, rotate the pot marked 'MAX' to obtain the desired airflow.

Setting the Minimum trickle airflow (nominal 20%)

- Repeat the same procedure as for maximum airflow above but without the link wire between supply L and SL terminal. Ensure the trickle switch is in the 'ON' position. The adjustment must be made on the pot marked 'Min'.
- For unit sizes EST20 to EST26, ensure the pressure across the fan is greater than 50 Pa at minimum speed. If the pressure is below 50Pa, this may result in a false failure signal. Adjust the minimum speed so that this does not occur.**
- Note that the minimum setting (nominally 20%) must be below the maximum setting, otherwise minimum setting will be automatically set to be the same as the maximum.

Maintenance

IMPORTANT

Isolation - Before commencing work make sure that the unit, switched live and Nuair control are electrically isolated from the mains supply.

Warning - Inverter Speed Control
An Inverter is used to provide speed control. When the fan is isolated, allow 5 minutes for the capacitors in the inverter to discharge before commencing any work on the unit.

Fan Unit Maintenance Intervals

The first maintenance should be carried out three months after commissioning and thereafter at twelve monthly intervals. These intervals may need to be shortened if the unit is operating in adverse environmental conditions, or in heavily polluted air. Access to the unit internals is gained by removing the top cover(s).

Maintenance cont.

Motors

Brush away any dust or dirt from the motor housings and ensure that the motor vents are unblocked.

Bearings

Lubrication is unnecessary as the motors are fitted with sealed for life bearings.

Impellers

Remove any dust and check that the impellers are securely fixed to the motor shafts. Take care not to disturb any balance weights fitted. Check sealed for life bearings for excessive wear.

Shutter Assembly

Remove any dust and check that the shutters operate freely and that they seal the appropriate fan outlet effectively.

Figure 16. Shutter detail.

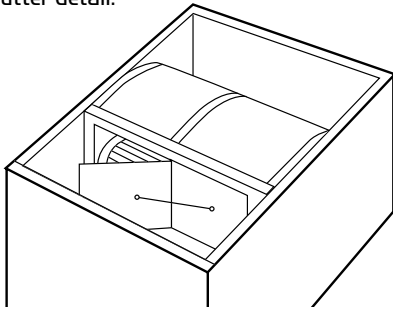

Anti Vibration Motor Plate Mountings

Each motor plate is supported on individual resilient mountings. Check that all the mountings are secure and in good condition.

Adjusting Drive Belt Tension (EST II-19)

To check the correct tension of a drive belt, apply a force at right angles to the centre of the belt span sufficient to deflect the belt 16mm for every metre of span length (see figure 17). The force required to deflect the 'V' belt should be from 0.5kg to 0.8kg. The tension of the belt should be checked after 24 hours of continuous running and adjusted as necessary.

Figure 17. Adjusting the drive belts (EST II-19).

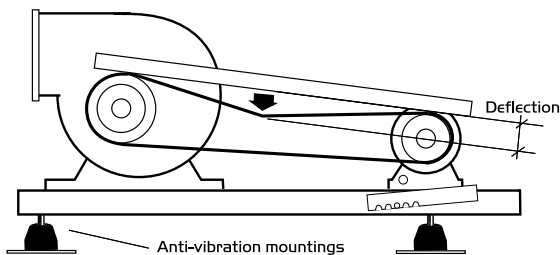

Changing a Drive Belt

To replace a belt, remove the two bolts from the motor mounting furthest from the fan and slacken the remaining two bolts. Lift the motor plate and remove the belt. Replacing the belt is the reverse of this procedure.

Adjusting Drive Belt Tension (EST 20-26)

All belt drive units incorporate belt tensioning devices.

To adjust the belt tension, slacken the pinch bolt on the sides of the motor plate. Turn the adjusting bolt clockwise to tighten the belt and counter clockwise to loosen it.

The drive should be tensioned until a slight bow appears in the slack side of the 'V' belt when running under load.

Figure 18. Adjusting the drive belts (EST 20-26).

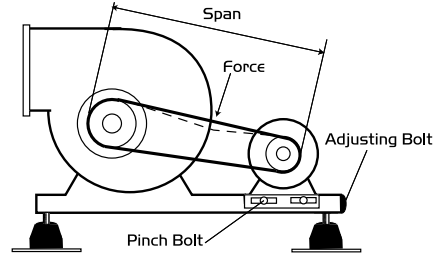

To check for correct tension, proceed as follows:

1. Measure the span length (See figure 18).
2. At the centre of the span, apply a force at right angles to the belt sufficient to deflect one belt 16mm for every metre of span length (see figure 18). The force required to deflect the 'V' belt should be from 0.5kg to 0.8kg.
3. Tighten the pinch bolts.

General Cleaning and Inspection

Clean and inspect the exterior of the fan unit and associated controls etc. Remove the access panel from the fan unit. Inspect and, if necessary, clean the fan and motor assemblies and the interior of the case. If the unit is heavily soiled it may be more convenient to remove the fan/motor assemblies. If Nuaire controls and or remote indicators are fitted, remove the covers and carefully clean out the interiors as necessary. Check for damage. Check security of components. Refit the access covers.

General

1. Check that all fixings are tight.
2. Check sealing strips around the fan outlets are tight up against the bulkhead.
3. Check that duct connections are not leaking.

Warranty

The 5 year warranty starts from the day of delivery and includes parts and labour for the first year. The remaining period covers replacement parts only. This warranty is conditional on planned maintenance being undertaken.

Service Enquiries

Nuaire can assist you in all aspects of service. Our service department will be happy to provide any assistance required, initially by telephone and if necessary arrange for an engineer to call within 48 hours if possible.



Telephone 029 2085 8585
Fax 029 2085 8586

DECLARATION OF INCORPORATION AND INFORMATION FOR SAFE INSTALLATION, OPERATION AND MAINTENANCE

We declare that the machinery named below is intended to be assembled with other components to constitute a system of machinery. The machinery shall not be put into service until the system has been declared to be in conformity with the provisions of the EC Machinery Directive.

Designation of machinery: Ecosmart Belt Drive Twinfan
Machinery Types: EST
Relevant EC Council Directives: 98/37/EC as amended by 98/79/EC (Machinery Directive)
Applied Harmonised Standards: BS EN ISO 12100-1, BS EN ISO 12100-2, EN294, EN60204-1, BS EN ISO 9001
Applied National Standards: BS848 Parts One, Two and Five

Signature of manufacture representatives:

Name:	Position:	Date:
1) C. Biggs 	Technical Director	20. 07. 07
2) W. Glover 	Manufacturing Director	20. 07. 07

INFORMATION FOR SAFE INSTALLATION, OPERATION AND MAINTENANCE OF NUAIRE VENTILATION EQUIPMENT

To comply with EC Council Directives 98/37/EC Machinery Directive and 2004/108/EC (EMC).

To be read in conjunction with the relevant Product Documentation (see 2.1)

1.0 GENERAL

1.1 The equipment referred to in this Declaration of Incorporation is supplied by Nuairé to be assembled into a ventilation system which may or may not include additional components.
 The entire system must be considered for safety purposes and it is the responsibility of the installer to ensure that all of the equipment is installed in compliance with the manufacturers recommendations and with due regard to current legislation and codes of practice.

2.0 INFORMATION SUPPLIED WITH THE EQUIPMENT

2.1 Each item of equipment is supplied with a set of documentation which provides the information required for the safe installation and maintenance of the equipment. This may be in the form of a Data sheet and/or Installation and Maintenance instruction.
 2.2 Each unit has a rating plate attached to its outer casing. The rating plate provides essential data relating to the equipment such as serial number, unit code and electrical data. Any further data that may be required will be found in the documentation. If any item is unclear or more information is required, contact Nuairé.
 2.3 Where warning labels or notices are attached to the unit the instructions given must be adhered to.

3.0 TRANSPORTATION, HANDLING AND STORAGE

3.1 Care must be taken at all times to prevent damage to the equipment. Note that shock to the unit may result in the balance of the impeller being affected.
 3.2 When handling the equipment, care should be taken with corners and edges and that the weight distribution within the unit is considered. Lifting gear such as slings or ropes must be arranged so as not to bear on the casing.
 3.3 Equipment stored on site prior to installation should be protected from the weather and steps taken to prevent ingress of contaminants.

4.0 OPERATIONAL LIMITS

4.1 It is important that the specified operational limits for the equipment are adhered to e.g. operational air temperature, air borne contaminants and unit orientation.
 4.2 Where installation accessories are supplied with the specified equipment eg. wall mounting brackets. They are to be used to support the equipment only. Other system components must have separate provision for support.
 4.3 Flanges and connection spigots are provided for the purpose of joining to duct work systems. They must not be used to support the ductwork.

5.0 INSTALLATION REQUIREMENTS

In addition to the particular requirements given for the individual product, the following general requirements should be noted.

5.1 Where access to any part of equipment which moves, or can become electrically live are not prevented by the equipment panels or by fixed installation detail (eg ducting), then guarding to the appropriate standard must be fitted.
 5.2 The electrical installation of the equipment must comply with the requirements of the relevant local electrical safety regulations.
 5.3 For EMC all control and sensor cables should not be placed within 50mm or on the same metal cable tray as 230V switched live, lighting or power cables and any cables not intended for use with this product.

6.0 COMMISSIONING REQUIREMENTS

6.1 General pre-commissioning checks relevant to safe operation consist of the following:
 Ensure that no foreign bodies are present within the fan or casing.
 Check electrical safety. e.g. Insulation and earthing.
 Check guarding of system.
 Check operation of Isolators/Controls.
 Check fastenings for security.
 6.2 Other commissioning requirements are given in the relevant product documentation.

7.0 OPERATIONAL REQUIREMENTS

7.1 Equipment access panels must be in place at all times during operation of the unit, and must be secured with the original fastenings.
 7.2 If failure of the equipment occurs or is suspected then it should be taken out of service until a competent person can effect repair or examination. (Note that certain ranges of equipment are designed to detect and compensate for fan failure).

8.0 MAINTENANCE REQUIREMENTS

8.1 Specific maintenance requirements are given in the relevant product documentation.
 8.2 It is important that the correct tools are used for the various tasks required.
 8.3 If the access panels are to be removed for any reason the electrical supply to the unit must be isolated.
 8.4 A minimum period of two minutes should be allowed after electrical disconnection before access panels are removed. This will allow the impeller to come to rest. **NB: Care should still be taken however since airflow generated at some other point in the system can cause the impeller to "windmill" even when power is not present.**
 8.5 Care should be taken when removing and storing access panels in windy conditions.



Nuaire Group
Western Industrial Estate
Caerphilly United Kingdom
CF83 1NA
T: 029 2088 5911
F: 029 2088 7033
E: info@nuaire.co.uk
W: www.nuaire.co.uk