



ECOSMART TWINFANS (EST-X/R/B) I phase, Direct Drive, Run & Standby For External, Roof Mounted and Internal use Installation and Maintenance

EST-X

Figure 1. EST-X unit.

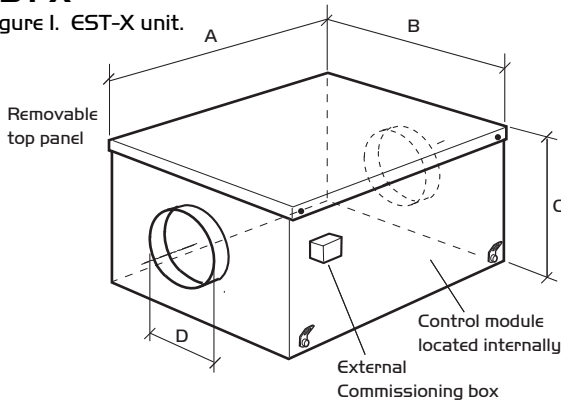

Table 1. EST-X Dimensions (mm)

Code	A	B	C	D dia.	Weight (kg)
EST1-X	705	505	355	125	22
EST2-X	875	720	400	200	35
EST3-X	970	720	485	200	50
EST4-X	1165	980	575	250	72
EST5-X	1165	980	575	400	75
EST6-X	1165	980	575	400	86
EST9-X	1495	1125	710	500	162

EST-R & EST-B

Figure 2. EST-R/B units.

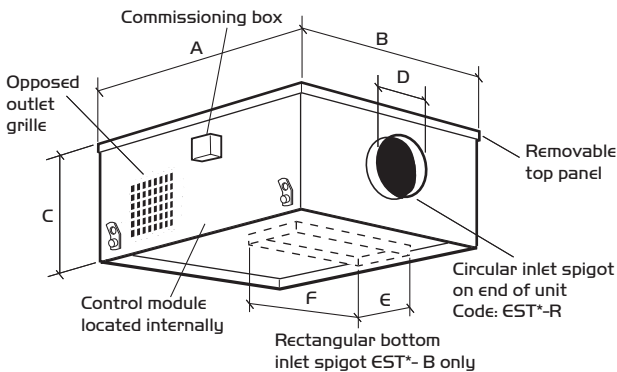

Table 2. EST-R / B Dimensions (mm)

Unit	A	B	C	D dia.	E	F	Weight (kg)
EST1-R	705	505	355	125	-	-	22
EST1-B	705	505	355	-	76	152	22
EST2-R	875	720	400	200	-	-	35
EST2-B	875	720	400	-	127	229	35
EST3-R	970	720	485	200	-	-	45
EST3-B	970	720	485	-	127	229	45
EST4-R	1165	980	575	250	-	-	72
EST4-B	1165	980	575	-	152	305	72
EST5-R	1165	980	575	400	-	-	75
EST5-B	1165	980	575	-	229	457	75
EST6-R	1165	980	575	400	-	-	86
EST6-B	1165	980	575	-	229	457	86
EST9-R	1495	1125	710	500	-	-	162
EST9-B	1495	1125	710	-	304	762	162

Introduction

Units are rectangular in section and consist of three basic designs.

Full size access panels are fitted to the top of the units and are fully detachable for inspection and connection purposes.

The models are coded as follows:

EST-X (External/Internal Duct Mounted) in line unit.

EST-R (Roof Mounted, end inlet) side discharge unit.

EST-B (Roof Mounted bottom inlet) side discharge unit.

EST-X units are rectangular in section and have circular rigid spigots at each end.

EST-R units are rectangular in section and are supplied with a circular end spigot and two opposed side discharge grilles.

EST-B units are rectangular in section and have a rectangular bottom spigot and two opposed side discharge grilles.

Handling

Always handle the units carefully to avoid damage and distortion. If mechanical aids are used to lift the unit, spreaders should be employed and positioned so as to prevent the slings, webbing etc. making contact with the casing.

Installation

Installers - please note that Installation must be carried out by competent personnel in accordance with the appropriate authority and conforming to all statutory and governing regulations e.g. I.E.E, CIBSE, COHSE.

EST-X/R/B units are suitable for internal or external use.

All units can be installed at any angle up to 60° however, on a sloping roof the unit must be blowing upwards toward the roof ridge to ensure correct backdraught shutter operation.

Units should always be positioned with sufficient space to allow removal of the access cover and subsequent removal of fan and motor assemblies etc.

Whether internally or externally mounted, the method of fixing to the roof is the responsibility of the installer.

All units have a bottom skirt to allow for fixing directly onto a suitably sized curb or builders upstand. Nuairé can supply a matching prefabricated curb for these units. Details of curbs and dimensions for a suitable external concrete upstand are shown on page 2.

Ductwork connections must be airtight to prevent any loss of performance.

All units have an internal connection box requiring connection to the mains supply on installation. It is the installers responsibility to drill the case to provide access for the electrical cables. Care should be taken not to damage internal components and the cable entry should be properly sealed.

A small commissioning box is provided on the outside of the case.

NOTE: A Commissioning Procedure document (leaflet No. 671154) is available on request from the Nuair Technical Library Tel: 02920 885911.

The unit should be securely screwed to its curb or mounting to prevent vibration and/or wind damage. Note that on the bottom inlet (EST-B) units, the cabling could be carried up from inside the building through the bottom inlet spigot.

Roof Upstand Mounting

Casing skirt depth

The fan casings have an inside skirt depth of 60mm or, in the case of the largest size units only, 50mm.

It is recommended that the units are mounted upon a suitable curb or upstand which has a minimum height of 150mm (inclusive of the timber capping if applicable, see curb dimensions).

This mounting height provides adequate distance to avoid any standing water on the roof being drawn into the fan (this can occur on bottom inlet installations if a unit is not properly installed and an air leak in the unit /ductwork joint is pulling air over the curb. The recommended height will also ensure that the unit does not 'stand' on its skirt edge.

Prefabricated Curb

CODES: ESPFC* (typical)

Manufactured in pre galvanised steel these curbs will reduce design work and guarantee correct unit mounting when on site.

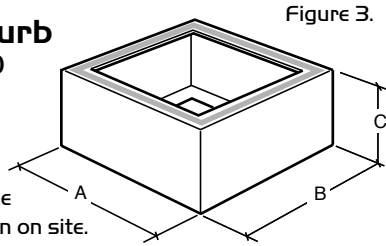

Figure 3.

Note: Upper faces of curb are fitted with robust sealing strip.

Table 3. Prefabricated curb dimensions (mm)

Unit Code	Prefab Curb Code	A	B	C
EST1.*	ESPFC1	635	435	250
EST2.*	ESPFC2	805	650	250
EST3.*	ESPFC3	900	650	250
EST4.*	ESPFC4	1095	910	250
EST5.*	ESPFC4	1095	910	250
EST6.*	ESPFC4	1095	910	250
EST9.*	ESPFC5	1425	1045	250

Roof Opening and Curb Dimensions

Figure 4. Roof curbs

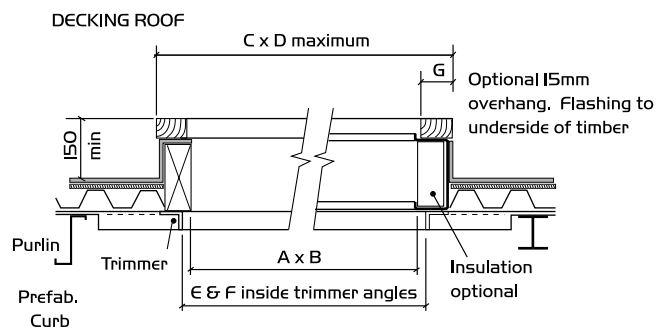
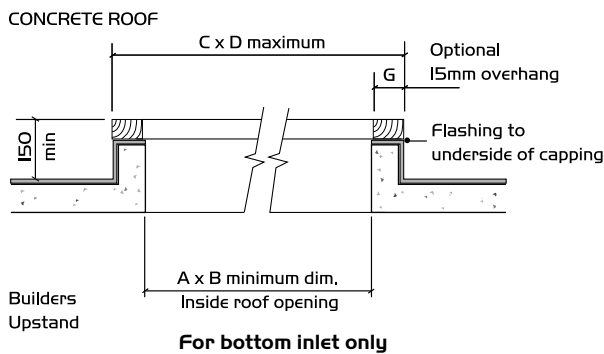

Table 4. Dimensions (mm)

Unit Code	Prefab Code	A	B	C	D	E	F	G
EST1.*	ESPFC 1	535	335	665	465	621	421	50
EST2.*	ESPFC 2	700	550	830	680	791	636	50
EST3.*	ESPFC 3	795	550	925	680	886	636	50
EST4.*	ESPFC 4	940	760	1120	940	1105	920	75
EST5.*	ESPFC 4	940	760	1120	940	1105	920	75
EST6.*	ESPFC 4	940	760	1120	940	1105	920	75
EST9.*	ESPFC 5	1265	900	1445	1080	1435	1065	75

Electrical Detail

Because the run and start currents depend upon the duty and associated ductwork of an individual unit, run currents will be exceeded if the unit is operated with its cover removed. It is therefore recommended that the unit is not run for prolonged periods in this condition.

IMPORTANT

Isolation - Before commencing work make sure that the unit, switched live and Nuaire control are electrically isolated from the mains supply.

Testing after installation

Ensure that the Fan unit and any specified controls are fitted securely according to the instructions.

Switch on the mains supply. Push the test button to run each fan and check that they run satisfactorily.

Wiring Connections

Fig. 5. Control module connection details inside fan.

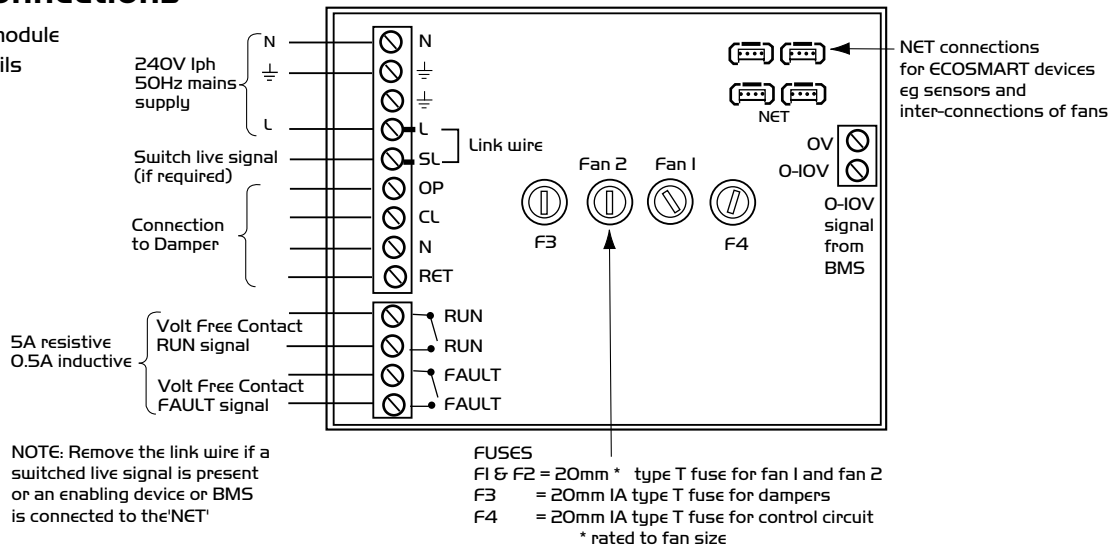

I.O Connections

a) Control Connections (see fig. 5).

Net - the 4 IDC plug-in connectors are provided for the connection of compatible sensors, manual controls and for linking the fans together under a common control. If more than 4 connections are required, junction box (product code ES-JB) should be used.

Note: Do not run the SELV data cable in the same conduit as the mains cable and leave a 50mm separation with any power cables.

Switch Live (SL) terminal - A signal of 100-230V a.c. will activate the fan. Note that a signal from an isolating transformer will produce an unpredictable result and is not recommended.

b) Damper connections

- OP** - 230V 50Hz IA max supply to open the damper
- CL** - 230V 50Hz IA max supply to close the damper
- N** - Neutral supply to damper
- RET** - 230V ac return signal from the damper limit switch to indicate the damper has reached its operating position. If the return signal is not present, the fan will wait for 1 minute before starting.

Note: If a damper is not fitted, connect a link wire from OP to RET. This will cancel the delay.

If a switched live signal is used, activate this signal and check that the fan runs. De-activate the switched live signal and check the run-on-time; adjust if necessary.

Adjust the set point of any sensors and PIR; check that they function correctly.

Adjust the maximum and minimum airflow (if required) by following the commissioning procedures.

Motor Electrical Information Table 5.

230V single phase 50Hz only

Unit Code	Fuse rating
EST 1	2A
EST 2	2A
EST 3	3.15A
EST 4	3.15A
EST 5	6A
EST 6	8A
EST 8	10A
EST 9	10A

c) Volt Free Relay Contacts

Note that the volt free contacts are not fused. If these are used to power any external equipment, the installer must provide adequate fusing or other protections.

These contacts are rated at 5A resistive, 0.5A inductive.

Run connections - These contacts are closed when the fan is running.

Fault connections - No fault = the contacts are closed. Fault = the contacts are opened (this includes no power supply at the unit).

d) Data Cable installation

A 4-core SELV data cable is used to connect devices such as sensors to the fan and for interconnecting multiple fan units. Do not run data cable in the same conduit as the mains cables and ensure there is a 50mm separation between the data cable and other cables.

The maximum cable run between any two devices is 300m when it is installed in accordance with the instructions. Please note that the total data cable length used in any system must be less than 1000m. Keep the number of cable joints to a minimum to ensure the best data transmission efficiency between devices.

e) Maximum number of devices

The maximum number of devices (including fans) that can be connected together via the data cable is 32, irrespective of their functions.

Connections continued.

Fig. 6 External Commissioning Box details.

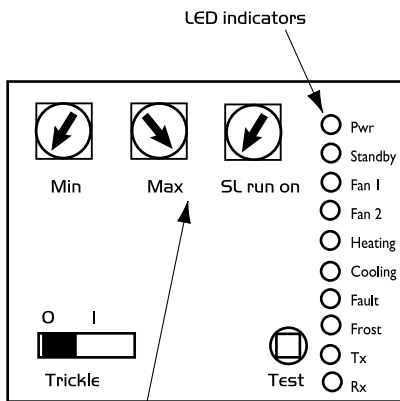

- MIN = Minimum speed adjustment
- MAX = Maximum speed adjustment
- SL run on = Switched Live Run-On Timer adjustment
- TRICKLE = Selects trickle running. 0 = off, I = selected
- TEST = Test button

NOTE: A Commissioning Procedure document (leaflet No. 671154) is available on request from the Nuair Technical Library Tel: 02920 885911.

2.0 Using the Test button (see fig. 6).

The test button allows the individual blowers within the unit to be checked for its operation. If the fan is running already, press the button once to stop the fan, press again to switch on the standby fan, press again to stop and so on.

Note that the fan will return to normal operation after 30 seconds.

3.0 LED Indication (see fig. 6).

- PWR** GREEN: Power on & OK. RED: Too much power is taken by peripherals or there is a short circuit in the net cable. Check the cable and use a junction box (ES-JB) to connect some of the peripherals.
- Standby** LED on when fan is not running.
- Fan 1** GREEN: Fan 1 is running, RED: Fan 1 faulty.
- Fan 2** GREEN: Fan 2 is running, RED: Fan 2 faulty.
- Heating*** Not applicable. See note.
- Cooling*** Not applicable. See note.
- Fault** LED on when a fault is present on unit.
- Frost*** Not applicable. See note.
- Tx** LED on when the controller is transmitting data.
- Rx** LED on when the controller is receiving data.

* Note that the control panel is common to all the Ecosmart products and will have indicators for functions that are not available in this particular fan. However these indicators will not be illuminated.

4.0 BMS input signals

The systems response to a 0-10V dc BMS signal is given in the following table. Note the BMS signal will override any sensors and user control connected in the system.

The voltage tolerance is +/- 125mV and is measured at the fans terminal.

Table 6.

	Ventilation mode	Cooling mode*	Heating mode*
Local control	0.00	-	-
OFF/trickle	0.25	-	-
Speed 1	0.50	0.75	1.00
Speed 2	1.50	1.75	2.00
Speed 3	2.50	2.75	3.00
Speed 4	3.50	3.75	4.00
Speed 5	4.50	4.75	5.00
Speed 6	5.50	5.75	6.00
Speed 7	6.50	6.75	7.00
Speed 8	7.50	7.75	8.00
Speed 9	8.50	8.75	9.00
Speed 10	9.50	9.75	10.00

* Only available on relevant unit

5.0 Setting the airflow

Setting the maximum air flow

i) Ensure the power supply is switched off and that a link wire is connected from the supply L to the SL terminal. Unplug all items connected to the 'Net' connectors.

ii) Switch on the power supply.

Note: Ensure unit cover is securely attached.

iii) Wait for the fan to complete its self-test operation.

iv) Remove the cover of the units external commissioning box. Measure the airflow using standard commissioning instruments at a suitable point in the ductwork. If adjustment is required, rotate the pot marked 'MAX' to obtain the desired airflow.

Setting the minimum trickle airflow (nominally 40%)

i) Repeat the same procedure as for maximum airflow above but without the link wire between supply L and SL terminal. Ensure the trickle switch is in the 'ON' position. The adjustment must be made on the pot marked 'Min'.

ii) Note that the minimum setting (nominally 40%) must be below the maximum setting, otherwise minimum setting will be automatically set to be the same as the maximum.

After setting the airflows, re-connect all the items disconnected previously. Ensure that the cover over the mains terminals is replaced and that the cover of the controls enclosure is securely fastened.

IMPORTANT

For good EMC engineering practice, any sensor cables or switched live cables should not be placed within 50mm of other cables or on the same metal cable tray as other cables.

Maintenance (General)

IMPORTANT

Isolation - Before commencing work make sure that the unit, switched live and Nuair control are electrically isolated from the mains supply.

Maintenance Intervals

The first maintenance should be carried out three months after commissioning and thereafter at twelve monthly intervals. These intervals may need to be shortened if the unit is operating in adverse environmental conditions, or in heavily polluted air. NOTE: Failure to maintain the unit as recommended will invalidate the warranty.

Lubrication

Motors are fitted with sealed for life bearings and therefore require no further lubrication.

General Cleaning and Inspection

Clean and inspect the exterior of the fan unit and associated controls etc. Remove the access panel from the fan unit. Inspect and, if necessary, clean the fan and motor assemblies and the interior of the case. If the unit is heavily soiled it may be more convenient to remove the fan / motor assemblies.

Check that the shutters are free to move smoothly and that they seal the appropriate fan outlet effectively.

Clean and inspect each fan and motor assembly as follows; taking care not to damage, distort or disturb the balance of the impeller.

- a) Lightly brush away dirt and dust, paying particular attention to any build up at the motor ventilating slots. If necessary, carefully remove with a blade or scraper.
- b) Stubborn dirt at the impeller may be carefully removed with a stiff nylon brush.
- c) Check all parts for security and general condition. Check that the impeller rotates freely.

Refit the assemblies to the unit (see Replacement of Parts) then replace the access cover.

If Nuair controls and or remote indicators are fitted, remove the cover and carefully clean out the interiors as necessary. Check for damage.

Check security of components. Refit the access cover.

Replacement of Parts

The only item of the fan units unit likely to require replacement are the fan/motor assemblies due to a failed motor or damaged impeller. In either eventuality the complete fan/ motor assembly must be removed from the unit case.

Remove the access cover. Disconnect the incoming wiring from the connection box (located on the fan scroll) on the particular fan/motor assembly to be removed. Support the weight of the fan/motor assembly and remove the mounting screws and washers. Lift the assembly out of the case.

After replacing the faulty item, refit the fan/motor assembly and re-connect the incoming wiring to the fan mounted connection box. Replace the access cover.

Spare Parts

When ordering spares please quote the serial number of the unit together with the part number. If the part number is not known please give a full description of the part required. The serial number will be found on the identification plate attached to the unit casing.

Warranty

The 5 year warranty starts from the day of delivery and includes parts and labour for the first year. The remaining 4 years covers replacement parts only. This warranty is conditional on planned maintenance being undertaken.

Service Enquiries

As a manufacturer Nuair provides you with factory trained Service Engineers. Our Service Department will be happy to give you more information.



Telephone 029 2085 8585
Fax 029 2085 8586

DECLARATION OF INCORPORATION AND INFORMATION FOR SAFE INSTALLATION, OPERATION AND MAINTENANCE

We declare that the machinery named below is intended to be assembled with other components to constitute a system of machinery. The machinery shall not be put into service until the system has been declared to be in conformity with the provisions of the EC Machinery Directive.

Designation of machinery: Ecosmart Direct Drive Twinfans
Machinery Types: EST-X, EST-R and EST-B
Relevant EC Council Directives: 98/37/EC as amended by 98/79/EC (Machinery Directive)
Applied Harmonised Standards: BS EN ISO 12100-1, BS EN ISO 12100-2, EN294, EN60204-1, BS EN ISO 9001
Applied National Standards: BS848 Parts One, Two and Five

Signature of manufacture representatives:

Name:	Position:	Date:
1) C. Biggs 	Technical Director	20. 07. 07
2) W. Glover 	Manufacturing Director	20. 07. 07

INFORMATION FOR SAFE INSTALLATION, OPERATION AND MAINTENANCE OF NUAIRE VENTILATION EQUIPMENT

To comply with EC Council Directives 98/37/EC Machinery Directive and 2004/108/EC (EMC).

To be read in conjunction with the relevant Product Documentation (see 2.1)

1.0 GENERAL

- 1.1 The equipment referred to in this Declaration of Incorporation is supplied by Nuairé to be assembled into a ventilation system which may or may not include additional components.
 The entire system must be considered for safety purposes and it is the responsibility of the installer to ensure that all of the equipment is installed in compliance with the manufacturers recommendations and with due regard to current legislation and codes of practice.

2.0 INFORMATION SUPPLIED WITH THE EQUIPMENT

- 2.1 Each item of equipment is supplied with a set of documentation which provides the information required for the safe installation and maintenance of the equipment. This may be in the form of a Data sheet and/or Installation and Maintenance instruction.
 2.2 Each unit has a rating plate attached to its outer casing. The rating plate provides essential data relating to the equipment such as serial number, unit code and electrical data. Any further data that may be required will be found in the documentation. If any item is unclear or more information is required, contact Nuairé.
 2.3 Where warning labels or notices are attached to the unit the instructions given must be adhered to.

3.0 TRANSPORTATION, HANDLING AND STORAGE

- 3.1 Care must be taken at all times to prevent damage to the equipment. Note that shock to the unit may result in the balance of the impeller being affected.
 3.2 When handling the equipment, care should be taken with corners and edges and that the weight distribution within the unit is considered. Lifting gear such as slings or ropes must be arranged so as not to bear on the casing.
 3.3 Equipment stored on site prior to installation should be protected from the weather and steps taken to prevent ingress of contaminants.

4.0 OPERATIONAL LIMITS

- 4.1 It is important that the specified operational limits for the equipment are adhered to e.g. operational air temperature, air borne contaminants and unit orientation.
 4.2 Where installation accessories are supplied with the specified equipment eg. wall mounting brackets. They are to be used to support the equipment only. Other system components must have separate provision for support.
 4.3 Flanges and connection spigots are provided for the purpose of joining to duct work systems. They must not be used to support the ductwork.

5.0 INSTALLATION REQUIREMENTS

In addition to the particular requirements given for the individual product, the following general requirements should be noted.

- 5.1 Where access to any part of equipment which moves, or can become electrically live are not prevented by the equipment panels or by fixed installation detail (eg ducting), then guarding to the appropriate standard must be fitted.
 5.2 The electrical installation of the equipment must comply with the requirements of the relevant local electrical safety regulations.
 5.3 For EMC all control and sensor cables should not be placed within 50mm or on the same metal cable tray as 230V switched live, lighting or power cables and any cables not intended for use with this product.

6.0 COMMISSIONING REQUIREMENTS

- 6.1 General pre-commissioning checks relevant to safe operation consist of the following:
 Ensure that no foreign bodies are present within the fan or casing.
 Check electrical safety. e.g. Insulation and earthing.
 Check guarding of system.
 Check operation of Isolators/Controls.
 Check fastenings for security.
 6.2 Other commissioning requirements are given in the relevant product documentation.

7.0 OPERATIONAL REQUIREMENTS

- 7.1 Equipment access panels must be in place at all times during operation of the unit, and must be secured with the original fastenings.
 7.2 If failure of the equipment occurs or is suspected then it should be taken out of service until a competent person can effect repair or examination. (Note that certain ranges of equipment are designed to detect and compensate for fan failure).

8.0 MAINTENANCE REQUIREMENTS

- 8.1 Specific maintenance requirements are given in the relevant product documentation.
 8.2 It is important that the correct tools are used for the various tasks required.
 8.3 If the access panels are to be removed for any reason the electrical supply to the unit must be isolated.
 8.4 A minimum period of two minutes should be allowed after electrical disconnection before access panels are removed. This will allow the impeller to come to rest.
NB: Care should still be taken however since airflow generated at some other point in the system can cause the impeller to "windmill" even when power is not present.
 8.5 Care should be taken when removing and storing access panels in windy conditions.

Technical or commercial considerations may, from time to time, make it necessary to alter the design, performance and dimensions of equipment and the right is reserved to make such changes without prior notice.

Notes



Western Industrial Estate
Caerphilly United Kingdom
CF83 INA
T: 029 2088 5911
F: 029 2088 7033
E: info@nuaire.co.uk
W: www.nuaire.co.uk