

NUAIRE

Mark Ten

Direct Drive Roof Extract Units

Installation and Maintenance

NUAIRE

NuAire Limited
 Western Industrial Estate, Caerphilly,
 Mid Glamorgan CF83 1XH
 Telephone: 02920 885911
 Facsimile: 02920 887033
 Email: info@nuaire.co.uk
 www.nuaire.co.uk

Leaflet 670092

OCTOBER 2001

Mark Ten fan
 Note that shutters axis
 must run 'up & down'
 the roof slope as shown

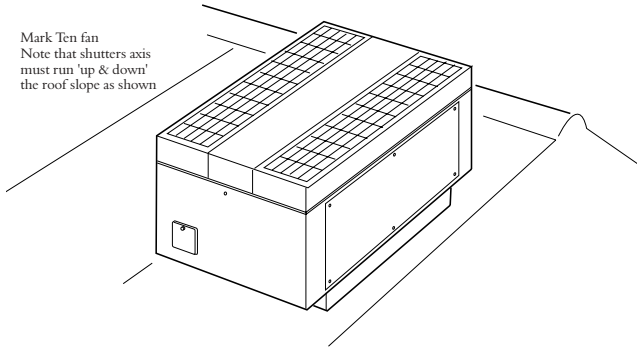

Fig.1a General view of a typical unit.

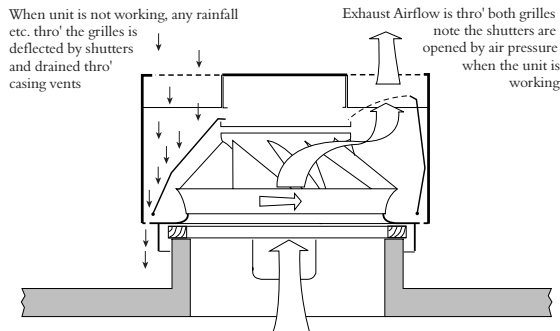

Fig.1b Section view of a unit.

Introduction

The Mark Ten Direct Drive unit housing is a monocoque manufactured in aluminium alloy. The impeller and shutters are also aluminium. A service panel is provided on larger units for inspection purposes and easy access to the internal parts.

The unit incorporates a single inlet high performance mixed flow impeller with asymmetrical blade spacing, dynamically balanced and directly driven by the motor.

The motor has sealed for life bearings and is manufactured to BS5000. Rotating parts are isolated from the unit case by resilient mountings. Units 1000 & 1250 have provision for the fitting of an optional special hoist to facilitate removal and replacement of the motor from below.

Mounting Note, Pitched Roofs:

Units can be installed up to an angle of 80° from the horizontal except for units 1000 and 1250 when the angle must not be more than 10°. Units must be mounted with the longer case dimension running up and down the roof slope (fig1a) to ensure satisfactory shutter operation.

ISOLATION

Note that the unit must be provided with a means of isolation (by others) for maintenance purposes etc. A suitable isolator can be supplied by NuAire on request as a separate item.

Contents	Page
Introduction	1
Coding	1
Handling	1
Dimensions	2
Installation	3
Curb details	3
Converters	4
Connection to supply	5
Electrical information	6
Speed Controls	6
Electrical diagrams	7
Maintenance	8
Removing motors/impellers	9
Certification	10

Coding explained

630 MTD 1 /2

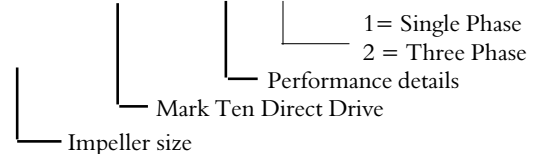

Handling

Care must be taken at all times when handling the unit. A protective covering has been fitted prior to despatch to avoid damage in transport and storage. Do not remove this until the unit is ready to be installed.

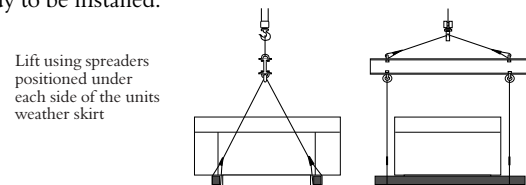

Larger units which cannot be carried must be lifted on spreaders positioned on each side of the weather skirt. Ensure the unit is evenly balanced on the spreaders before lifting and that any slings or webbing etc being used do not come into contact with the casing. **CAUTION. Units must not be stacked.**

Transit bolts (sizes 1000 & 1250)

To prevent unnecessary strain during transit, transit bolts have been fitted to the unit prior to despatch. These bolts are painted red and are located one under each end under the unit, outside the weather skirt. Only remove these bolts when the unit has been secured to the roof curb.

Under no circumstances test or run the unit until the transit bolts have been removed

Dimensions

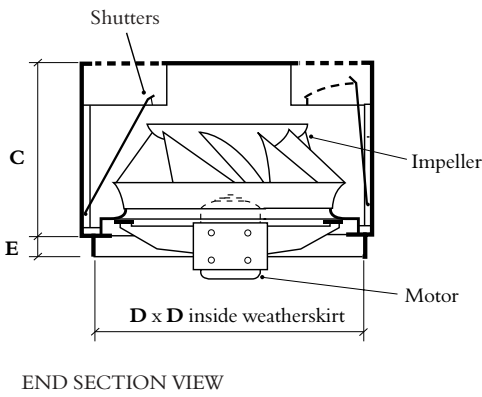
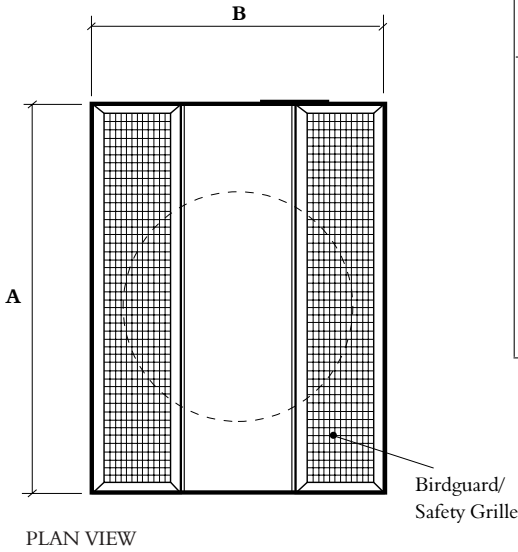
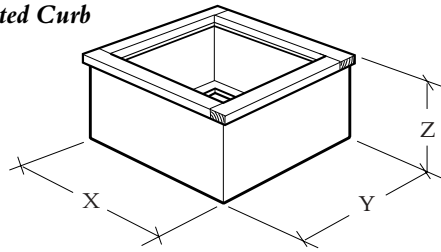

Table of dimensions & weights

Unit size	A	B	C	D	E	Weight kg excl. motor
160/224 MTD	362	292	149	265	50	4*
280/315 MTD	499	419	210	390	50	8*
400 MTD	647	549	320	490	50	10
500 MTD	749	649	397	590	50	19
630 MTD	853	756	498	690	75	29
800 MTD	1150	1038	593	790	75	48
1000 MTD	1402	1102	731	1040	75	80
1250 MTD	1800	1500	926	1240	75	160

Fig 3 Prefabricated Curb



* This weight includes motor

Prefab Curb dimensions

Unit size	P.F. Curb	X	Y	Z
280 MTD	280 PFC/1	350	350	238
400 MTD	400 PFC/1	450	450	238
500 MTD	500 PFC/1	550	550	238
630 MTD	630 PFC/1	650	650	250
800 MTD	800 PFC/1	750	750	250
1000 MTD	1000 PFC/1	1000	1000	250
1250 MTD	1250 PFC/1	1200	1200	250

Table of Curb Dimensions

Unit size	A	B	C	D
160/224 MTD	125	50	175	225
280/315 MTD	250	50	300	350
400 MTD	300	75	375	480
500 MTD	400	75	475	580
630 MTD	500	75	575	680
800 MTD	600	75	675	780
1000 MTD	800	100	900	1030
1250 MTD	1000	100	1100	1230

Fig 4 Curb Dimensions

Concrete Roof

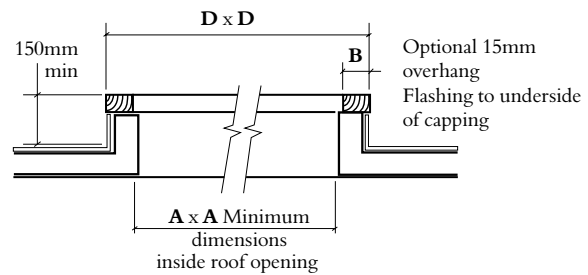

Profile Roof

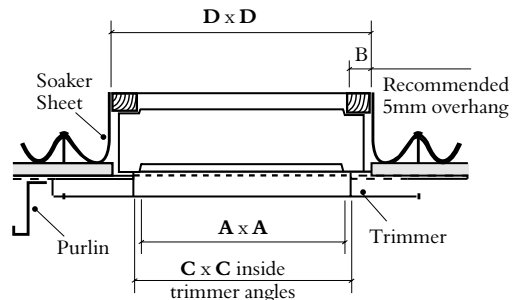

Note: All wooden curbs and caps to be hardwood or treated softwood of minimum 50mm thickness. (supplied and fitted by others)

Installation

Mounting on Pitched Roof:

Units can be installed up to an angle of 80° from the horizontal except for units 1000 and 1250 when the angle must not be more than 10°. Units must be mounted with the longer case dimension running up and down the roof slope to ensure satisfactory shutter operation.

Prefabricated Curb

Prefabricated Curbs are available matched to each unit. The curbs are manufactured in aluminium alloy with treated timber cappings. When installed the curb must be securely bolted to the trimmer angles.

The timber capping is adjustable and is set at the maximum overhang of 15mm. With the capping set at this position the roof flashing can be run up the sides of the curb finishing neatly beneath the timber overhang. This will ensure that when installed the unit base is a close fit on the curb and cannot be distorted by over-tightening the fixing screws. Alternatively the flashing can be run over the capping. Slacken the capping fasteners and, depending on the thickness of the flashing, relocate the capping in the

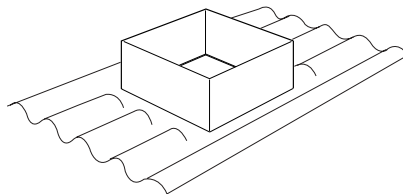

Fig 5 Soaker Sheet

appropriate position to ensure a close fit inside the units weather skirt when installed on the curb. Re-tighten the fasteners.

Soaker Sheet

Soaker Sheets are available manufactured in GRP. Each sheet is 1950mm long and can be supplied to match most roof profiles. The Soaker Sheet is placed over the Prefabricated Curb, trimmed to height and built into the roof in accordance with standard building practice.

When installing a Soaker Sheet over a NuAire Prefabricated Curb the timber capping overhang must be reduced from 15mm to 5mm. Do this by slackening the timber capping fasteners and moving the timber capping inwards as required. Re-tighten the fasteners.

Fixing

The Mark Ten unit must be fitted securely to its curb /upstand to prevent vibration and wind damage. Two fixing holes are provided on each side of the units weather skirt.

This allows the unit to be fixed directly to the timber capping on top of the curb. Both wood screws and bolts are recommended as suitable fixings provided they are non-corrodible.

NOTE:

ENSURE RED TRANSIT BOLTS (IF FITTED) ARE REMOVED FROM THE FAN BASE DURING INSTALLATION.

Quiet Curbs (Attenuators)

NuAire Quiet curbs are a range of attenuators designed for use with the Mark Ten units. Each attenuator fits the same size curb as supports the extract unit without need to alter any builders work.

CAUTION

Under no circumstances must the Quiet Curb be lifted by slings or ropes passed through the attenuators airways.

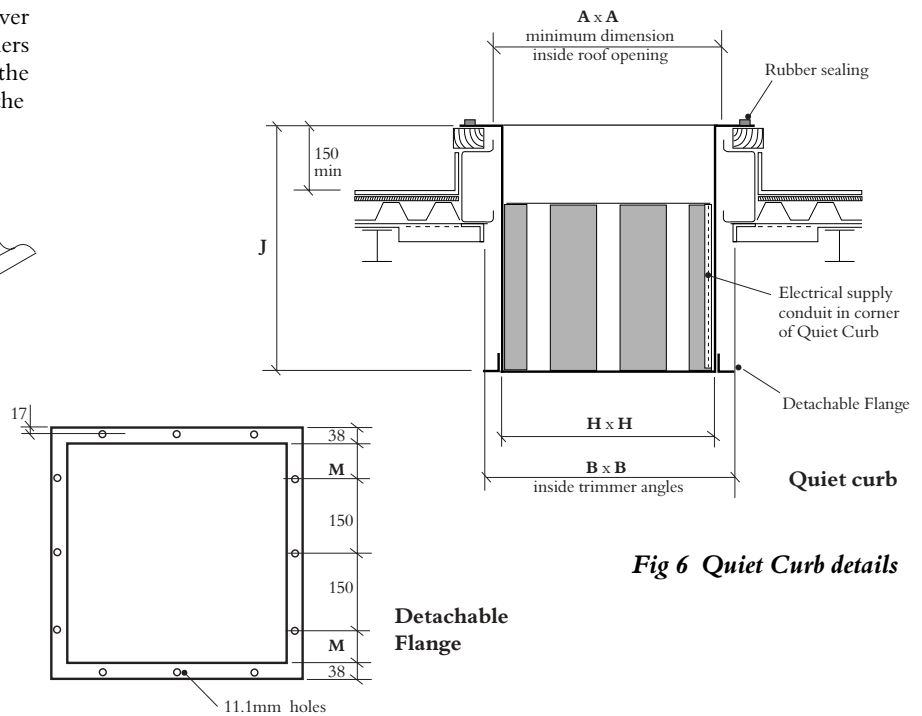

Fig 6 Quiet Curb details

Table of dimensions (quiet curb).

Mark Ten size code	A	B	Quiet Curb SHORT			Weight kg	Quiet Curb LONG			Weight kg	Detachable Flange	
			code	H	J		code	H	J		M	No. holes
280/315	250	300	QC28S	230	500	8.3	QC28L	230	950	12.3	51	8
400	300	375	QC40S	280	600	10.5	QC40L	280	1050	14.0	66	8
500	400	475	QC50S	380	670	30	QC50L	380	1120	40	41	12
630	500	575	QC63S	480	825	46	QC63L	480	1275	74	16	16
800	600	675	QC80S	580	720	53	QC80L	580	1170	85	68	16
1000	800	900	QC100S	780	720	66	QC100L	780	1170	104	17	24
1250	1000	1100	QC125S	980	720	118	QC125L	980	1170	198	42	28
-	1200	1300	QC140S	1180	800	170	QC140L	1180	1250	281	68	32

Installation and Maintenance MARK TEN DD ROOF EXTRACT

Installation (continued)

Quiet Curb Extension Sections

Two or more modules can be joined together to increase the attenuation. These extensions are available in two lengths, 450 and 900mm long. They are complete with flanges to facilitate straight forward connection of ductwork.

Converters

The NuAire Mark Ten unit can be fitted on a larger size Quiet Curb if desired by using a converter. This arrangement produces a similar attenuation but at a lower aerodynamic resistance than would be obtained from a standard sized Quiet Curb.

To install, place the converter over the curb and firmly secure to the timber capping with non corrodible wood screws through the holes provided in the weather skirt

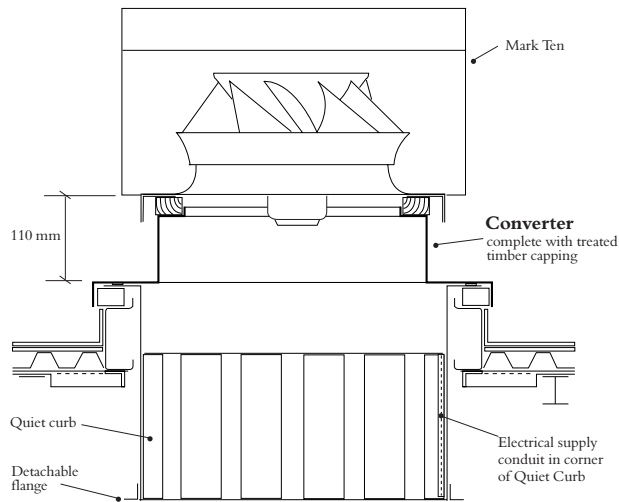

Fig 7 Converter installation

Mark Ten Code	Converter Model	Quiet Curb
400MTD	CA	QC63
500MTD	CB	QC63
630MTD	CC	QC100
800MTD	CD	QC100
1000MTD	CE	QC125
1250MTD	CG	QC140

Connecting the electrical supply

Units up to and including size 315

To simplify connection the routing of electrical cables to the smaller Mark Ten units, NuAire supply as an optional extra, a weatherproof junction box and a short length of flexible conduit to link between the units upstand and a matching conduit adaptor beneath the overhang on the Mark Ten (see fig. 8).

When fitting the junction box, sufficient clearance should be given to prevent the Mark Ten's weather skirt from fouling the junction box after it has been 'weathered in' to the side of the upstand. The wiring may then be routed to the unit from the ductwork via the junction box and conduit.

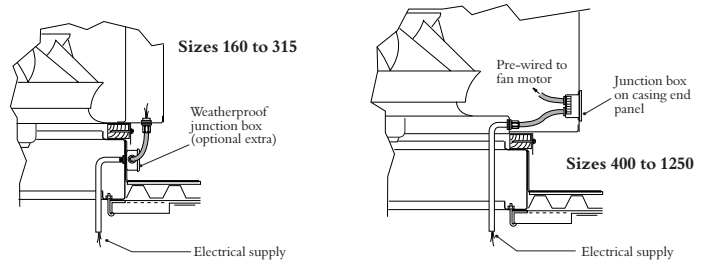

Fig 8 Connecting the supply

Units size 400 to 1250

The electrical supply enters the Mark Ten via the ductwork / curb opening through a 20mm conduit adaptor in the baseplate of the unit and a flexible conduit terminating in the junction box located behind a small access panel on the end of the casing.

Quiet Curb

When using a Mark Ten in conjunction with a Quiet Curb, a conduit is set in one corner of the attenuator to facilitate easy routing of the electrical supply from ductwork to the fan.

Isolators

The unit must be fitted with a means of isolation for maintenance purposes etc. Isolators are not supplied as standard with the Mark Ten range.

Isolator to be supplied by others. An isolator is available as an optional extra if required from NuAire.

Switching Details

Check that voltage on the motor rating plate is suitable for your supply.

For single phase motors, the switching mechanism should be rated at not less than three times the full load motor current.

For three phase motors, the switching mechanism should be rated in accordance with the test certificate issued with the unit.

Single phase and three phase direct on line start units are supplied pre-wired from the motor to a junction box located behind a small access panel on the end of the casing. Size 160/224 should be provided with a two pole isolator. All others require a three pole isolator.

Two speed three phase motors and motors rated at 4kw and above require a six pole isolator to provide for 'High Low' speed running and star/delta starting.

Fan Rotation



Looking from above, the fan rotates in an anti-clockwise direction. This is indicated by an arrow on the chassis.

Single phase motors are despatched pre-wired from the factory to give the correct rotation.

Units with three phase motors should be given a trial run. If the impeller revolves in the wrong direction, interchange any two of the supply phases to reverse rotation.

Installation (continued)

Electrical information

Because start (sc) and run (flc) currents depend on the duty of the individual unit and its associated system, the quoted values in the table are nominal. The values stated on the test certificate issued with each unit are those obtained during workshop testing. Start currents are peak instantaneous values and are for DOL starting unless otherwise indicated.

Start and Run currents quoted are for a 230v 1 phase 50Hz or a 400v 3 phase 50Hz a.c. supply.

Overloads

All overloads must be set to the maximum full load current of the equipment they are protecting. The recommended overload setting will be found on the test certificate issued with the unit.

Single Phase Speed Controls

Single phase speed controls provide on / off switching, mains indication and speed regulation for the Mark Ten direct drive extract units listed in the table.

Speed is adjusted in defined steps through a multi position switch and a tapped auto transformer. This form of control is radio interference free, complying with BS800. On / Off switches are two pole and incorporate neon mains indicators.

The associated extract unit may not always start from the lowest control setting, though there is no danger of overheating. It is therefore recommended that the unit is started at one of the higher speeds, then regulated to the required speed.

Controls coded SPCON1 to SPCON3 are 3 step; SPCON4 to SPCON6 are 5 step.

Fixing Single Phase Speed Controls

Controls can be mounted on any flat firm surface, in any attitude, through fixing holes provided in the control's base. These holes are easily accessed when the cover is removed. Drill and plug the mounting surface as necessary, positioning the control cover so that the cover retaining screws will remain accessible. This is particularly important if a battery of controls is being fitted. Fix with No 8 woodscrews or equivalent.

For wiring purposes, covers are provided with knockouts for cable entry, up to 20mm conduit on units 2, 3, 4, 5 & 6. Bases of controls 1, 2, 3 & 4 have 20mm holes for cable whilst units 5 & 6 are pierced to accommodate a 20mm series conduit box (not supplied).

Motor Electrical Information & Weight

kW	Poles	Nominal Speed		flc amps	sc amps	Weight kg
		r/s	rpm			
0.010	4	22	1296	0.37	0.48	-
0.015	4	24	1410	0.33	0.36	2.10
0.040	2	48	2800	0.20	0.32	-
0.049	4	22	1284	0.47	0.78	2.30
0.150	4	24	1440	1.10	1.88	3.20
0.180	6	16	960	1.50	3.00	6.50
0.370	4	24	1440	2.50	7.10	6.50
0.500	4	24	1416	3.4	8.5	10.00
0.180	4	24	1464	0.85	2.00	4.50
0.180	6	16	990	0.70	1.90	5.50
0.230	8	12	720	1.10	2.30	9.50
0.370	4	24	1440	1.10	4.40	6.50
0.550	4	24	1416	1.60	6.40	9.00
0.550	6	16	954	1.60	5.40	9.50
0.750	8	12	720	2.50	8.80	20.00
0.750	10	9.3	558	3.80	10.85	30.00
0.750	12	8	480	4.00	8.40	40.00
0.80*	12	8	462	3.10	7.40	-
1.50	4	24	1448	4.140	17.00	16.00
1.50	6	16	966	4.10	15.20	32.50
1.90	12	8	480	7.20	20.90	80.00
2.20	8	12	720	6.00	25.00	52.00
4.0	6	16	960	9.30	47.00	54.00
7.5	8	12.3	738	16	48**	115.00

* Three phase speed control available

** Star Delta starting

Single Phase Speed Control selection

Fan code	SPCON 1	SPCON 2	SPCON 3	SPCON 4	SPCON 5	SPCON 6
	plastic cased			metal cased		
224 MTD1	x	-	x	x	-	-
280 MTD2	x	-	x	x	-	-
315 MTD1	-	-	-	x	-	-
400 MTD3	x	-	x	x	-	-
400 MTD12	x	-	x	x	-	-
500 MTD1	-	-	-	-	x	-
500 MTD9	-	-	-	-	-	x

Single Phase Speed Control dimensions

Control code	A	B	C
SPCON 1	315	140	75
SPCON 2	315	140	75
SPCON 3	315	140	75
SPCON 4	315	140	75
SPCON 5	315	185	105
SPCON 6	315	185	105

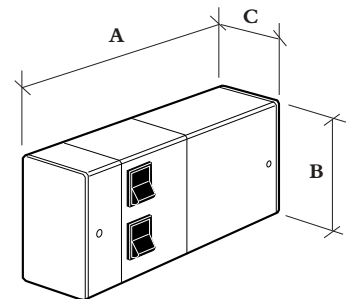

Fig 9 Auto transformer Speed Control

Installation and Maintenance MARK TEN DD ROOF EXTRACT

Three Phase Speed Control

A number of three phase units are available for speed control which provides on / off switching and speed regulation in five defined steps through a rotary switch and auto transformer.

This form of control is radio interference free, complying with BS800. On / Off switches are two pole and incorporate neon mains indicators.

The associated extract unit may not always start from the lowest control setting, though there is no danger of overheating. It is therefore recommended that the unit is started at one of the higher speeds, then regulated to the required speed.

On no account connect a NEUTRAL to the motor as this will cause overheating of the motor during speed regulation.

Three Phase Two Speed Option

Where speed control for a three phase Mark Ten belt drive is required, NuAire offer two speed two speed motors because of the low energy losses inherent in the two speed motor arrangement.

Two speed motors may be of the pole change type or the P.A.M. (pole amplitude modulated) type depending on the ratio of the two speeds required.

In general, pole change motors are used to achieve speed ratios of 2:1 and P.A.M. motors to achieve closer or wider ratios.

Typical motor speed ratios obtainable are:

4 pole/6 pole	6p/8p	8p/10p	10p/12p
4p/8p	6p/10p	8p/12p	
	6p/12p		

Control circuitry for both types is identical and the NuAire two speed control switch, incorporating starting contactors, speed selector, thermal overloads and single phasing protection is recommended for all two speed applications(see fig. 8).

Three Phase Speed Control dimensions

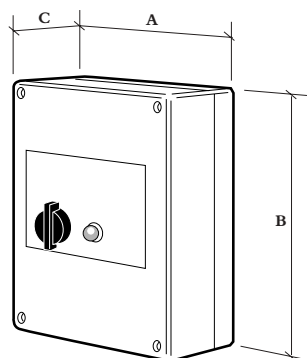

Fig 10 Auto transformer Speed Control

Control code	A	B	C
3SPCON 1	188	253	110
3SPCON 2	188	253	110

Fixing

Controls can be mounted on any flat firm surface, in any attitude, through fixing holes provided in the control's base. These holes are easily accessed when the cover is removed. Drill and plug the mounting surface as necessary. Fix with No 8 wood-screws or equivalent.

For wiring purposes, bases are provided with knockouts for cable entry, up to 20mm conduit (not supplied).

Three Phase Speed Control selection

Fan code	3SPCON 1	3SPCON 2
160 MTD 1	-	-
224 MTD 1	-	-
280 MTD 2	-	-
315 MTD 1	-	-
400 MTD 3	x	-
400 MTD 9	x	-
400 MTD 12	-	-
500 MTD 1	-	-
500 MTD 6	-	x
500 MTD 9	x	-
500 MTD 12	x	-
630 MTD 12	x	-
1000 MTD 12	-	x

Service

As a manufacturer NuAire provides you with factory trained Service Engineers. Our Engineers are supported by a comprehensive range of spare parts available off the shelf.

If you are an industrial or commercial user, you may be interested in details of NuAire's regular maintenance and Service Contracts. This is a worthwhile service that helps you get the most from our products.

Our Service Department will be happy to give you more information.

Please telephone: **02920 858585**

3 YEAR WARRANTY

The three year warranty starts from the date of delivery and includes parts and labour for the first year.

The labour element is subject to full, free and safe access to the equipment as recommended by the CDM regulations.

The remaining two years covers replacement parts only.

NOTE:

Installation & Maintenance of the equipment must be as directed in the instructions provided with the unit.

Controls Application Service (CAS)

A team of Engineers and technicians is available to provide pre and post order support.

We are on hand to provide help and advice from the most basic use of any NuAire equipment to the more complex applications, maximising on the versatility of our SMART and NetLink control products.

Telephone: **02920 858585**

Facsimile: **02920 858586**

MARK TEN DIRECT DRIVE WIRING DIAGRAMS

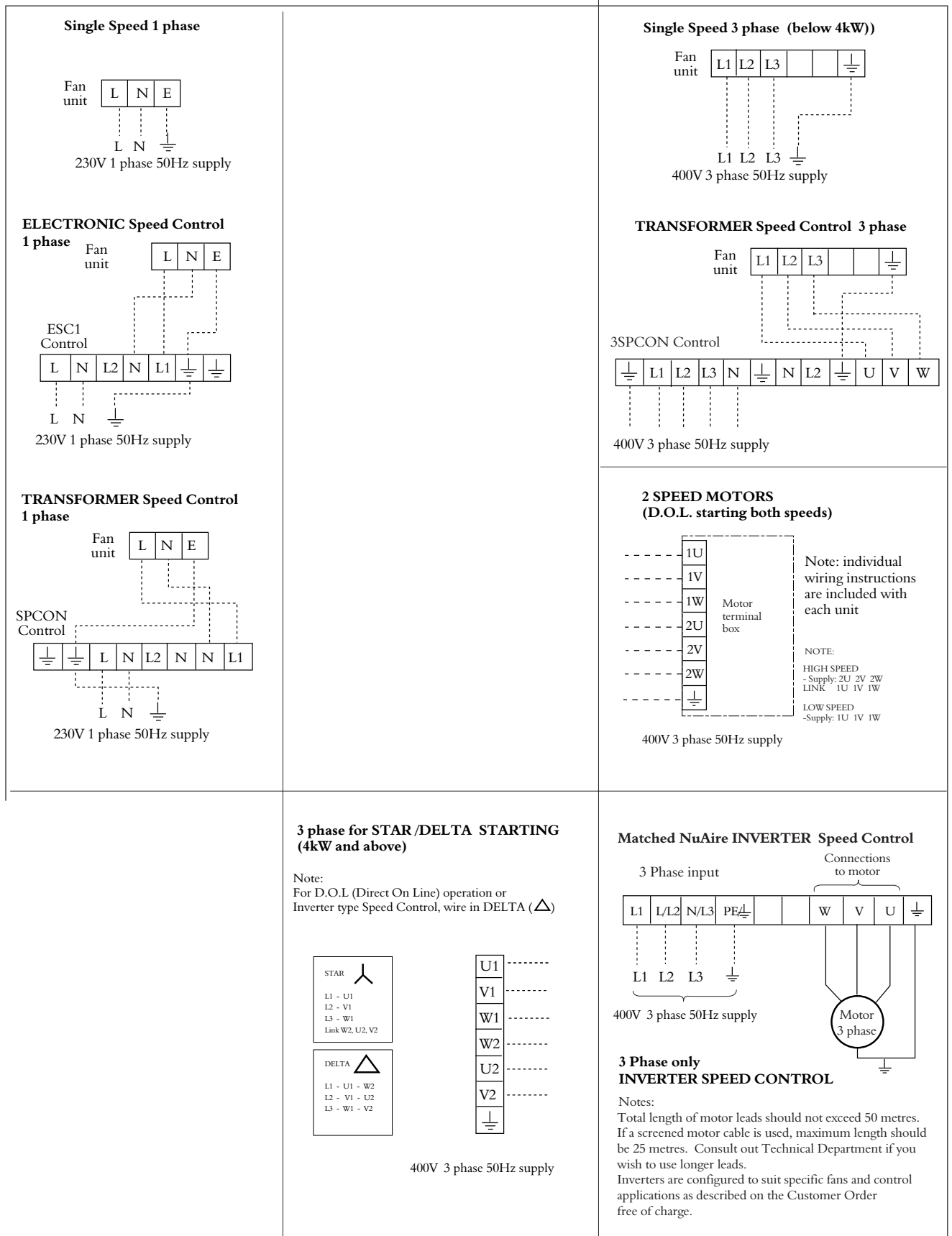

Maintenance

ISOLATION

Note that the unit must be provided with a means of isolation (by others) for maintenance purposes etc. A suitable isolator can be supplied by NuAire on request as a separate item.

WARNING:

BEFORE COMMENCING WORK MAKE SURE THAT THE UNIT AND NUAIRE CONTROL, IF FITTED, ARE ELECTRICALLY ISOLATED FROM THE MAINS SUPPLY. ALWAYS ELECTRICALLY ISOLATE THE UNIT BEFORE REMOVING ANY PANELS

Routine Maintenance

It is essential that maintenance on the Mark Ten Direct Drive unit is carried out on a regular basis.

1. First inspection three months after the unit has been commissioned.
2. Thereafter once every twelve months.

Points to check

- i) Check that the birdguard / safety grilles are free of obstruction.
- ii) Check that the movement of both shutters is full and free.
- iii) Check that the impeller is clean and does not foul the casing.
- iv) Give the unit a good visual check for any loose bolts, fasteners, worn anti vibration mountings or anything else that might impair the Mark Ten units efficiency.

Access

On all units the top cover / outlet grille assembly is a single unit secured to the top of the casing by four screws set in keyhole slots. To remove, slacken the four screws located on the lip inside the safety grille a couple of turns, slide the cover sideways and lift off (fig. 11).

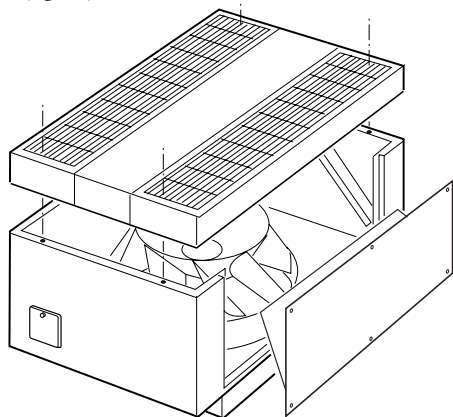

Fig 11 Removing covers

Side Panel Removal

On units size 630 and above, the side panel and shutter assembly is easily removed by releasing the captive screws around the edge of the panel and lifting it out (fig. 11).

On units size 500 and below, the side panel and shutter assembly is part of the case.

Lubrication

Standard motors are fitted with sealed for life bearings and do not require any lubrication. In the unlikely event of a unit being supplied with a motor that requires lubrication, all grease points will have been tubed back to a central grease nipple located on the base tray of the unit. These motors must be lubricated in accordance with the individual makers requirements.

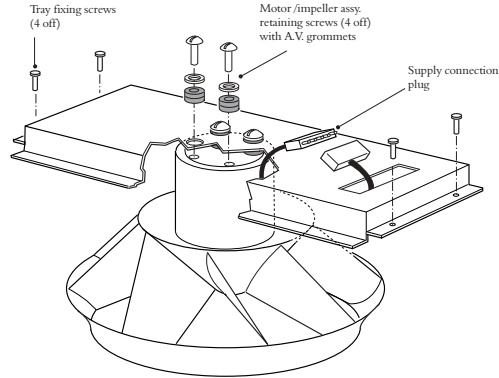

Fig 12 Size 160 to 315 sub assembly

Impeller and Motor Bridge Assembly

Sizes 160 to 315

On these smaller units the motor and impeller are suspended from a bridge. The entire assembly can be removed by releasing the four captive screws, two each side of the bridge, and unplugging the motor supply (fig 12).

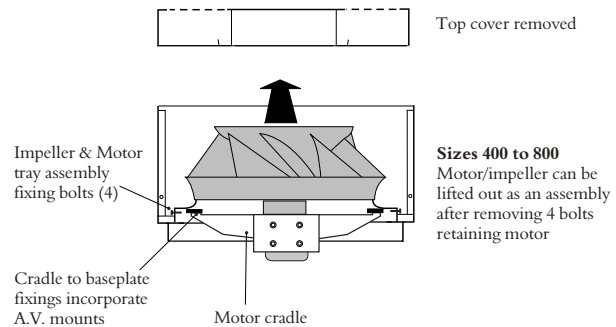

Fig 13 Size 160 to 315 sub assembly

Impeller and Motor Assembly

Sizes 400 to 800

The motor and impeller assembly can be lifted out of the housing as a complete unit. The motor is mounted into a square frame with four arms supported on AV's beneath the venturi tray. Disconnect the electrical supply, unclip the flexible conduit to the motor and loosen the four bolts, two each side of the tray, then lift the complete assembly out (Fig. 13).

Impeller and Motor Assembly

Sizes 1000 and 1250

On these two larger sized units an integral steel chassis supports the motor and impeller. First remove the impeller as described in 'Impeller size 400 and above', disconnect the electrical supply to the motor and taking care to support the motor, remove the motor mounting bolts. The motor can now be lifted free from the unit. To assist removal of larger motors a special hoist can be supplied which locates onto the chassis and allows the motor, when unbolted, to be lowered to the floor below.

Installation and Maintenance MARK TEN DD ROOF EXTRACT

Fig 14 Size 1000 to 1250

Sizes 1000 to 1250
Using special service hoist (optional) motor can be lowered out of the unit after releasing the impeller and removing the 4 bolts retaining motor

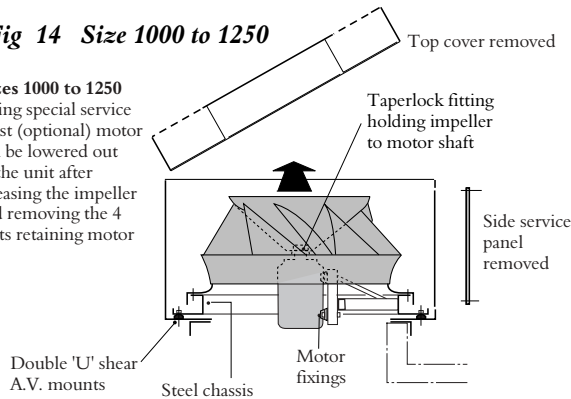

Note

before removing the impeller from the motor shaft, please note or mark the position of the impeller in relation to the shaft so that it can be re-assembled in the same position.

Impeller sizes 160 to 315

The impeller on the 160 size unit is integral with the motor and should not be removed.

On size 224, 280 and 315 size units the impeller is secured by two grub screws acting directly on the motor shaft. By loosening these two screws the impeller can be removed (see fig 15).

Impeller sizes 400 to 1250

The impeller is secured to the motor shaft by means of a taperlock. To release, remove the two grub screws each side of the split. Oil the thread of one grub screw and replace it in the hole opposite the split. When it is tightened the grub screw will force apart the taperlock allowing it to be removed from the shaft along with the impeller (Fig.15).

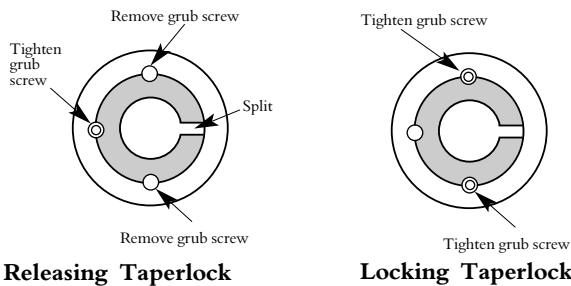

Releasing Taperlock

Locking Taperlock

Fig 15 Taperlock fitting

Anti-Vibration Mountings

Units 160 to 315

The motor is isolated mechanically from the bridge by grommet type anti-vibration mountings through which the motor mounting bolts pass (fig12).

Units 400 to 800

The motor is rigidly bolted to a frame with four arms. The end of each arm locates under a steel cover isolated by a pocket type anti-vibration mounting. By releasing the bolts on each side of the steel cover a worn AV can be replaced without dismantling the unit (fig 13).

Units 1000 and 1250

The motor frame and tray assembly is supported by anti-vibration mountings of the double U shear type. The exact number is determined by the size and speed of the motor. All AVM's are located around the edge of the tray assembly, bolted through to the base of the unit (fig 14).

Impeller Maintenance

The impeller itself needs no special maintenance apart from cleaning. Any build up of dust or grease etc. can be best removed with hot soapy water. On no account must the unit come into contact with caustic fluids.

Replacing the impeller

To achieve optimum performance when re assembled, the impeller should overhang the inlet venturi by the following dimensions

Unit size	A
160	4
224	4
280	4
315	5
400	6
500	8
630	10
800	12
1000	15
1250	20

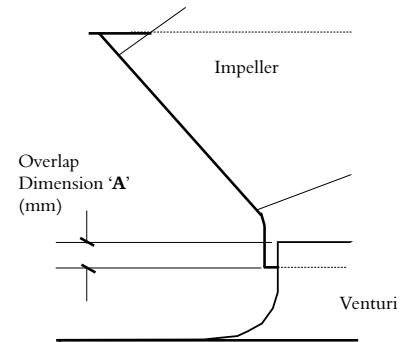

Fig 16 Impeller overhang setting

Size 160 to 315

Impellers are secured to the motor shaft by two grub screws, To adjust simply slacken, relocate the impeller to achieve the correct overhang and re-tighten.

Size 400 to 1250

Impellers are secured directly to the motor shaft by two taperlock fitting.

- i) Clean all grease and protective coating from the taperlock, impeller boss and the area of shaft where the impeller will be fitted.
- ii) Place the impeller over the motor shaft and locate the taperlock into the impeller boss. Insert two grub screws, one each side of the split.
- iii) Align the impeller on the motor shaft to the correct overhang and tighten.

Special Instructions for Treated Motors used in Chlorinated atmospheres

Sealed motors require no special treatment.

Ventilated motors which operate in chlorinated atmospheres are vacuum impregnated with a special corrosion inhibitor which ensures that all the hidden parts of the motor and bearings are fully protected. Once the treatment is carried out, full protection can be maintained by regular application once every 12 months of WD40, a corrosion inhibitor readily available in aerosols from most garages.

To apply WD40, first remove the impeller, then direct the spray into the motor cooling vents whilst the motor is running so that the spray is drawn into the motor casing.



Ordering Spare Parts

When ordering spare parts, please quote the serial number of the unit and a full description of the part required.

*We declare that the machine named below
conforms to the requirements of EC Council Directives
relating to Electromagnetic Compatibility and
Safety of Electrical Equipment.*

Designation of machinery :-	ROOF EXTRACT FAN
Machinery Types :-	MARK TEN DIRECT DRIVE (MTD)
Relevant EC Council Directives :-	89/336/EEC, 92/31/EEC (EMC) 73/23/EEC, 93/68/EEC (Low Voltage Directive)
Applied Harmonised Standards :-	E50081-1, EN50082-1, EN60204-1 EN60335-2-80
Basis of Self Attestation :-	Quality Assurance to BS EN ISO 9001 BSI Registered Firm Certificate No. FM 149

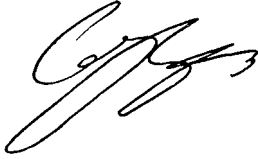
Signature of manufacture representatives :-

	Name:	Position:	Date:
1)	 C. Biggs	Technical Director	3. 3. 00
2)	 W. Glover	Manufacturing Director	3. 3. 00

DECLARATION OF INCORPORATION & INFORMATION FOR SAFE INSTALLATION, OPERATION & MAINTENANCE

MARCH 2000

We declare that the machinery named below is intended to be assembled with other components to constitute a system of machinery.

The machinery shall not be put into service until the system has been declared to be in conformity with the provisions of the EC Council Machinery Directive.

Designation of machinery :- ROOF EXTRACT FAN



Machinery Types :- MARK TEN DIRECT DRIVE (MTD)

Relevant EC Council Directives :- 98/37/EC (Machinery Directive)

Applied Harmonised Standards :- EN292-1, EN292-2, EN294, EN29001

Applied National Standards :- BS848 Parts One, Two and Five

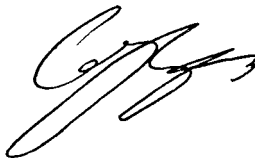
Signature of manufacture representatives :-

	Name:	Position:	Date:
1)	 C. Biggs	Technical Director	3.3.00
2)	 W. Glover	Manufacturing Director	3.3.00

INFORMATION FOR SAFE INSTALLATION, OPERATION AND MAINTENANCE OF NUAIRE VENTILATION EQUIPMENT

To comply with EC Council Directives 98/37/EC Machinery Directive

To be read in conjunction with the relevant Product Documentation (see 2.1)

1.0 GENERAL

- 1.1 The equipment referred to in this **Declaration of Incorporation** is supplied by NuAire to be assembled into a ventilation system which may or may not include additional components.
The entire system must be considered for safety purposes and it is the responsibility of the installer to ensure that all of the equipment is installed in compliance with the manufacturers recommendations and with due regard to current legislation and codes of practice.

2.0 INFORMATION SUPPLIED WITH THE EQUIPMENT

- 2.1 Each item of equipment is supplied with a set of documentation which provides the information required for the safe installation and maintenance of the equipment. This may be in the form of a Data sheet and/or Installation and Maintenance instruction.
- 2.2 Each unit has a rating plate attached to its outer casing. The rating plate provides essential data relating to the equipment such as serial number, unit code and electrical data. Any further data that may be required will be found in the documentation. If any item is unclear or more information is required, please contact NuAire.
- 2.3 Where warning labels or notices are attached to the unit the instructions given must be adhered to.

3.0 TRANSPORTATION, HANDLING AND STORAGE

- 3.1 Care must be taken at all times to prevent damage to the equipment. Note in particular that shock to the unit may result in the balance of the impeller being affected.
- 3.2 When handling the equipment, care should be taken with corners and edges and that the weight distribution within the unit is considered. Lifting gear such as slings or ropes must be arranged so as not to bear on the casing.
- 3.3 Equipment stored on site prior to installation should be protected from the weather and steps taken to prevent ingress of contaminants.

4.0 OPERATIONAL LIMITS

- 4.1 It is important that the specified operational limits for the equipment are adhered to *e.g. operational air temperature, air borne contaminants and unit orientation.*
- 4.2 Where installation accessories are supplied with the specified equipment eg. wall mounting brackets. They are to be used to support the equipment only. Other system components must have separate provision for support.
- 4.3 Flanges and connection spigots are provided for the purpose of joining to ductwork systems. They must not be used to support the ductwork.

5.0 INSTALLATION REQUIREMENTS

- In addition to the particular requirements given for the individual product, the following general requirements should be noted.*
- 5.1 Where access to any part of equipment which **moves**, or can become **electrically live** are not prevented by the equipment panels or by fixed installation detail (eg ducting), then guarding to the appropriate standard must be fitted.
- 5.2 The electrical installation of the equipment must comply with the requirements of the relevant local electrical safety regulations.

6.0 COMMISSIONING REQUIREMENTS

- 6.1 General pre-commissioning checks relevant to safe operation consist of the following -
Ensure that no foreign bodies are present within the fan or casing
Check electrical safety. *e.g. Insulation and earthing.*
Check guarding of system.
Check operation of Isolators/Controls.
Check fastenings for security.
- 6.2 Other commissioning requirements are given in the relevant product documentation.

7.0 OPERATIONAL REQUIREMENTS

- 7.1 Equipment access panels must be in place at all times during operation of the unit, and must be secured with the original fastenings.
- 7.2 If failure of the equipment occurs or is suspected then it should be taken out of service until a competent person can effect repair or examination. (Note that certain ranges of equipment are designed to detect and compensate for fan failure).

8.0 MAINTENANCE REQUIREMENTS

- 8.1 Specific maintenance requirements are given in the relevant product documentation.
- 8.2 It is important that the correct tools are used for the various tasks required.
- 8.3 If the access panels are to be removed for any reason the electrical supply to the unit must be isolated.
- 8.4 A minimum period of two minutes should be allowed after electrical disconnection before access panels are removed. This will allow the impeller to come to rest.
NB: Care should still be taken however since airflow generated at some other point in the system can cause the impeller to "windmill" even when power is not present.
- 8.5 Care should be taken when removing and storing access panels in windy conditions.